

Model 9400 Installation Instructions

www.LCDarms.com | 800.524.2744

1a

8384 Countertop Mount

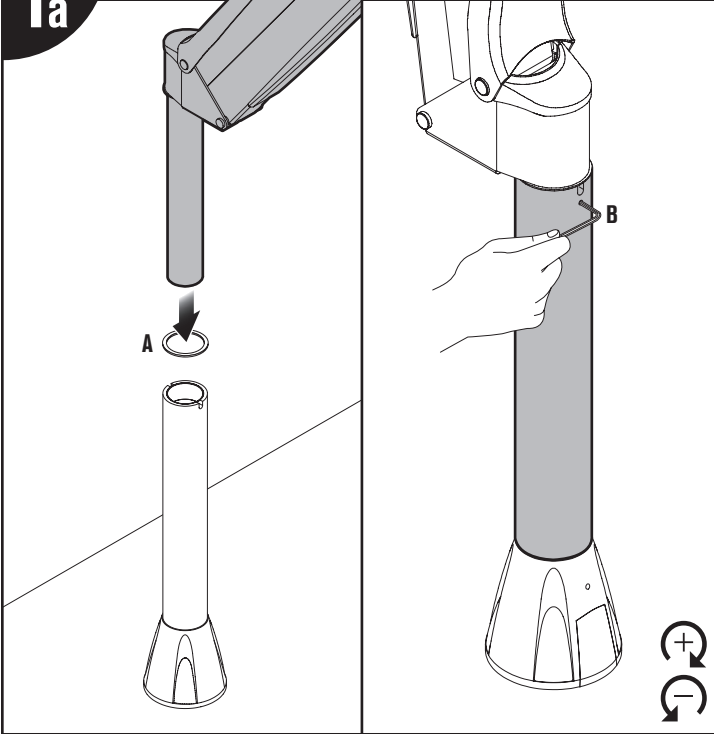

1b

8385 Wall Mount

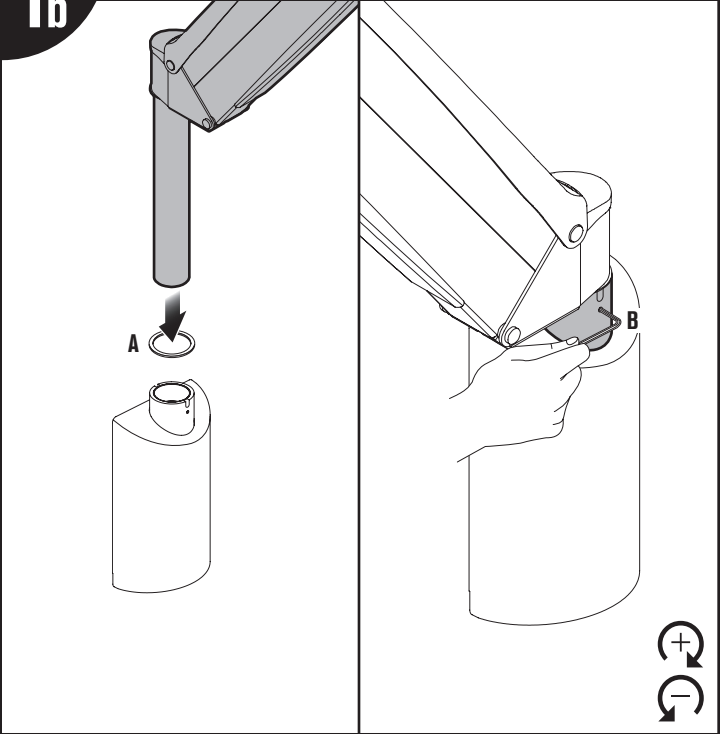

2a

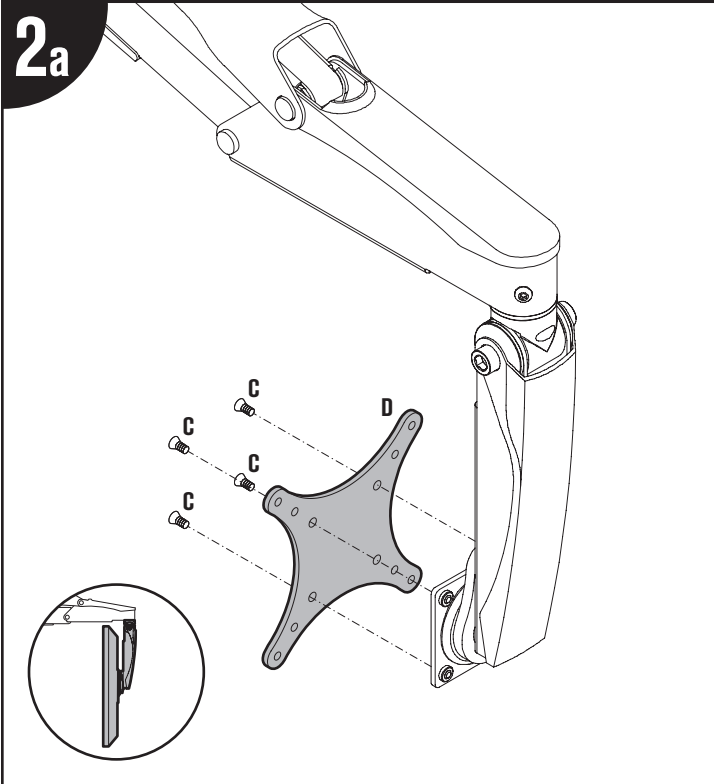

2b

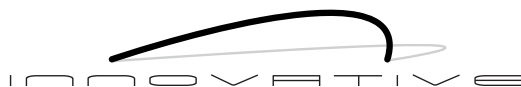
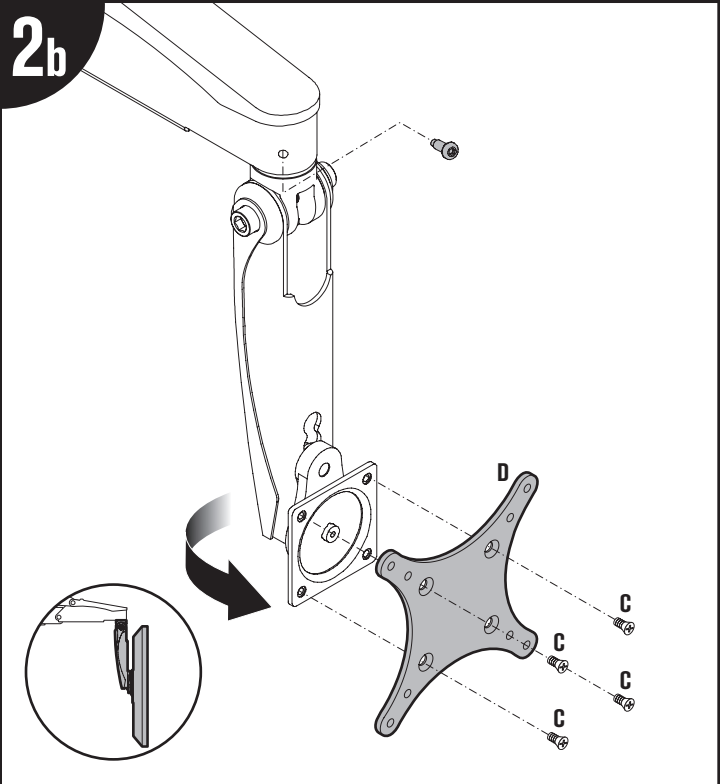

Model 9400 Installation Instructions

www.LCDarms.com | 800.524.2744

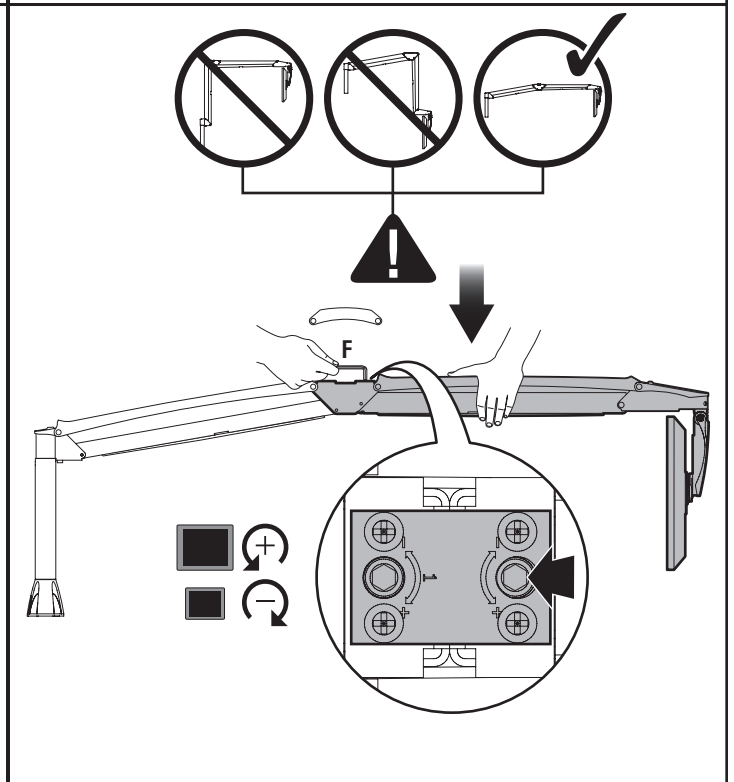
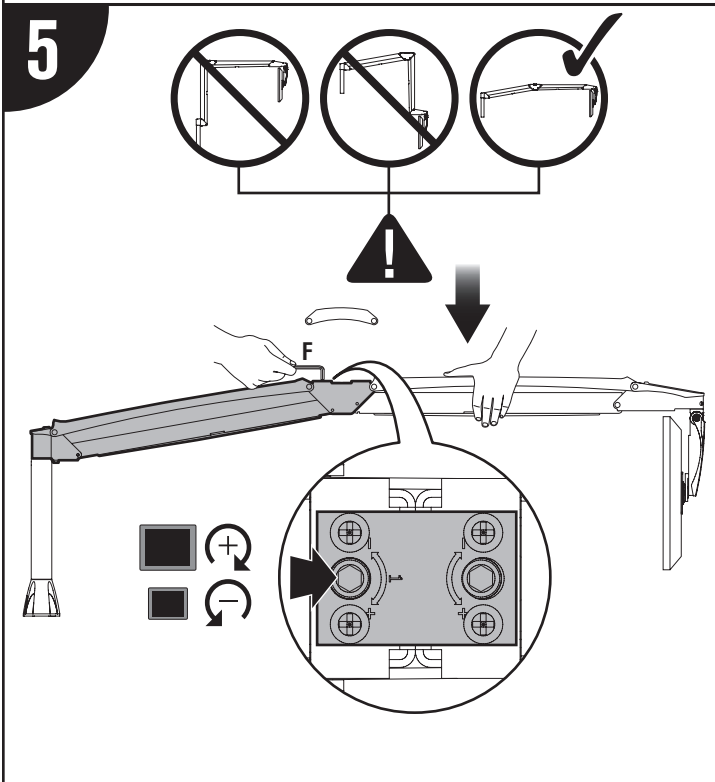
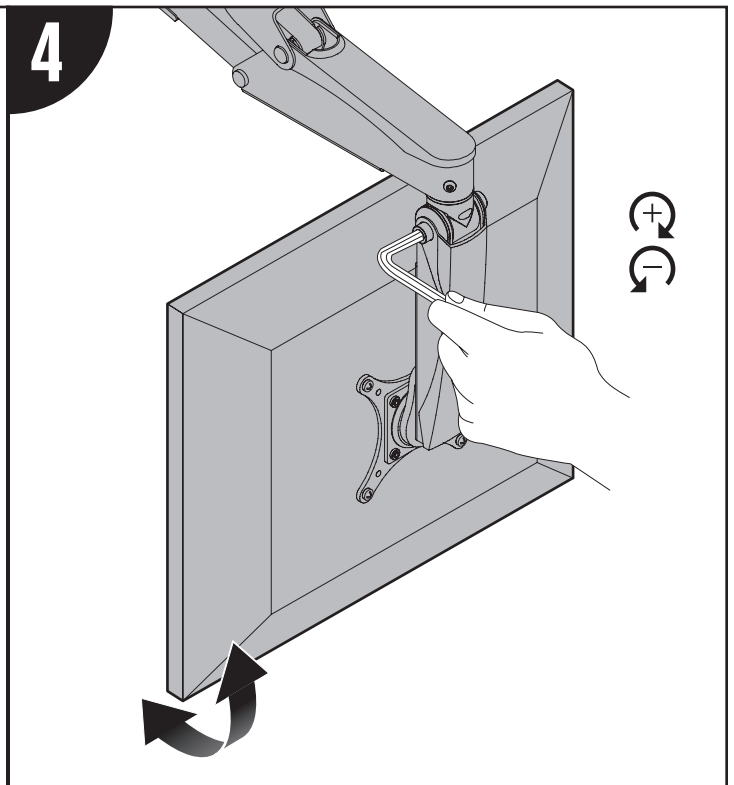
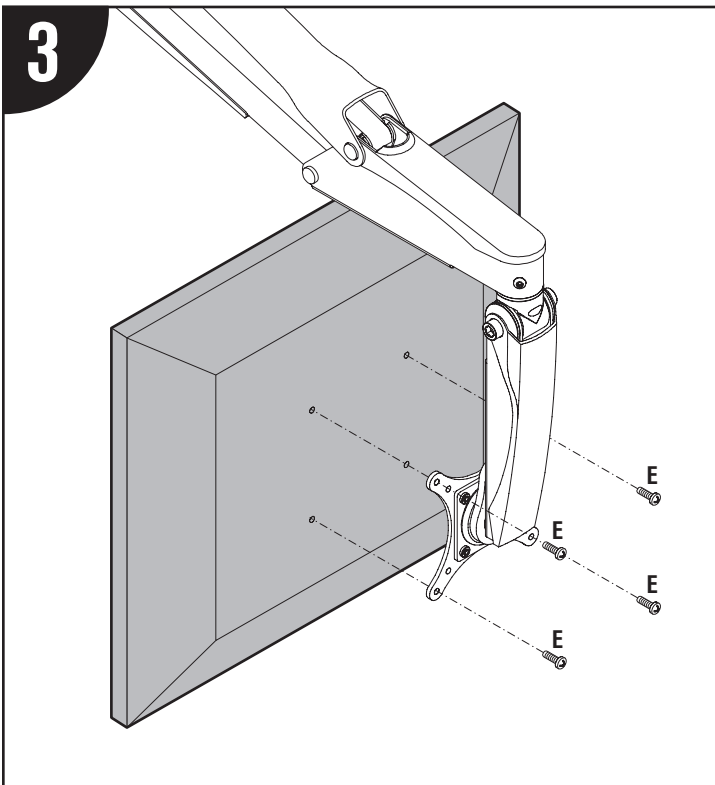

Model 9400 Installation Instructions

www.LCDarms.com | 800.524.2744

6a

8384 Countertop Mount

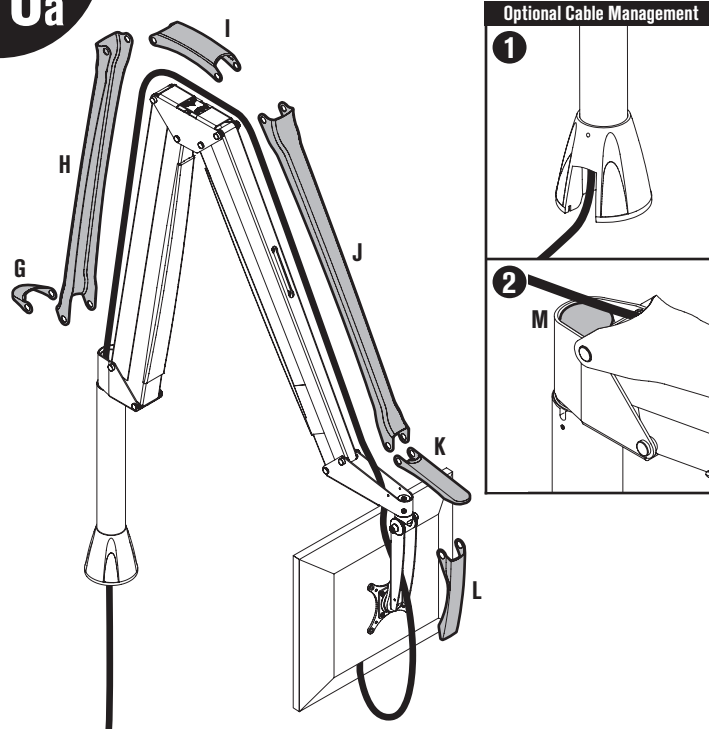

6b

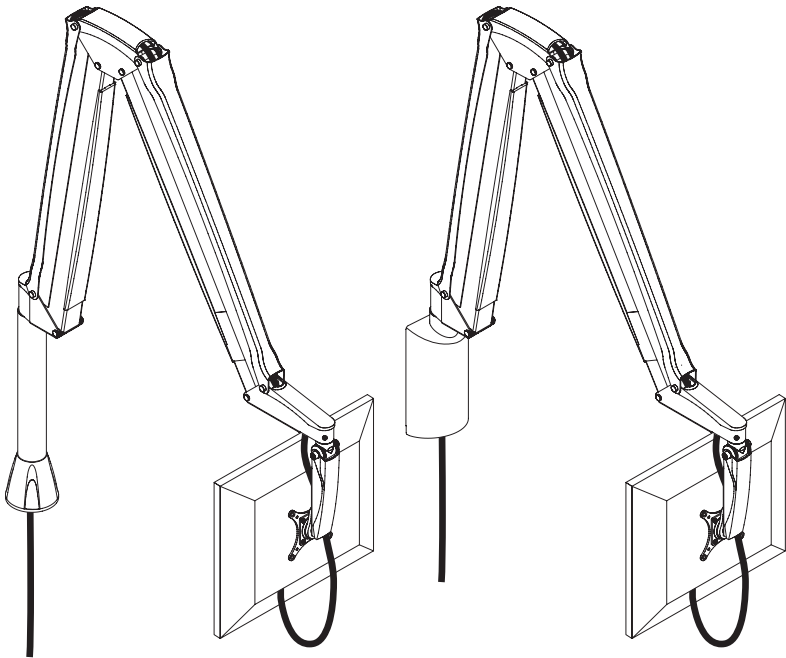
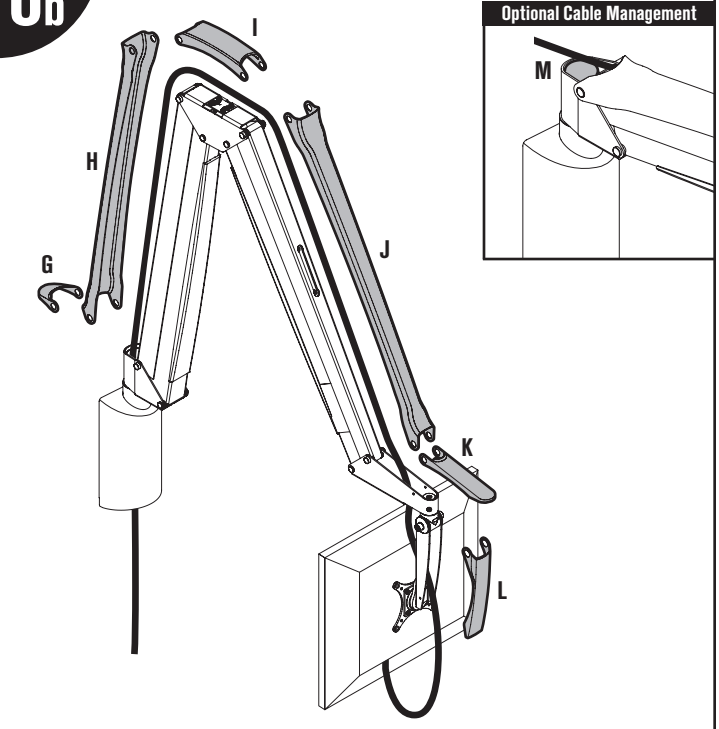

8385 Wall Mount



800.524.2744
www.LCDarms.com

Model 9400 Parts List

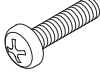
www.LCDarms.com | 800.524.2744

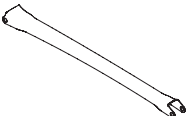
ITEM	DESCRIPTION / PART NO.	QUANTITY
A 	Thrust Washer 702833	1
B 	3/32" Allen Wrench 700146	1
C 	10-32 x 3/8" Phillips Flat Head Screw 702281	1 (4-pack)
D 	75mm and 100mm Starfish VESA Adapter Plate 105587	1
E 	M4-12 Phillips Pan Head Screw 702096	4
F 	7/32" Allen Wrench 701127	1
G 	Lower End Cap Cover 106000	1
H 	Upper End Cap Cover 106002	1
I 	Upper Channel Arm 1 106594	2
J 	Middle End Cap Cover 106001	1
K 	Upper Channel Arm 2 106593	1
L 	Tilter Swing Arm Cover 106005	1
M 	End Cap Plug 707150	1