

Assembly & Installation Instructions: Sierra HXL Top Crank Workcenter SCTHXL42, SCTHXL48 & SCTHXL54

Parts Included

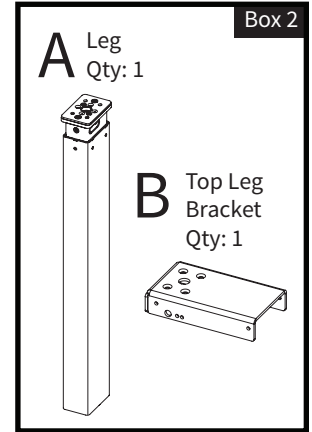

For SCFHXL42 & SCFHXL48 workcenters

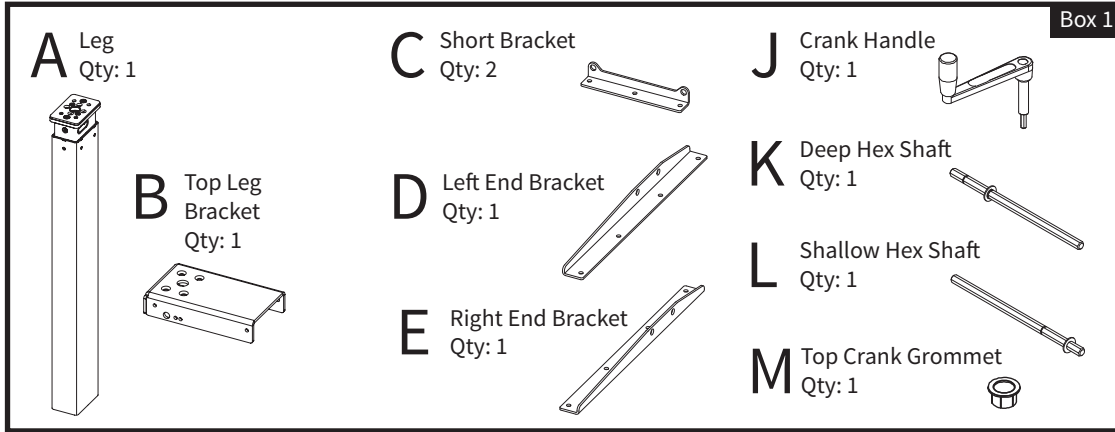
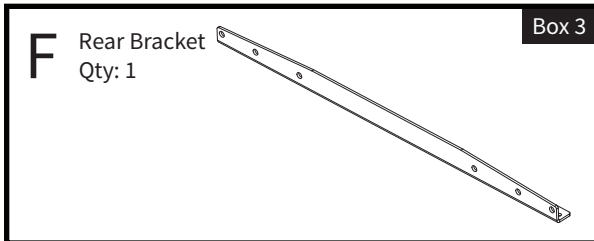

For SCTHXL54 workcenters

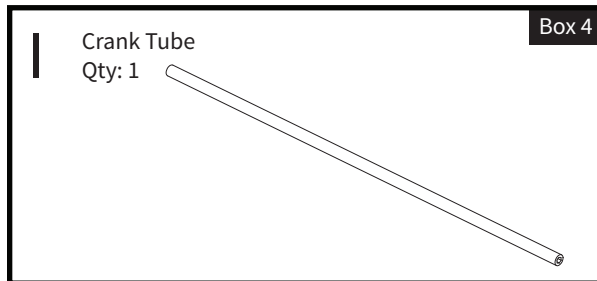
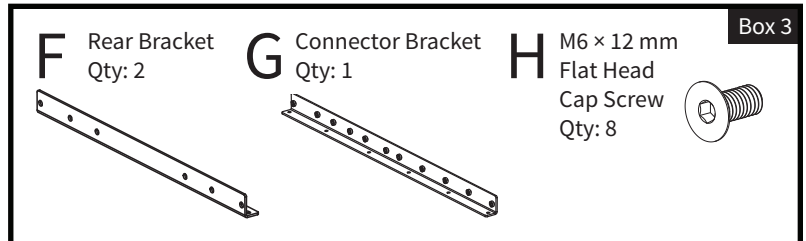

Hardware Kit 4225351-01

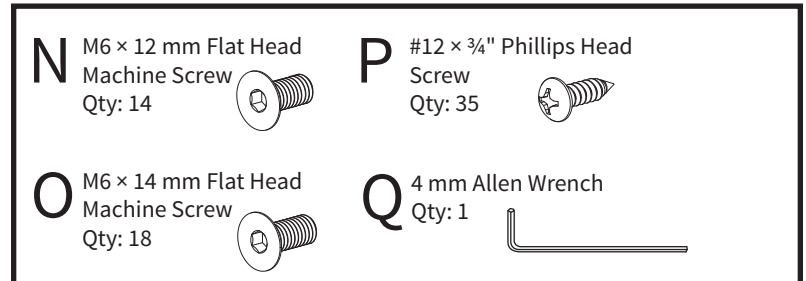

Required & Sold Separately

Styler or Flat Foot Kit
Worksurface



Verify that you have all the hardware and tools needed for the assembly

Check your cartons against the list above to verify that you have all the parts needed.

You will also need the following tools:

#2 tip Phillips screwdriver or drill/driver
#3 tip Phillips screwdriver or drill/driver

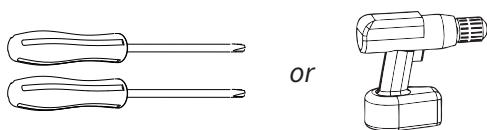

If you do not have a Workrite tabletop
you will also need:

Pencil

1/8" drill bit

3/4" spade drill bit

1 Layout Legs and Brackets

Lay out Legs (A) and Brackets (B, C, D, E, F and G) and Crank Tube (H) on the floor.

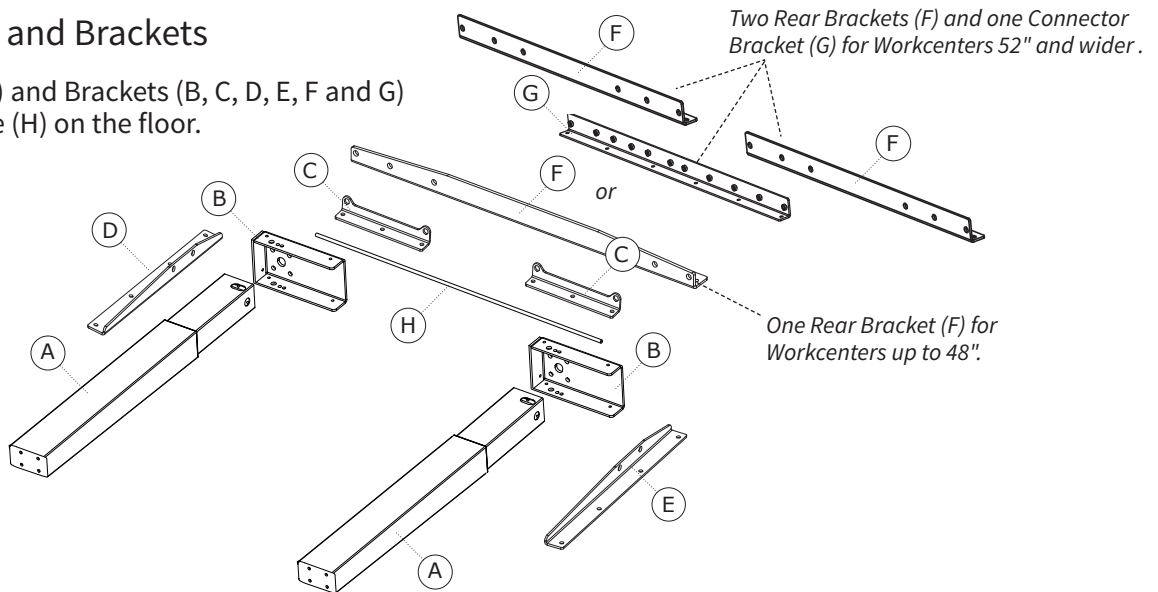

2 Attach Top Leg Bracket to Legs

Note: Right and Left Legs (A) and Top Leg Brackets (B) are interchangeable.

Attach one Top Leg Bracket (B) to the top of each Leg (A) using M6 × 14 mm Flat Head Screws (O) with the supplied Allen Wrench (Q).

 To avoid stripping the threads, always insert and make the first few turns of the screw **BY HAND** with an Allen wrench (Q), ensuring it is in straight.

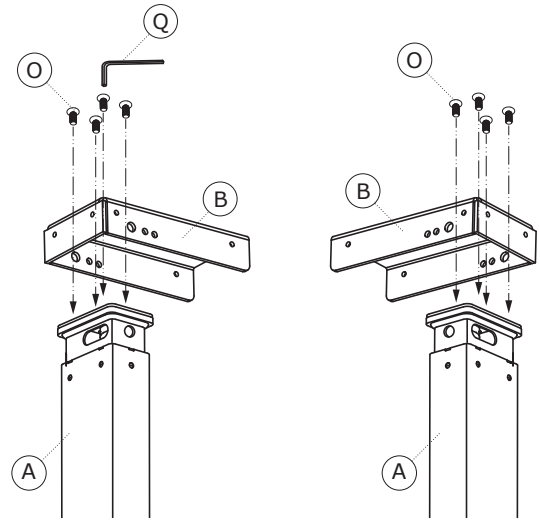

3 Attach Short and Medium Brackets to Leg Assembly

Attach both Short Brackets (C) to the Top Leg Brackets (B) using M6 × 12 mm Flat Head Screws (N).

Tighten securely.

Attach Left & Right Brackets (D & E) to the Top Leg Brackets (B) using M6 × 12 mm Flat Head Screws (N).

Tighten securely.

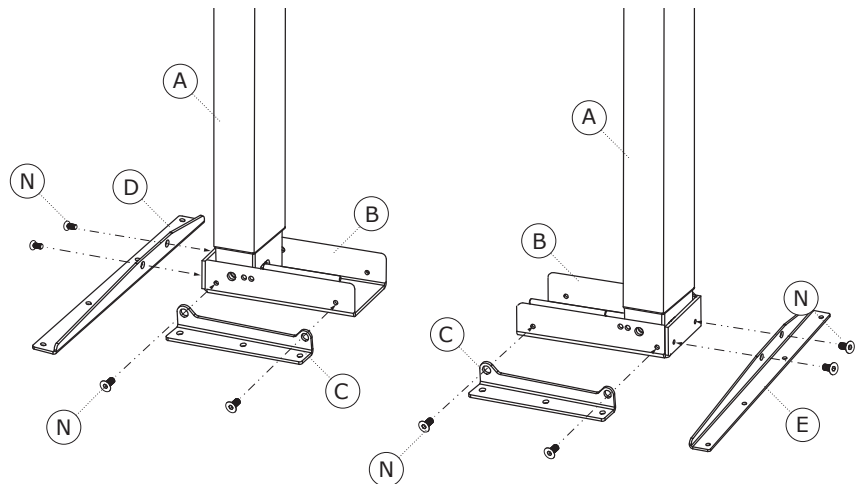

4 Assemble Rear Brackets to Connector Bracket for Worksurfaces larger than 48"

For SCTXHL42 & SCTXHL48 workcenters: If your Worksurface is under 52" wide you will not need to make an assembled Rear Bracket. You will use the single Rear Bracket included with your frameset and proceed to **Step 5**.

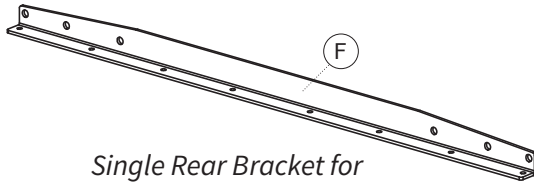

*Single Rear Bracket for
42" & 44" Workcenters*

For SCTXHL54 workcenters only:

Assemble Rear Brackets (F) to Connector Bracket (G) using #M6 × 12 mm Flat Head Cap Screws (H) included with Brackets.

Use this guide to determine the correct holes for mounting based on the width of your workcenter.

Tighten securely.

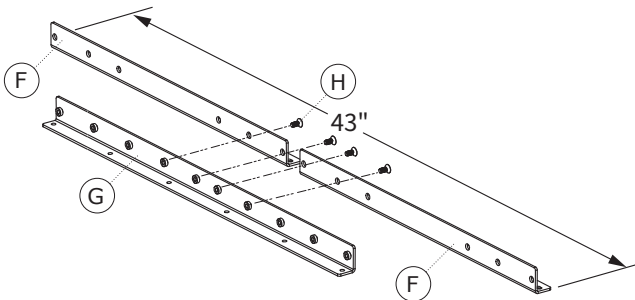
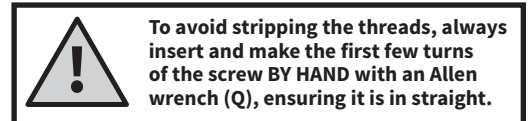

*Assembled Rear Bracket for
54" Workcenters*

5 Attach Rear Bracket to Left Leg

Attach single Rear Bracket or Rear Bracket assembly to back of Left Leg Bottom Bracket using M6 × 12 mm Flat Head Screws (H) or (N).

Tighten securely.

Note: M6 × 12 mm Flat Head Screws are provided with both the main hardware kit (N) and with the connected brackets (H). If your configuration uses an Assembled Rear Bracket, use the Screws (H) supplied with the brackets.

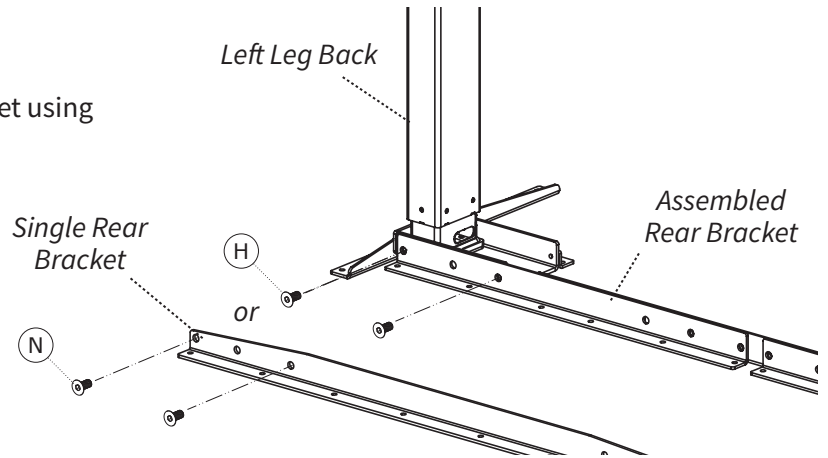

6 Attach Legs to Hex Shafts and Crank Tube

a Right Leg: Insert short end of Deep Hex Shaft (K) into leg. Slide Crank Tube (I) over Deep Hex Shaft. The Deep Hex Shaft is designed to go through the leg and engage the gear on the far side of the leg.

b Left Leg: Pull Leg assemblies together and insert the short end of Shallow Hex Shaft (L) into leg. Slide Crank Tube (I) over Shallow Hex Shaft. The Shallow Hex Shaft is designed to go engage the gear on the near side of the leg.

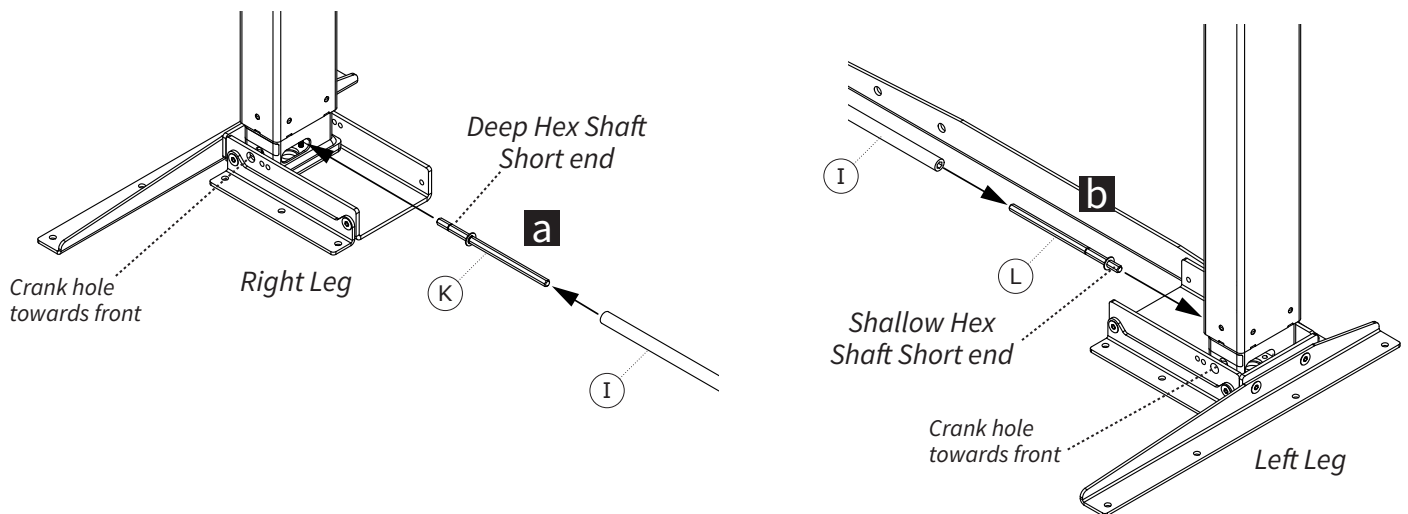

7 Attach Rear Bracket to Right Leg

Attach Rear Bracket to back of Right Leg Cap using M6 × 12 mm Flat Head Screws (H or M).

Tighten securely.

Note: M6 × 12 mm Flat Head Screws are provided with both the main hardware kit (N) and with the connected brackets (H). If your configuration uses an Assembled Rear Bracket, use the Screws (H) supplied with the brackets.

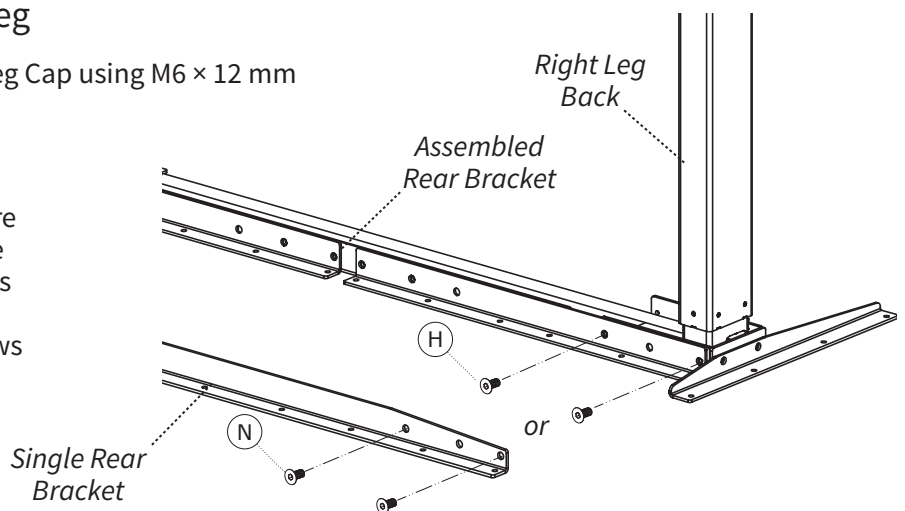

8 Attach Base to Worksurface — Workrite Worksurfaces

Note: If you do not have a Pre-Drilled Workrite Worksurface, skip to **Step 9**.

- a** Position leg assembly to align mounting holes in brackets to pre-drilled holes in worksurface.
- b** Attach at the four corner locations using #12 × 3/4" Phillips Head Screws (P). If you use an electric screwdriver, be sure it is on the lowest torque setting to avoid stripping the holes in the top.
- c** With frame set positioned and the four corner screws secure, attach frame set using the remaining #12 × 3/4" Phillips Head Screws (P).

Tighten securely.

Skip to **Step 10**.

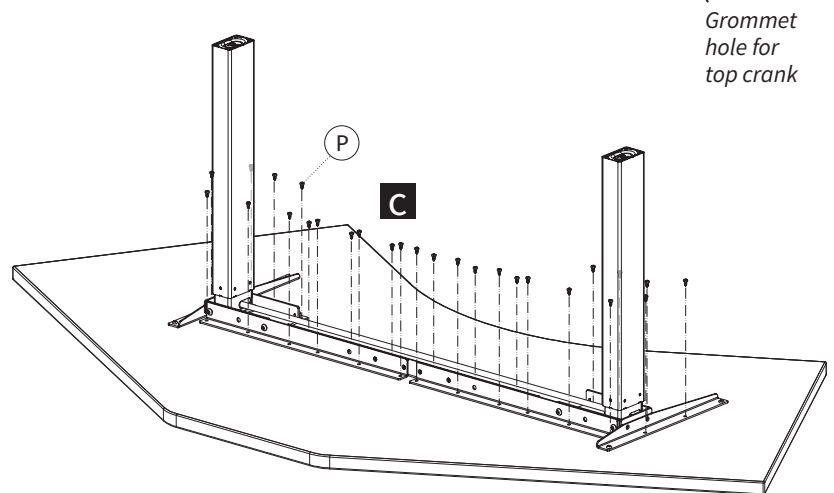
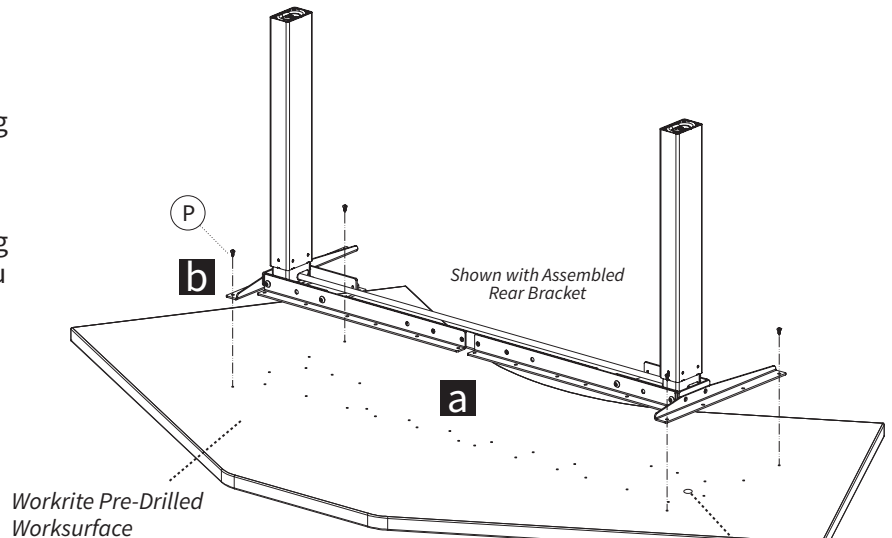

9 Attach Base to Worksurface — Non-Workrite Worksurfaces

Note: For 2-Leg Corner and 120° Worksurface Mounting Instructions, go to: www.workriteergo.com/instructions/ and look under Worksurface Mounting Instructions for more detail.



Note: Avoid trip or tip hazards!

For uniquely shaped, non-rectangular worksurfaces, it is the installer's responsibility to position the worksurface to minimize extended overhangs and position feet fully under the worksurface.

a Position Leg Assembly centered left to right, making sure the frame runs parallel with the back edge of the worksurface. Trace around outside of leg bracket and mark all bracket hole locations.

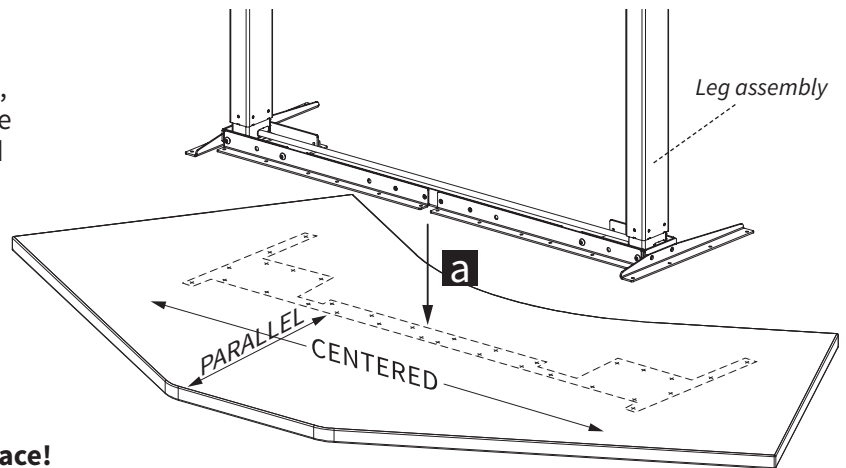

b Drilling Bracket holes: Use a $\frac{1}{8}$ " drill bit to drill pilot holes at all the bracket hole locations. You may wish to mark your drill bit so you do not drill any more than $\frac{3}{4}$ " deep and damage your worksurface top.

! Do not drill all the way through worksurface!

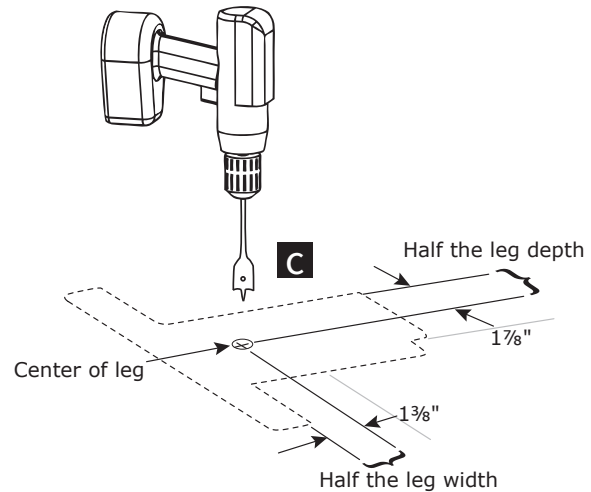
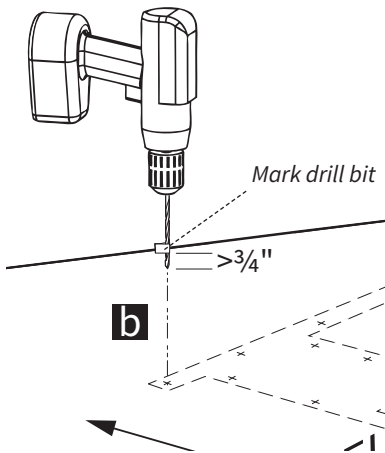

c Drilling Crank Handle hole: Set aside the leg assembly. Use the tracing to measure from front left corner of leg bracket as shown, then mark the Crank Handle hole placement. The hole should be directly under the center of the leg.

Drill a $\frac{1}{8}$ " pilot hole **completely through the worksurface** from under the worksurface with the $\frac{1}{8}$ " drill bit. **DO NOT use the $\frac{3}{4}$ " spade drill bit until next step!**

d Flip the Worksurface over. Locate the pilot hole you just made and use it to guide drilling a $\frac{3}{4}$ " grommet hole with $\frac{3}{4}$ " spade drill bit.

Flip the Worksurface back upside down.

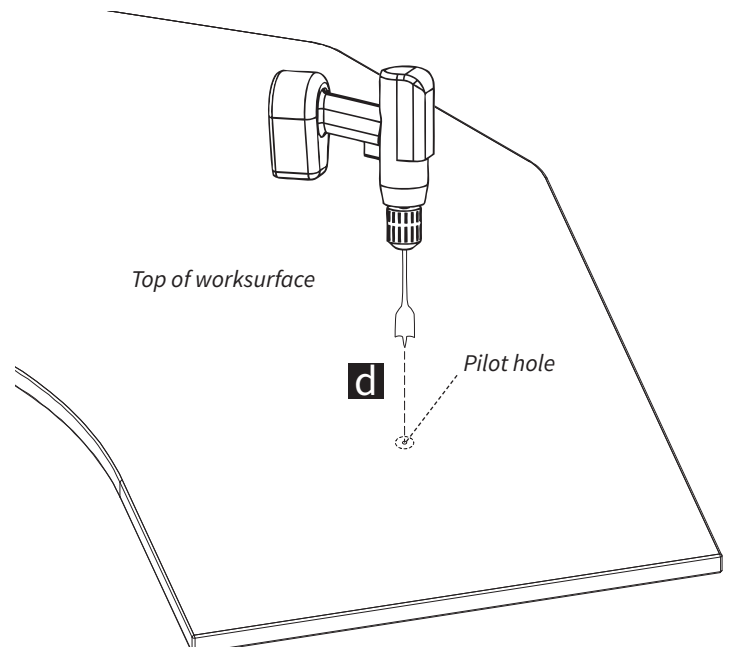

9 Attach Base to Worksurface — Non-Workrite Worksurfaces (continued)

- e** Attach at the four corner locations using #12 × ¾" Phillips Head Screws (P). If you use an electric screwdriver, be sure it is on the lowest torque setting to avoid stripping the holes in the top.

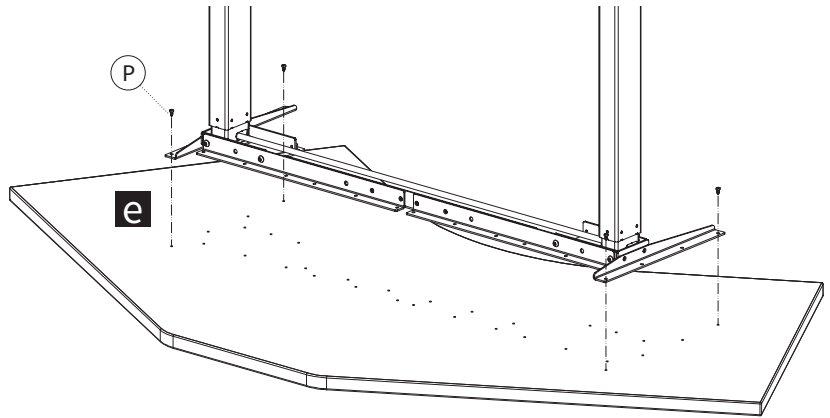

- f** With frame set positioned and the four corner screws secure, attach the frame set using the remaining #12 × ¾" Phillips Head Screws (P).

Tighten securely.

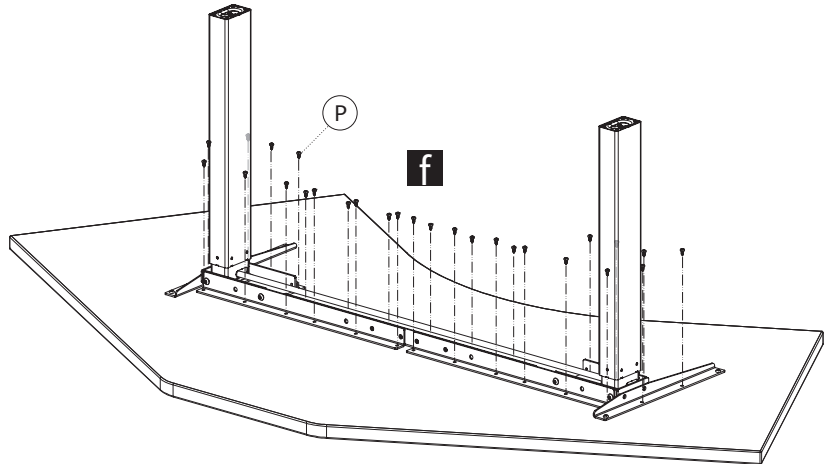

10 Attach Feet (sold separately)

Refer to foot kit instructions for steps to install your feet.

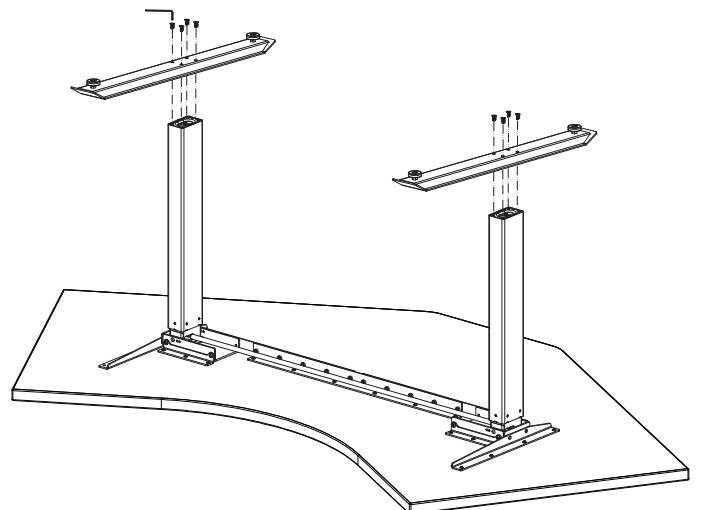

11 Confirm All Screws are Tightened and Flip Table Over

Tighten all screws in frame assembly and tighten all screws connecting frame to worksurface. Flip table over.
CAUTION: Use at least two people to flip over an assembled workcenter.



12 Install Crank Handle

Place Top Crank Grommet (M) into the $\frac{3}{4}$ " hole in the worksurface.

Insert Crank Handle (J) through Grommet and worksurface into the leg so that it engages the gearbox. Turn Handle to raise or lower table.

Crank Handle can be removed and stored when height adjustment is not needed.

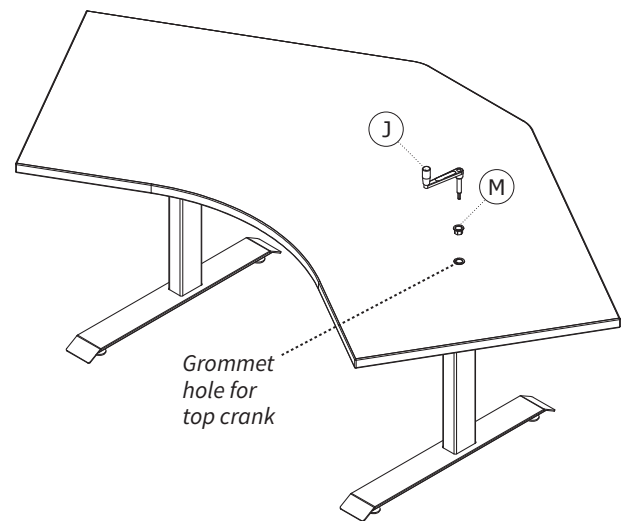

13 Adjust Leveling Guides

If necessary, adjust leveling guides on table feet to level the worksurface.