

StyleView® SV42 Cart with Laptop Mount

www.ergotron.com

USA 1-800-888-8458

Europe +31 (0)33-45 45 600

China 86-769-86018920

For the latest User Installation Guide and StyleLink Software Download please visit:

Encontrará la versión más reciente del manual de instalación del usuario y el software de StyleLink en:

Si vous souhaitez télécharger le dernier manuel d'installation de l'utilisateur ou le logiciel StyleLink, rendez-vous sur :

Den neuesten Installationsleitfaden für Benutzer sowie den neuesten StyleLink-Software-download finden Sie unter:

Voor de nieuwste Installatiehandleiding voor de gebruiker en voor het downloaden van StyleLink-software gaat u naar:

Per scaricare le versioni più recenti del manuale di installazione e del software StyleLink, andare al sito:

De senaste versionerna av installationshandledningarna och nedladdning av programvaran för StyleLink finns på:

最新版ユーザインストールガイドとスタイルリンク ソフトウェアは次のサイトでダウンロードできます。

请从下列地址获取最新版本的用戶安裝指南和 StyleLink 軟件下載：

StyleLink

<http://4support.ergotron.com>



User's Guide - English

Guía del usuario - Español

Manuel de l'utilisateur - Français

Gebruikersgids - Nederlands

Benutzerhandbuch - Deutsch

Guida per l'utente - Italiano

Användarhandbok - svenska

ユーザーガイド : 日本語

用戶指南 : 汉语



IMPORTANT! This product will need tension adjustments once installation is complete. Make sure all equipment is properly installed on the product before attempting range of motion or tension adjustments. Any time equipment is added or changed on this product resulting in a different mounted weight, you should repeat the adjustment steps to ensure safe and optimum operation. This product should move smoothly and easily through the full range of motion and stay where you set it. If movement is difficult or the product does not stay where you set it, follow the adjustment instructions to loosen or tighten the tension to create a smooth, easy motion. Depending on your product and the adjustment, it may take many turns to notice a difference.

Features & Specifications 2 - 4

Set-up 5 - 15

Adjustment 13

Battery Charge/Discharge 14

Auto-Lock Drawer 15

Change Fuse (1 Amp) and Reset Circuit Breakers 16

Change Power System Batteries 17 - 18

Cart Storage (long term/short term) 19

Ergonomics 20

Maintenance & Safety 20 - 23

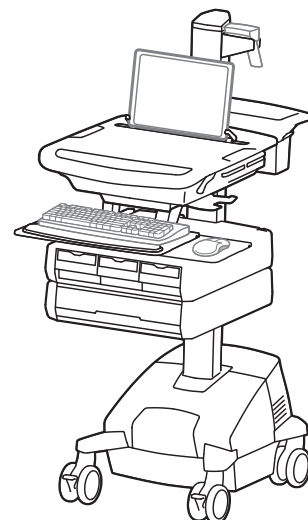

StyleView powered carts provide electrical AC power for mobile point of care computing equipment in a healthcare environment. The carts are not intended to power medical products or devices. Outlets are provided to power information technology equipment only such as computer equipment and computer peripherals.

	A	B	C
1	1x		3x
2	1x 1x		1x
3	1x	1x M4 x 8mm	1x
4	1x	1x	2x
5	1x 1x	1x	2x
6	1x	9x	2x
7	1x 2x	2x M4x12mm	

For service and warranty visit www.ergotron.com

Si desea información de servicio y garantía, visite www.ergotron.com

Pour toute question concernant la garantie ou le service client, consultez www.ergotron.com

Weitere Informationen zu Service und Gewährleistung erhalten Sie unter www.ergotron.com.

Ga voor service en garantie naar www.ergotron.com

Per assistenza e la garanzia visitare www.ergotron.com

Gå in på www.ergotron.com för service och garanti

サービスおよび保証について詳しくは、www.ergotron.com をご覧ください。

有关服务和保修，请访问 www.ergotron.com

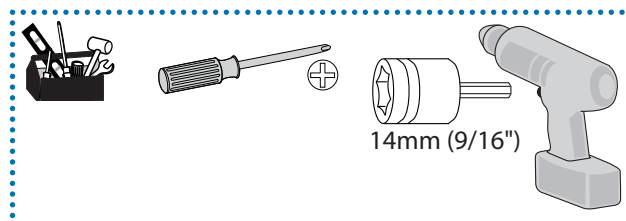

WARNING

Ø14mm (9/16")

IMPACT HAZARD!
MOVING PARTS CAN CRUSH AND CUT.

Minimize Lift Tension BEFORE:

- Removing Mounted Equipment.
- Shipping Cart
- Storing Cart

To Minimize Lift Tension

1. Lower worksurface to lowest position.
2. Turn adjustment nut at top of riser counterclockwise until it stops (Adjustment may require 40-60 revolutions).

Failure to heed this warning may result in serious personal injury or property damage!

For More information and instructions refer to product guide at <http://4support.ergotron.com> or contact Ergotron Customer Care at 1-800-888-8458.

822-052

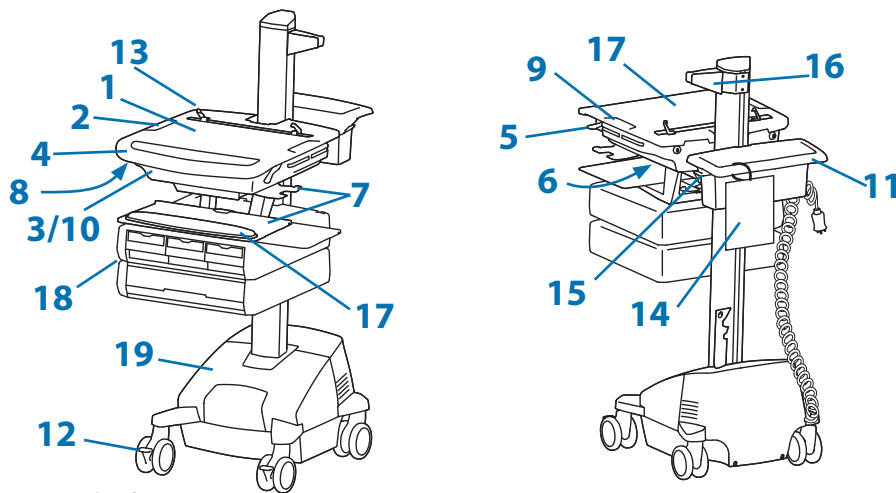

1. Worksurface
2. User Interface for Power System
3. Secure storage for open laptop
4. Front Handle
5. Height Adjustment Brake
6. USB Hub connects keyboard and mouse USB cables
7. Keyboard tray slides out, tilts and allows for right or left mousing with attached mouse holder
8. Keyboard Light under Front Handle
9. Keyboard Light Switch
10. Cable Management and Storage for excess cables and power supplies
11. Storage Basket and Rear Handle
12. Front Locking Casters
13. Laptop Screen Holders
14. Quick Reference Card
15. Power Cord Hooks
16. Scanner Holder
17. Antimicrobial worksurface and antimicrobial coating on wrist rest
18. Auto-Lock Drawer (see page 3 for drawer configurations)
19. **Power System**

The StyleView AC Power System allows your power supply to travel with the cart. The Power System is integrated in the base of the cart and comes standard with 2 batteries, power module, User Interface (UI), outlet box and power cord.

- User Interface (UI): Allows power system output to be turned on or turned off, monitors battery charge remaining, and provides low battery charge audible alarm.
- Two 33 Ah Sealed Lead Acid, Absorbed Glass Mat, 12VDC batteries.
- The minimum operational temperature is 10°C (50°F) and the maximum operational temperature is 29°C (86°F). The recommended humidity range for operation is 5-95% rH.
- The recommended cart storage temperature is 15°C (59°F). At this temperature, the battery's age-related capacity loss is minimized. The minimum storage temperature is -20°C (-4°F) and the maximum storage temperature is 50°C (122°F). The recommended humidity range for storage is 5-95% rH.

This Class A digital apparatus complies with Canadian ICES-003.

Cet appareil numérique de la classe A est conforme à la norme NMB-003 du Canada.

FCC Compliance Statement

The cart has been tested and found to comply with the limits for a Class A digital device, pursuant to part 15 of the FCC Rules. These limits are designed to provide reasonable protection against harmful interference when the equipment is operated in a commercial environment. This equipment generates, uses, and can radiate radio frequency energy and, if not installed and used in accordance with the instruction manual, may cause harmful interference to radio communications. Operation of this equipment in a residential area is likely to cause harmful interference in which case the user will be required to correct the interference at his own expense.

Changes or modifications not expressly approved by Ergotron, Inc. could void the user's authority to operate the equipment.

Please contact Ergotron for complete EMC compatibility information.

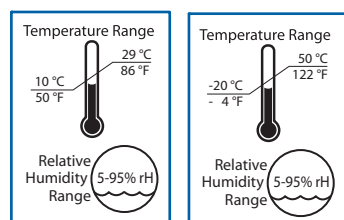

Operational

Storage



Features & Specifications

Part Number	Power System	Auto-Lock Drawer
SV42-3111-1	Input: 120VAC/60 Hz; 5.1A Output: 120VAC/60 Hz, 400VA/300W. • The cart and power system are certified to UL 60601 and CAN/CSA-C22.2 601.1-M90	1 Drawer*/16 compartments
SV42-3121-1	Input: 120VAC/60 Hz; 5.1A Output: 120VAC/60 Hz, 400VA/300W. • The cart and power system are certified to UL 60601 and CAN/CSA-C22.2 601.1-M90	2 Drawers*/32 compartments
SV42-3141-1	Input: 120VAC/60 Hz; 5.1A Output: 120VAC/60 Hz, 400VA/300W. • The cart and power system are certified to UL 60601 and CAN/CSA-C22.2 601.1-M90	4 Drawers*/28 compartments
SV42-3161-1	Input: 120VAC/60 Hz; 5.1A Output: 120VAC/60 Hz, 400VA/300W. • The cart and power system are certified to UL 60601 and CAN/CSA-C22.2 601.1-M90	6 Drawers*/24 compartments
SV42-3111-2 SV42-3111-3	Input: 230V~/50 Hz, 2.7A; Output: 230V~/50 Hz, 400VA, 300W. • The cart and power system are compliant with EN 60601-1.	1 Drawer*/16 compartments
SV42-3121-2 SV42-3121-3	Input: 230V~/50 Hz, 2.7A; Output: 230V~/50 Hz, 400VA, 300W. • The cart and power system are compliant with EN 60601-1.	2 Drawers*/32 compartments
SV42-3141-2 SV42-3141-3	Input: 230V~/50 Hz, 2.7A; Output: 230V~/50 Hz, 400VA, 300W. • The cart and power system are compliant with EN 60601-1.	4 Drawers*/28 compartments
SV42-3161-2 SV42-3161-3	Input: 230V~/50 Hz, 2.7A; Output: 230V~/50 Hz, 400VA, 300W. • The cart and power system are compliant with EN 60601-1.	6 Drawers*/24 compartments
SV42-3111-7 SV42-3111-8	Input: 230V~/60 Hz, 2.7A; Output: 230V~/60 Hz, 400VA, 300W.	1 Drawer*/16 compartments
SV42-3121-7 SV42-3121-8	Input: 230V~/60 Hz, 2.7A; Output: 230V~/60 Hz, 400VA, 300W.	2 Drawers*/32 compartments
SV42-3141-7 SV42-3141-8	Input: 230V~/60 Hz, 2.7A; Output: 230V~/60 Hz, 400VA, 300W.	4 Drawers*/28 compartments
SV42-3161-7 SV42-3161-8	Input: 230V~/60 Hz, 2.7A; Output: 230V~/60 Hz, 400VA, 300W.	6 Drawers*/24 compartments

*Auto-Lock Drawer

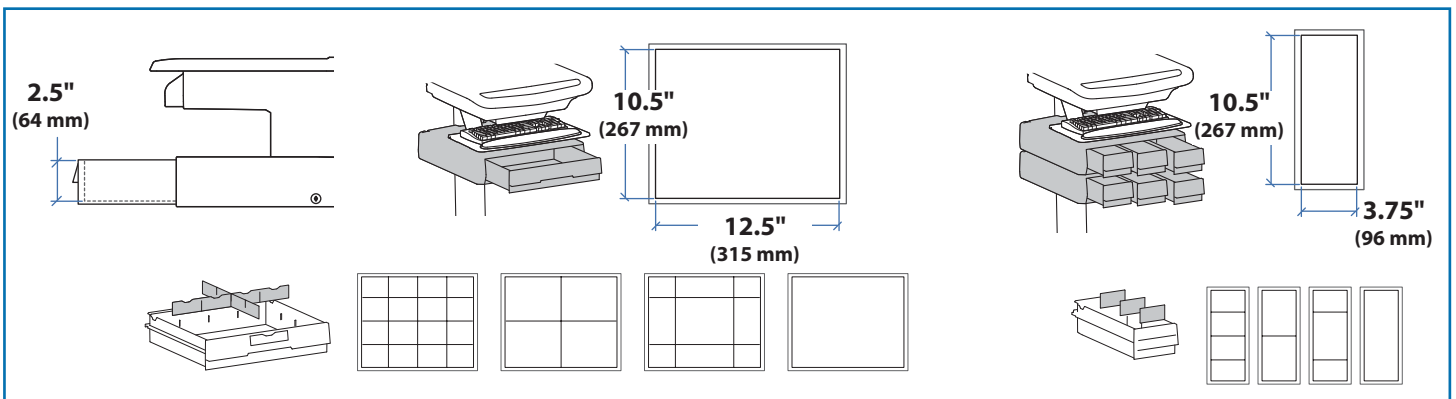
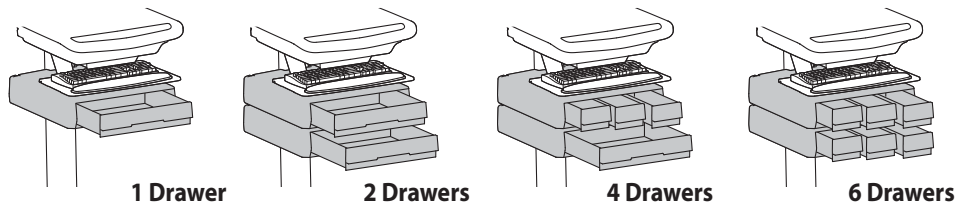

Features & Specifications

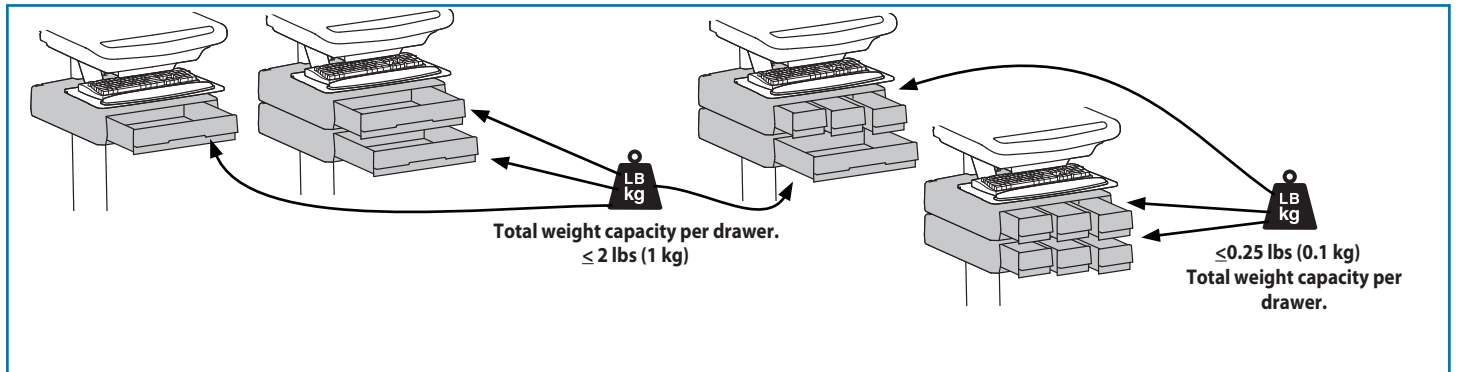
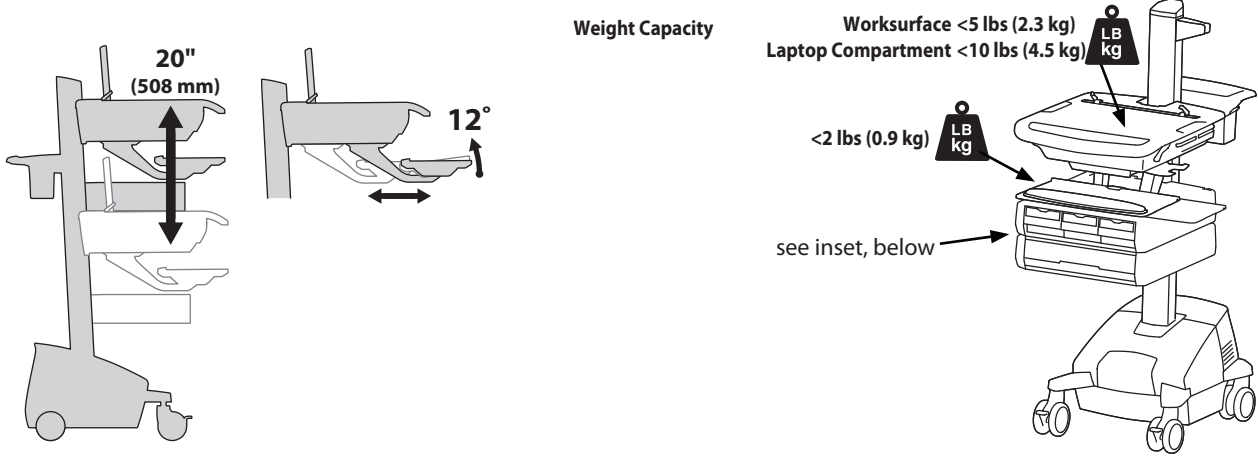

Dimensions

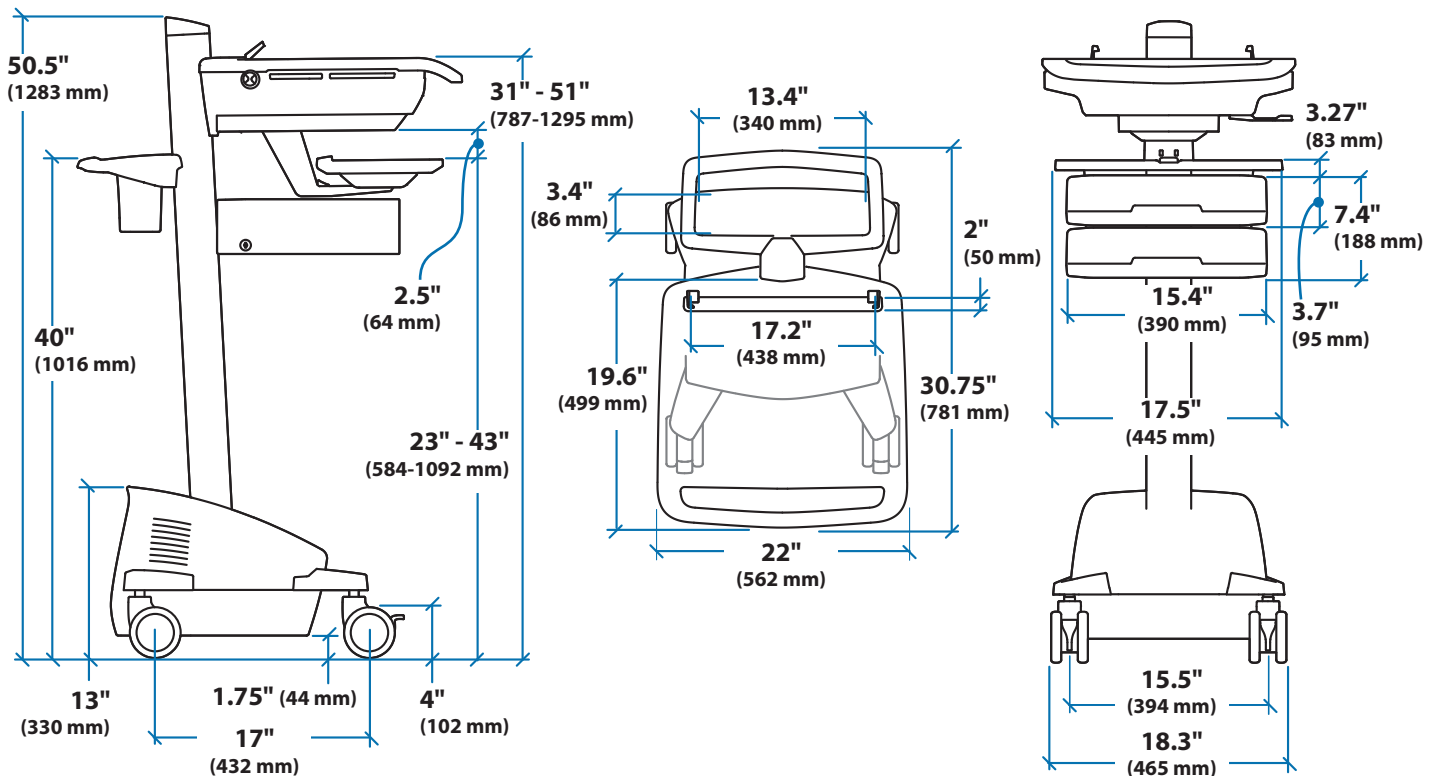

Laptop Compartment

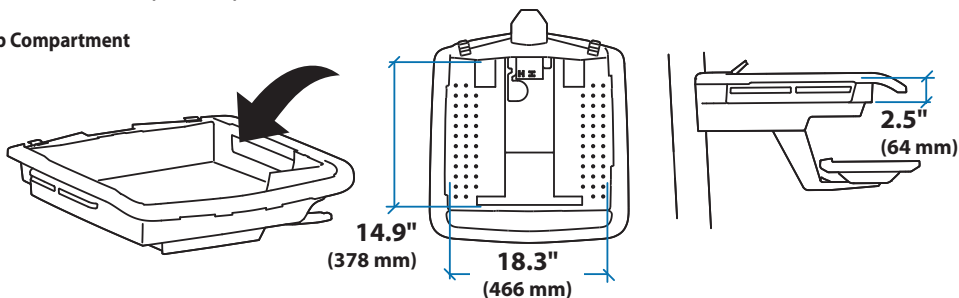

When figuring dimensions, include mounted accessories, protruding cables and port replicators or docking stations.

1 a

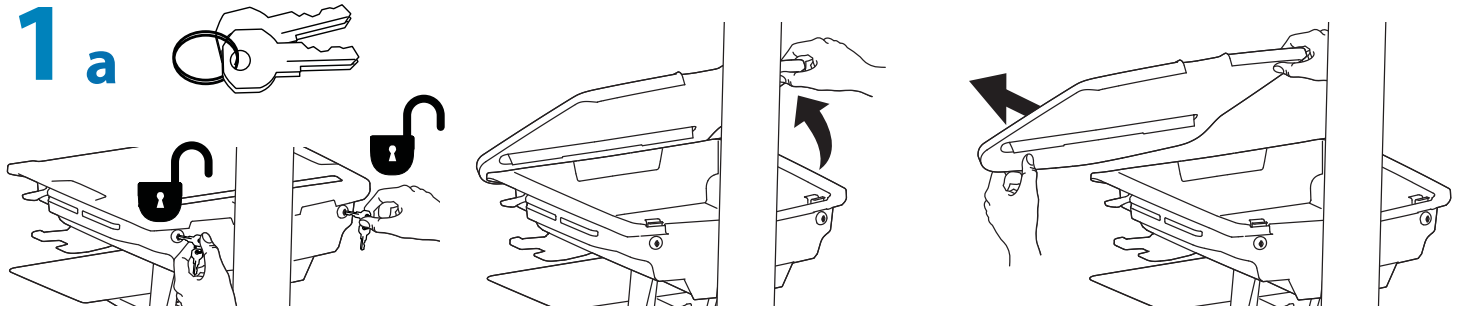

b

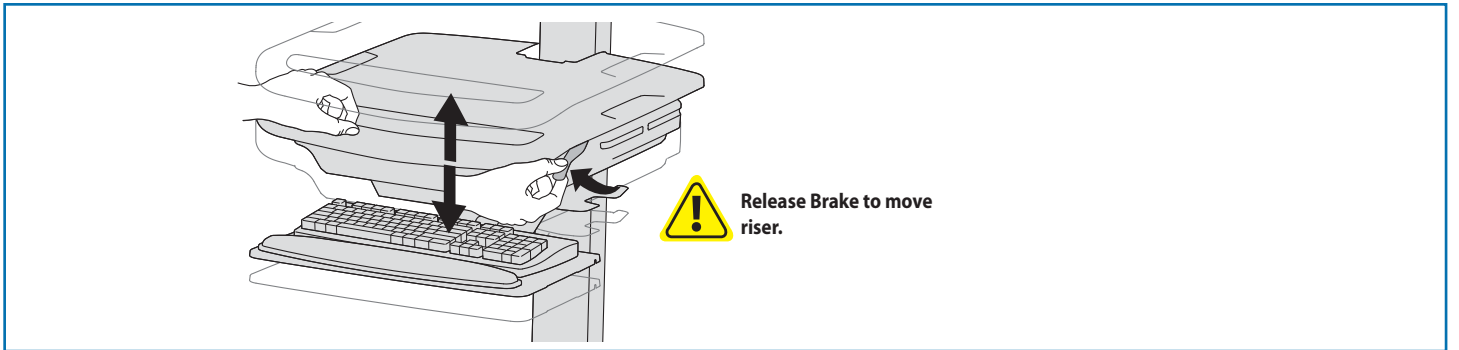
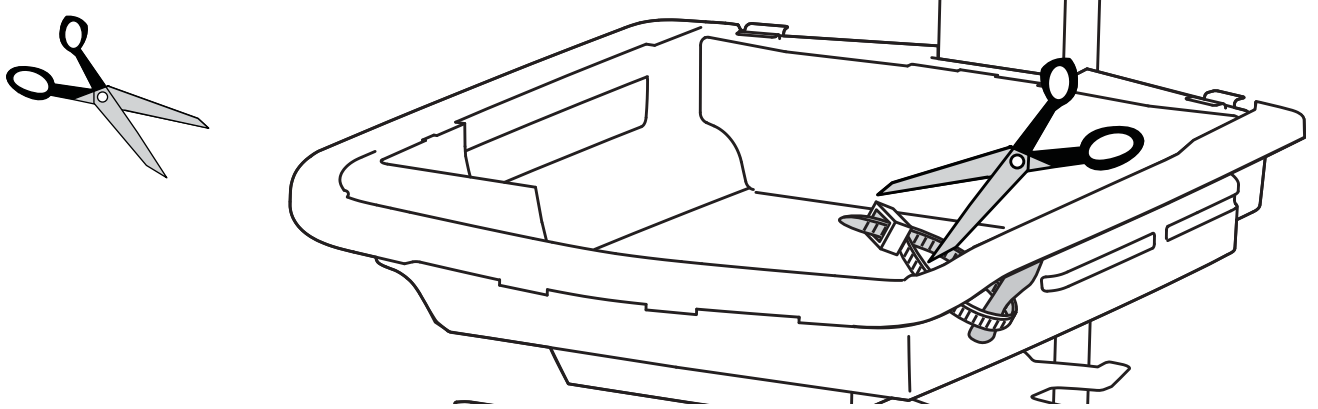

c

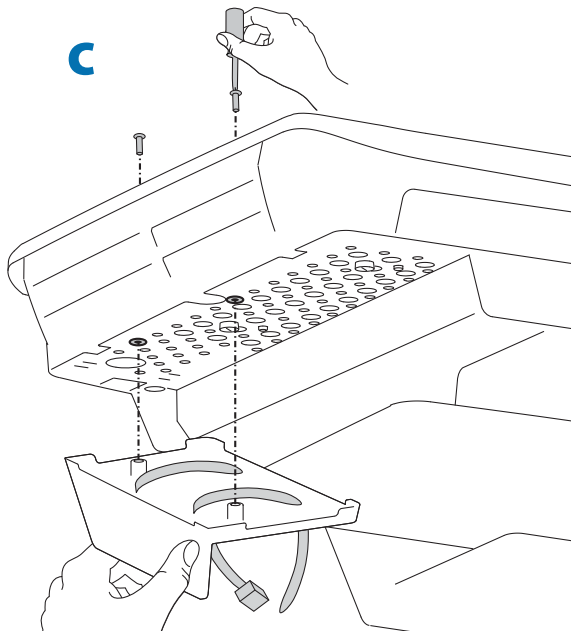

d

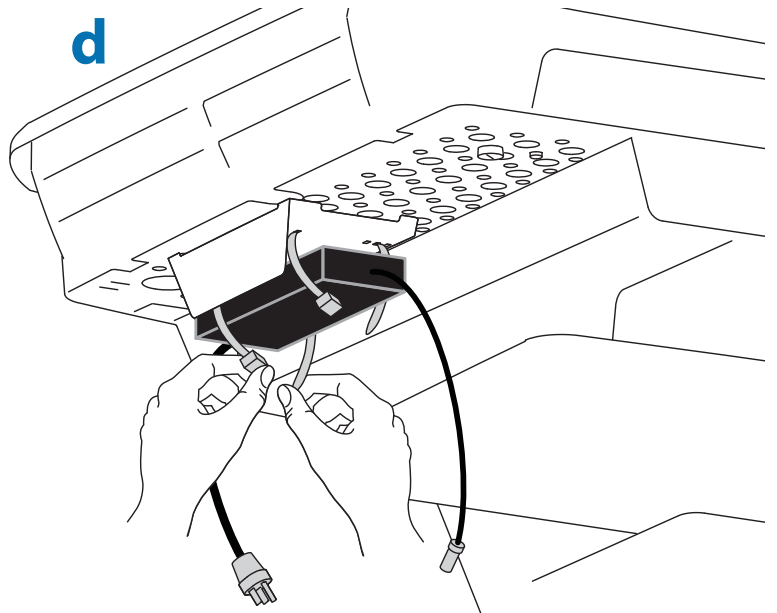

2 a

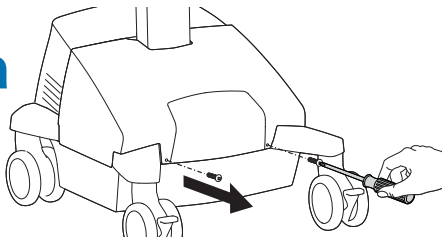

b

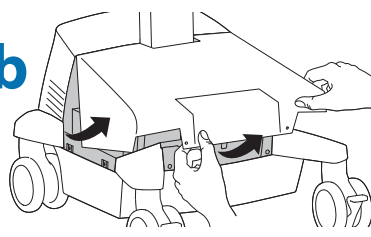

c

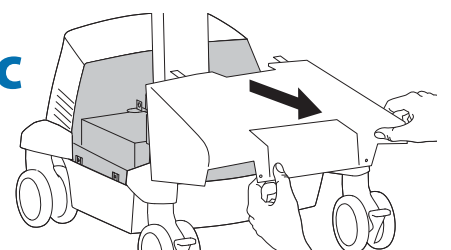

Set-up

3 Plug in power cables.

If you do not have power outlets located here, then follow steps 'a' - 'd' to route power cables.

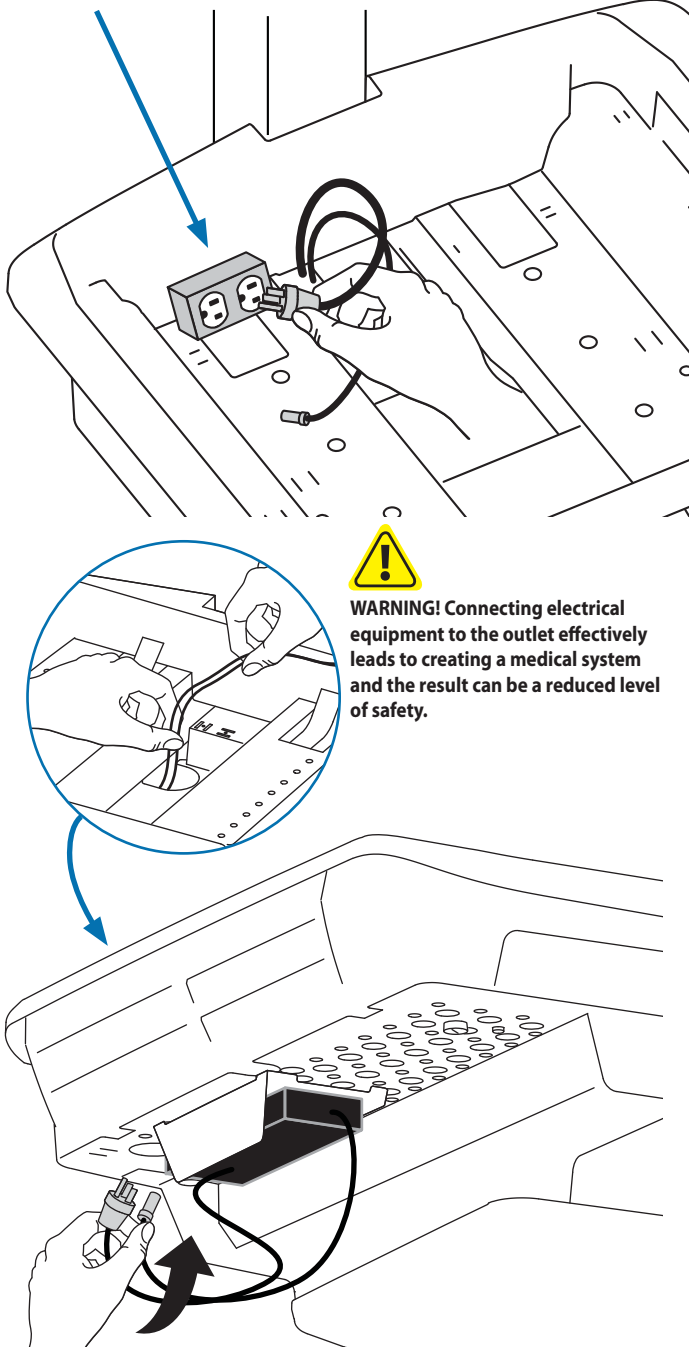

→ **4**

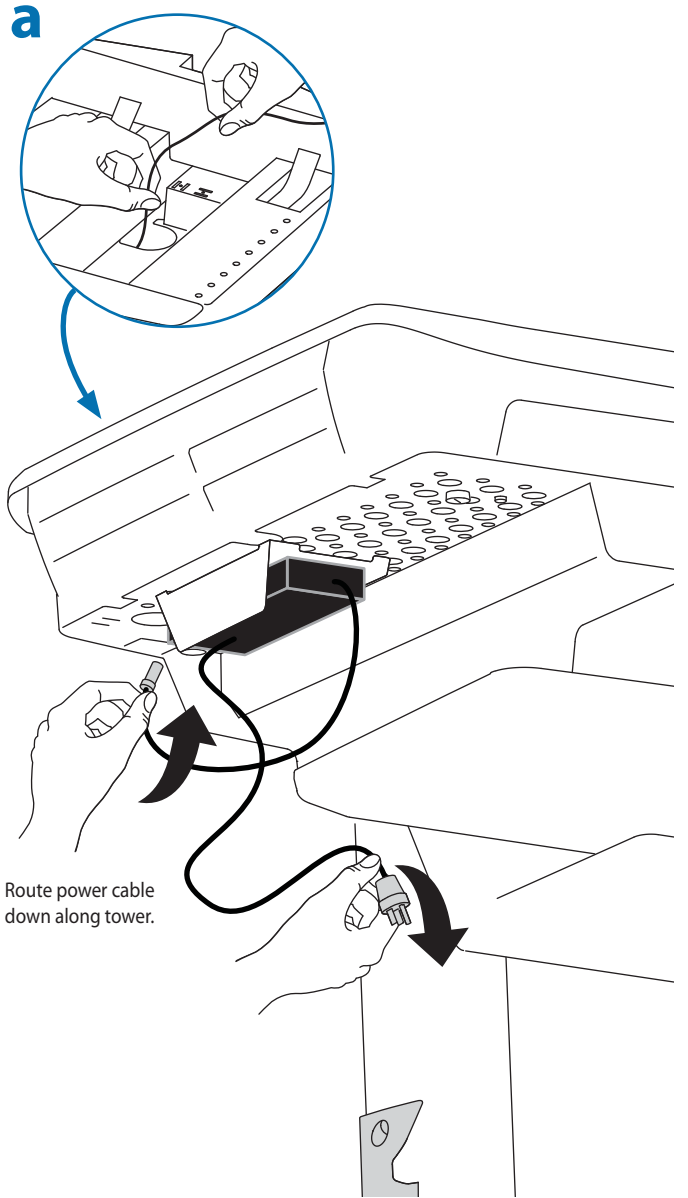

b - d →

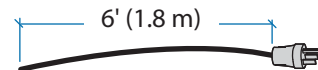

Power cables need to be 6' (1.8 m) long.

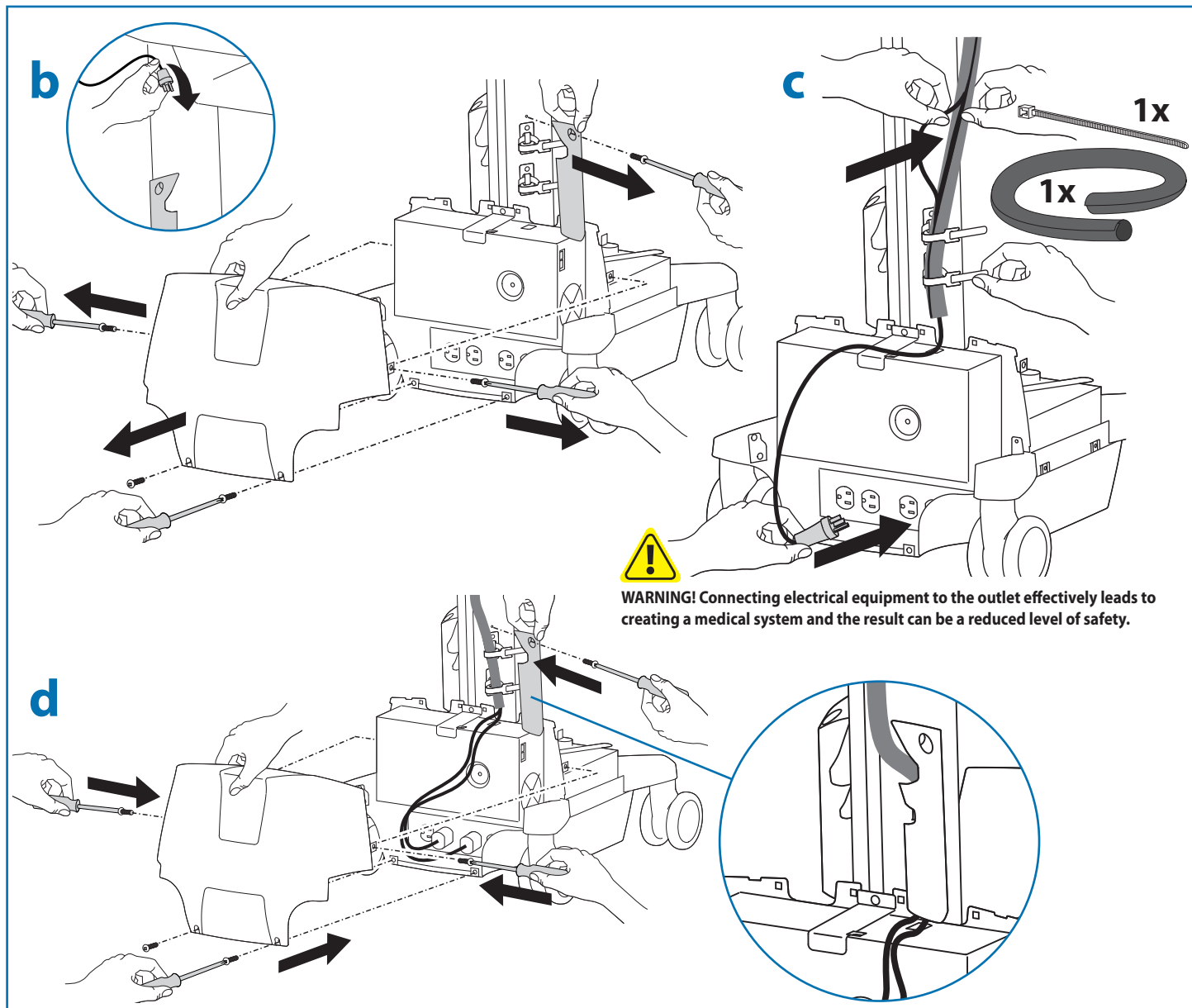

WARNING! Connecting electrical equipment to the outlet effectively leads to creating a medical system and the result can be a reduced level of safety.

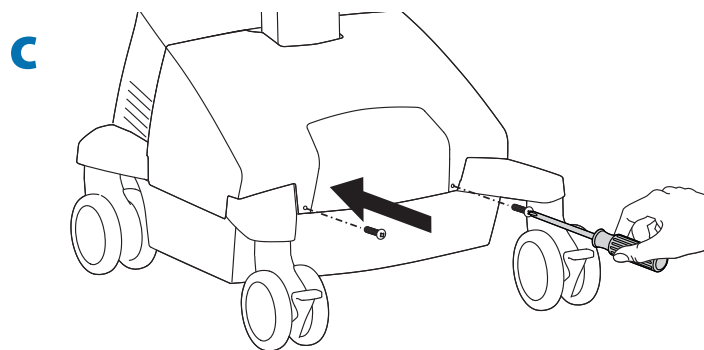
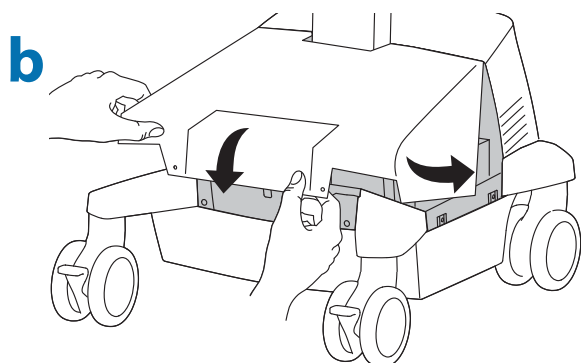
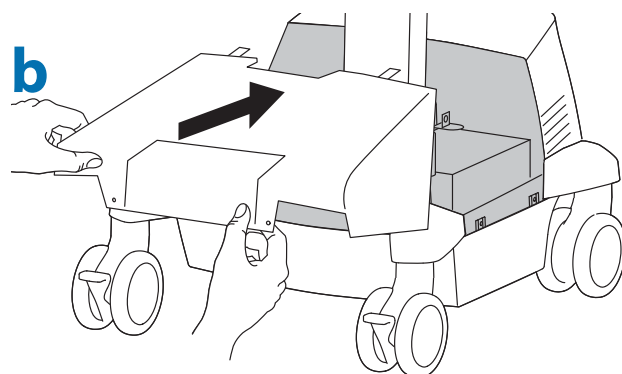
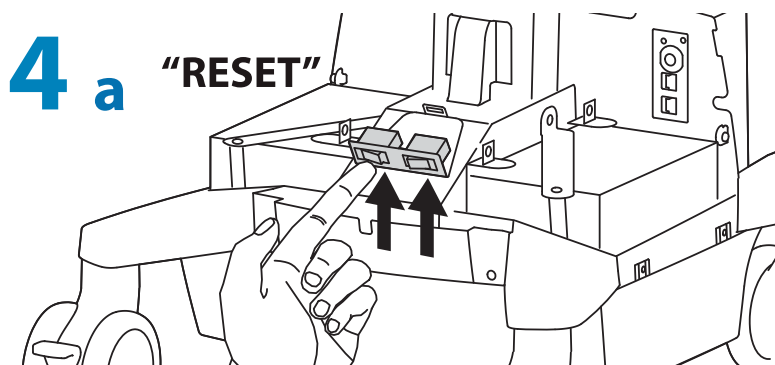

Set-up

5 a

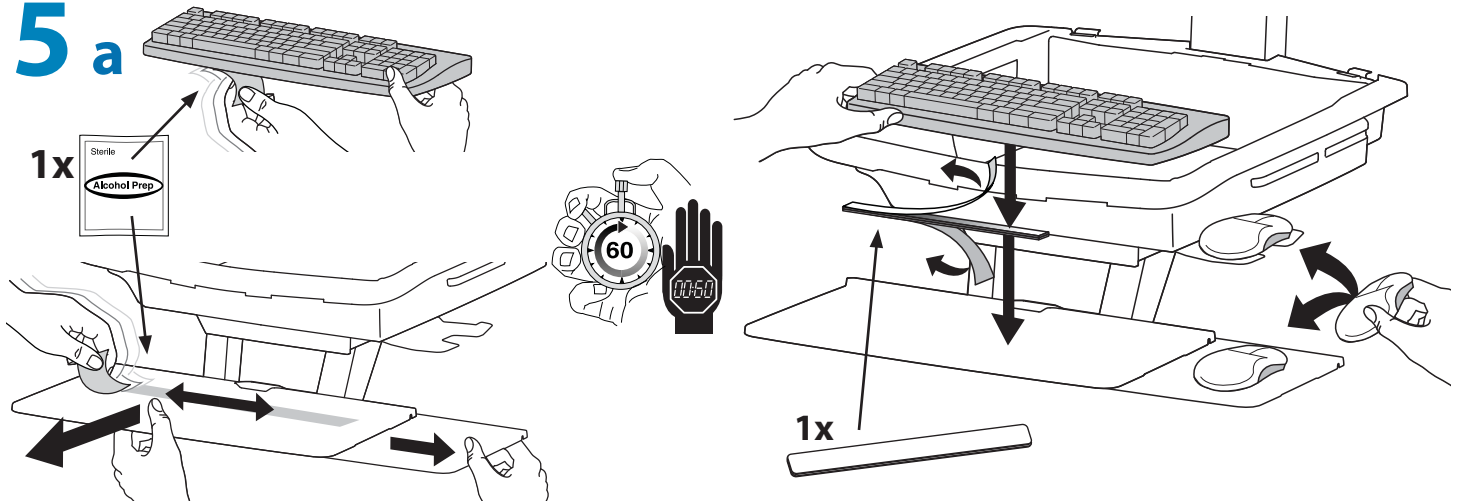

b

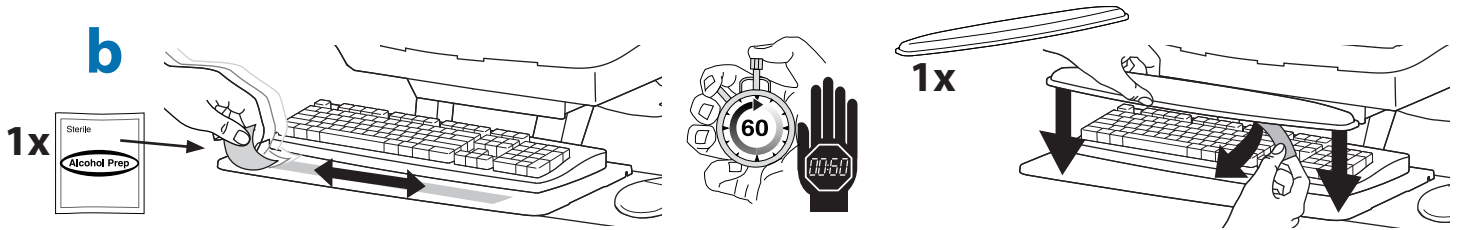

6 a

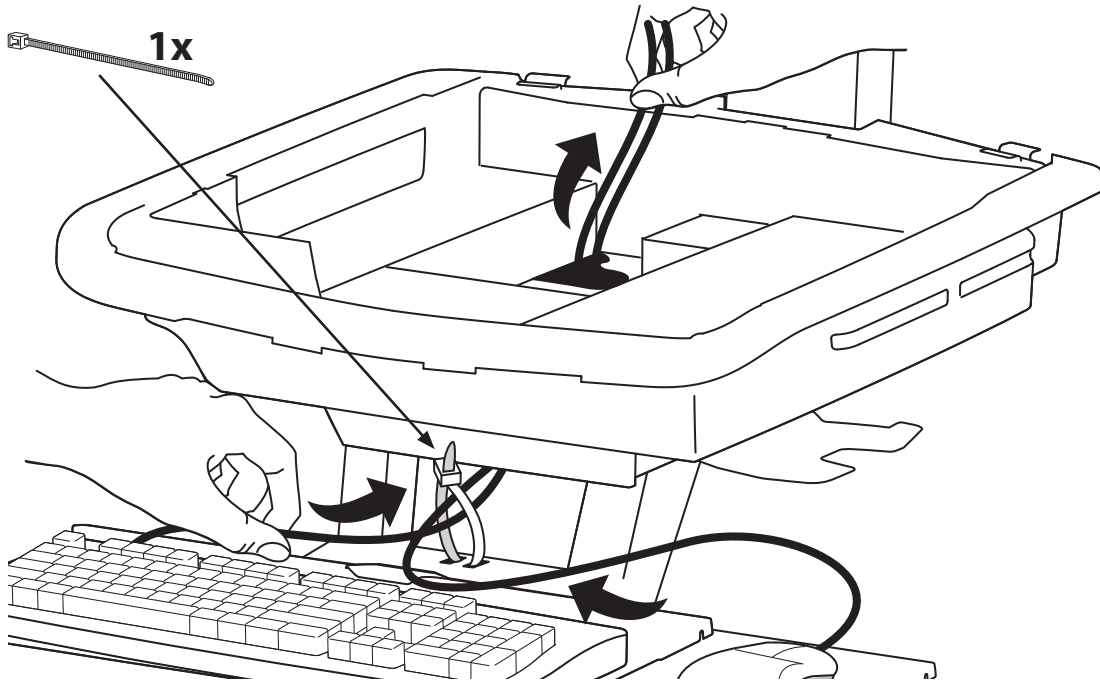

b

Connect Keyboard and Mouse to USB Hub

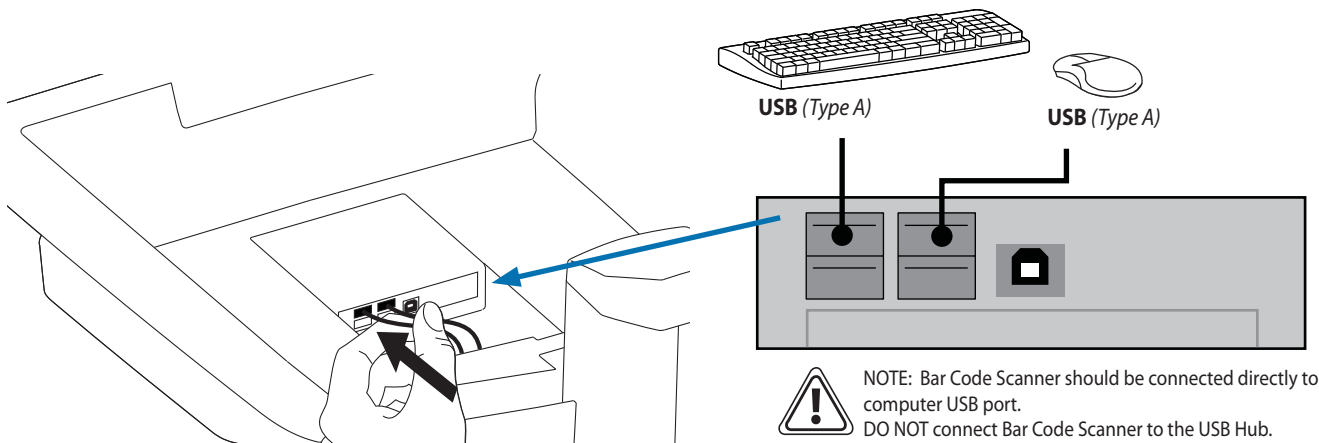

Set-up

7

Set up laptop boosters so the screen fits through the slot in the worksurface and the bottom of the screen is visible when the worksurface is attached.

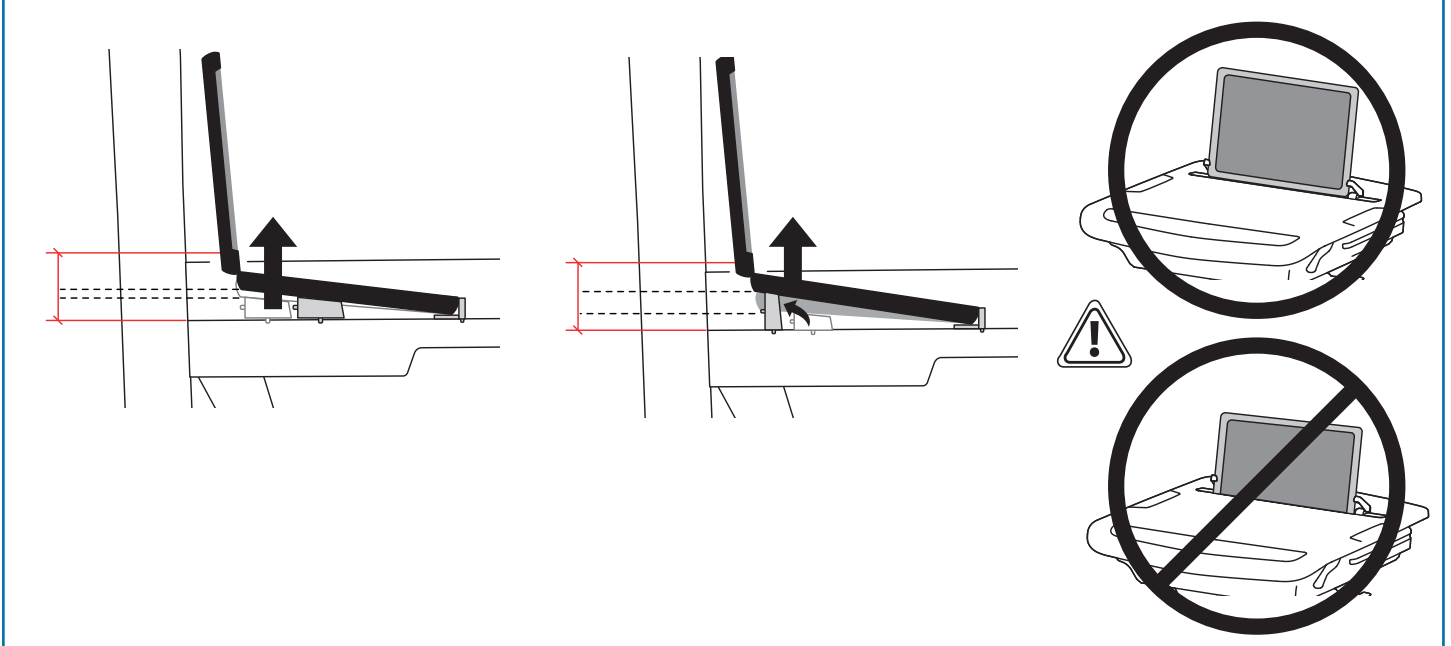
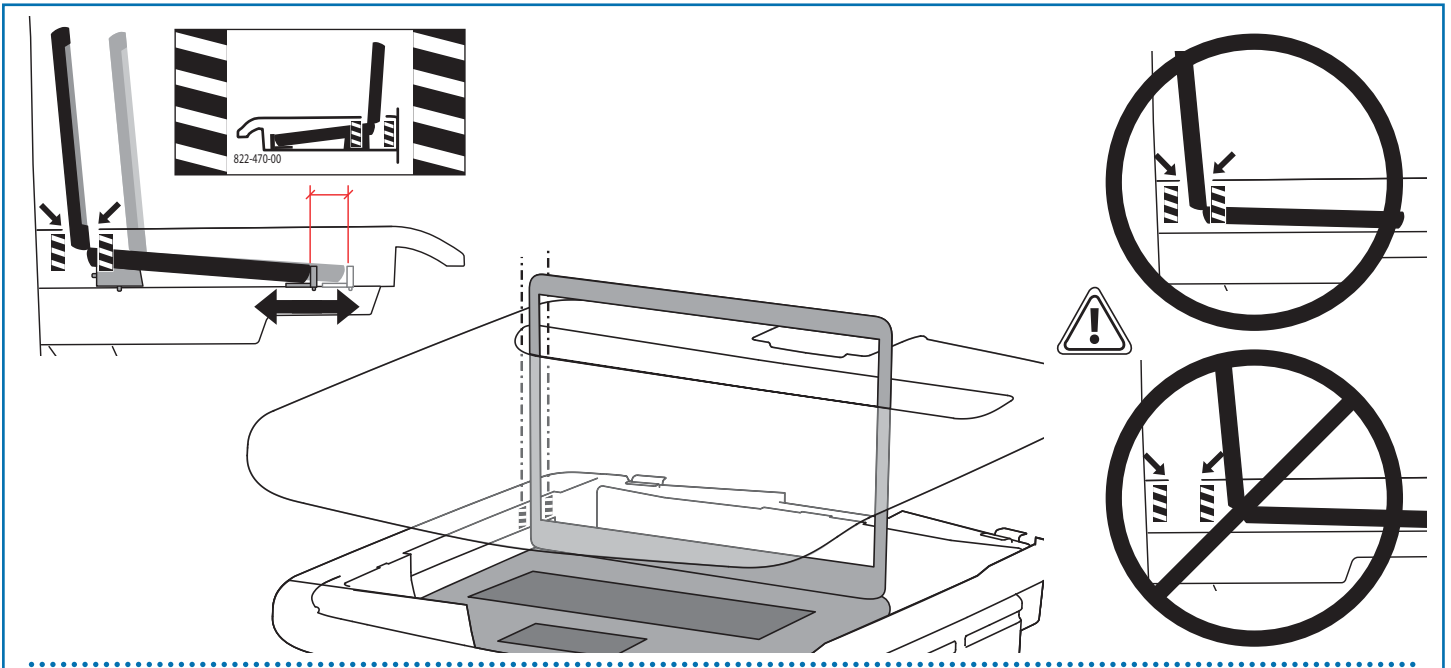
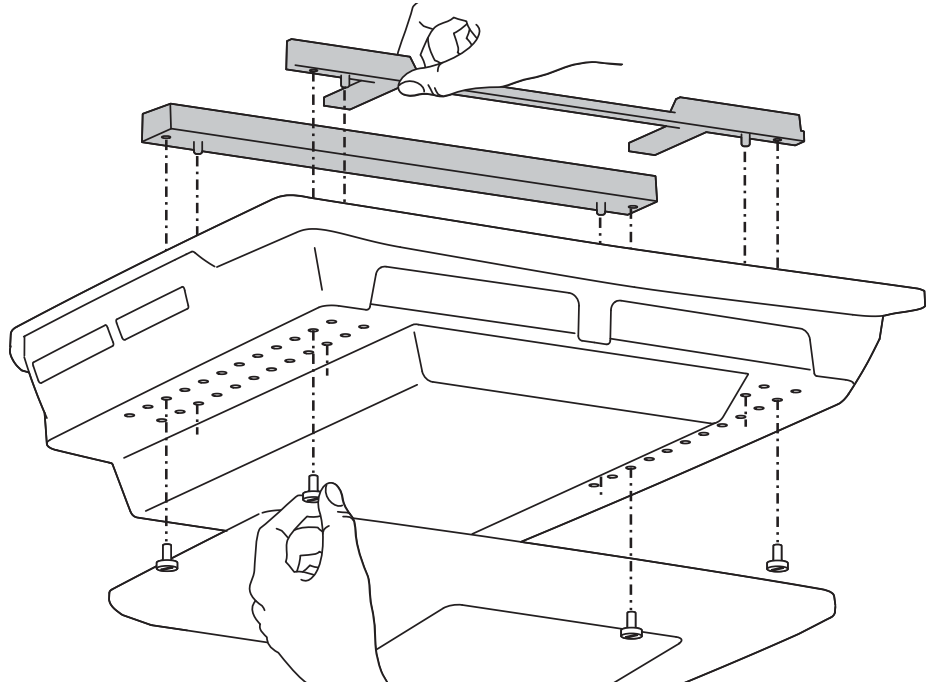
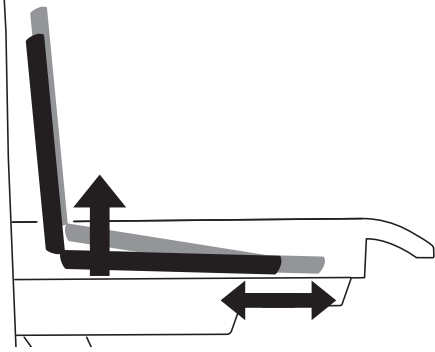

8 a

2x

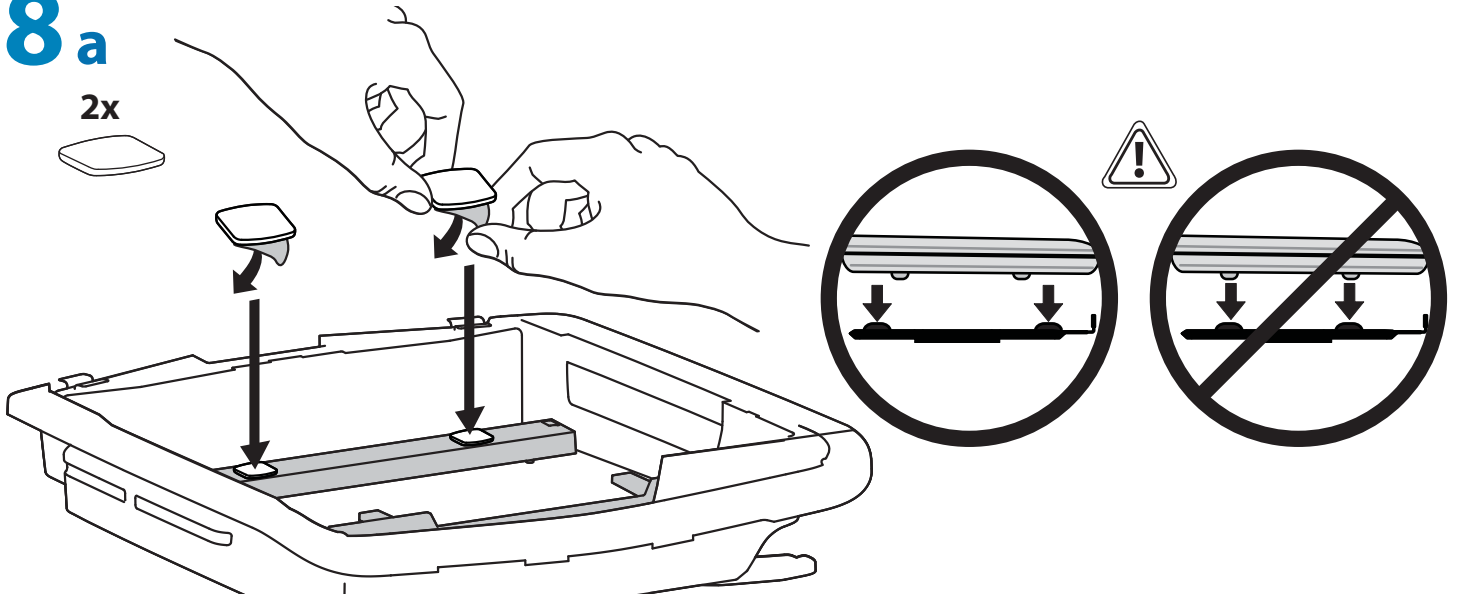

b

Plug the following factory connected cables into your computer.

USB: This cable runs from the USB Hub to your computer and uses your computer to power the USB Hub and Keyboard Lights. (NOTE: Your computer must be turned on for the USB Hub and Keyboard Lights to function).

Optional StyleLink: This USB cable runs from the power system to your computer for StyleLink Software. For more info on StyleLink visit: <http://4support.ergotron.com>.

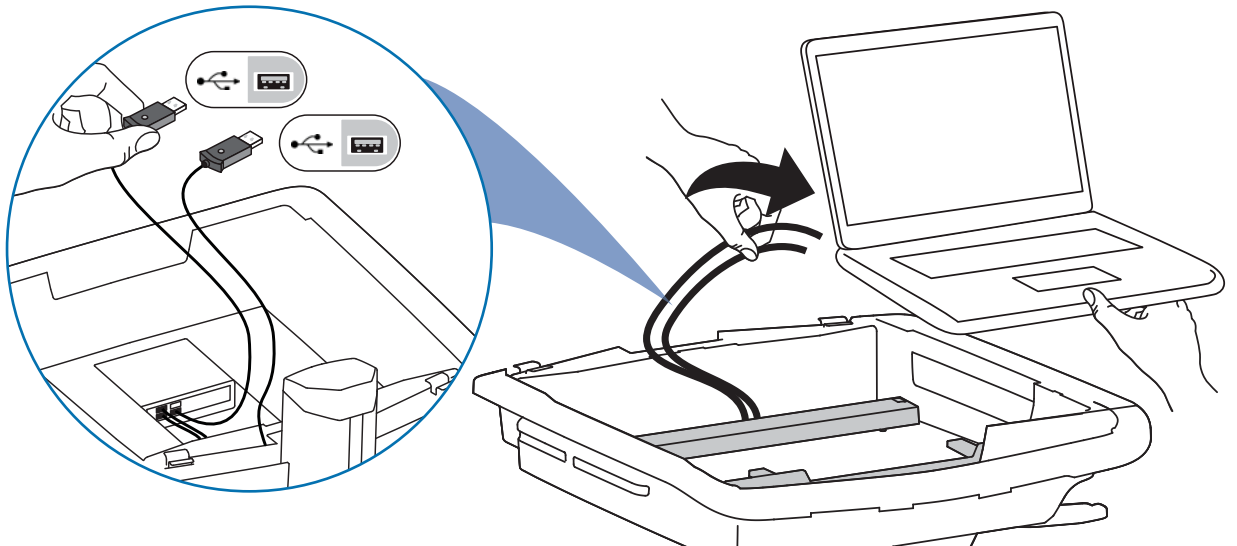

1x

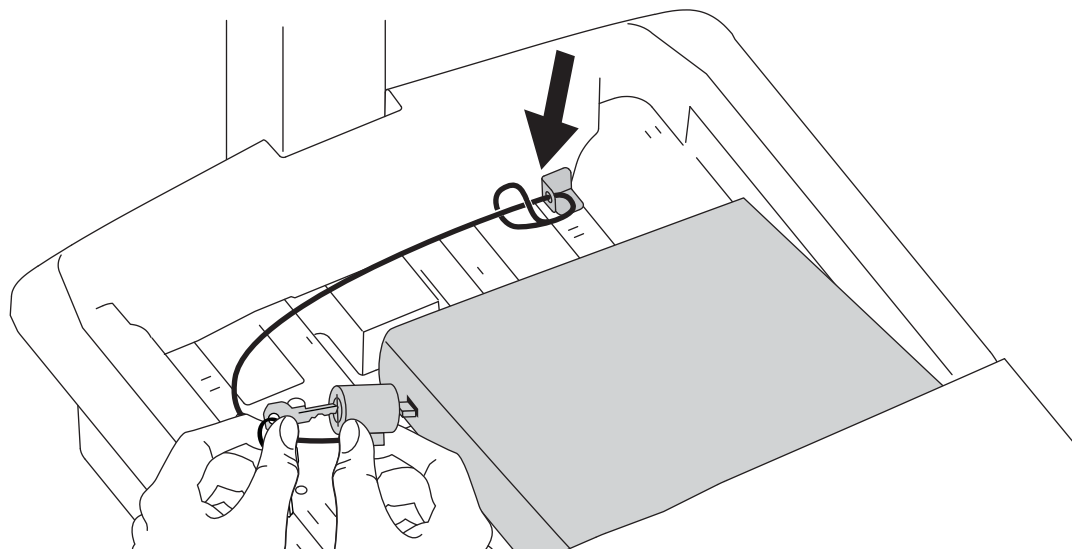

9



DO NOT OBSTRUCT AIR VENTS!
Obstructing air vents may cause overheating and result in equipment damage.

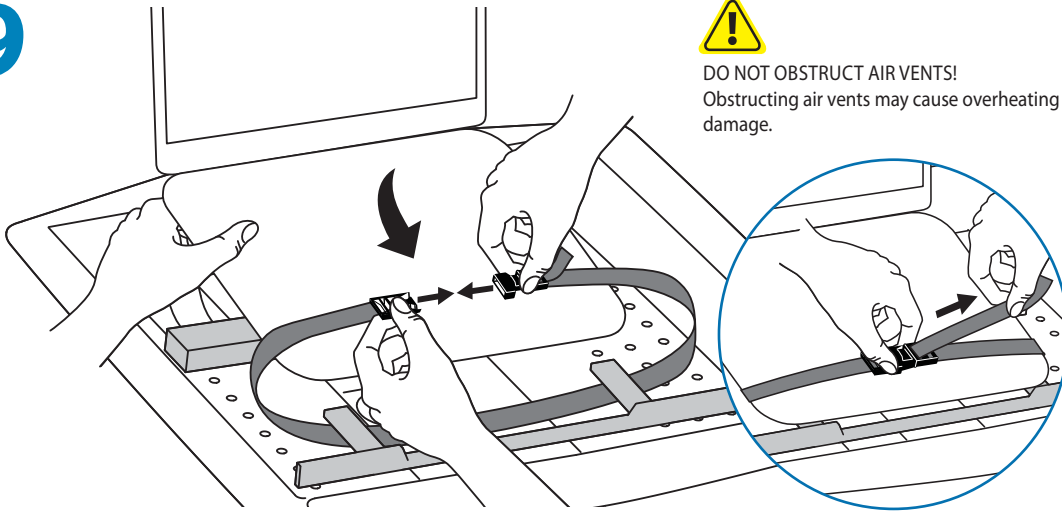

If computer with cables are too wide, then follow these instructions.

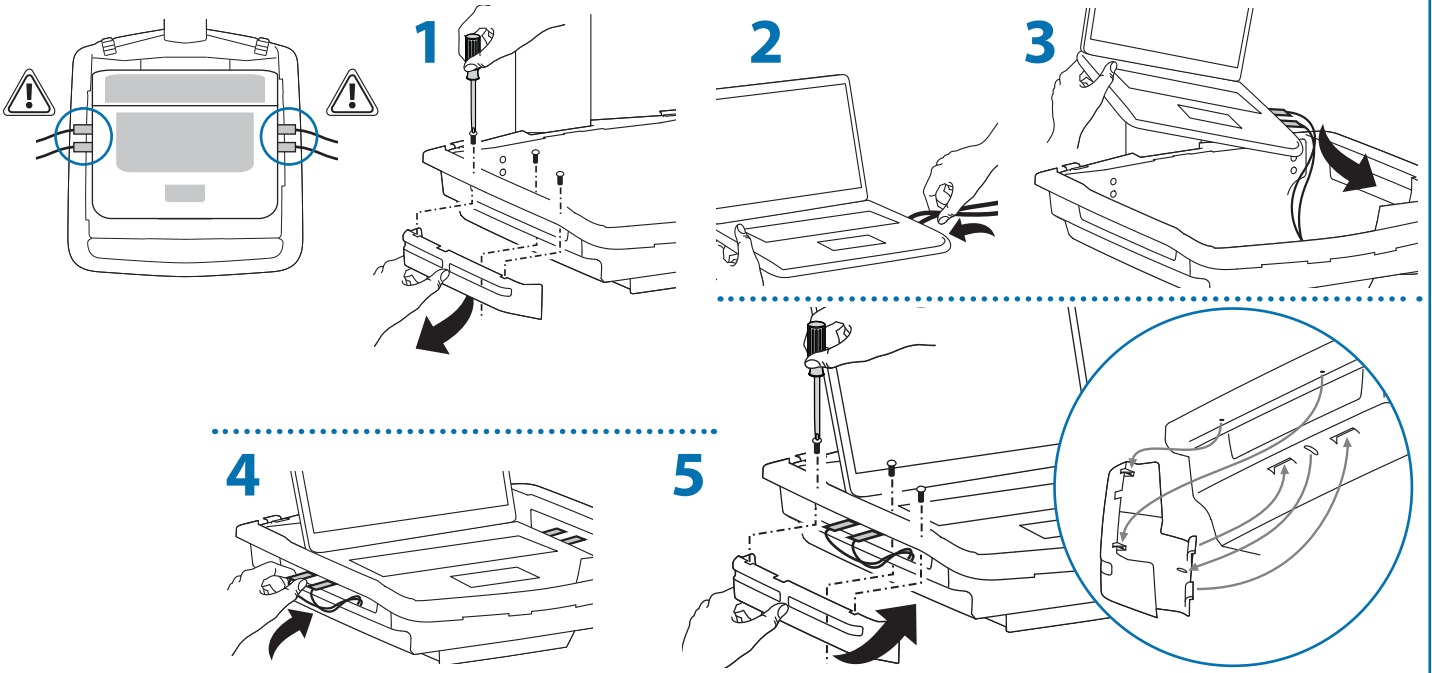

10

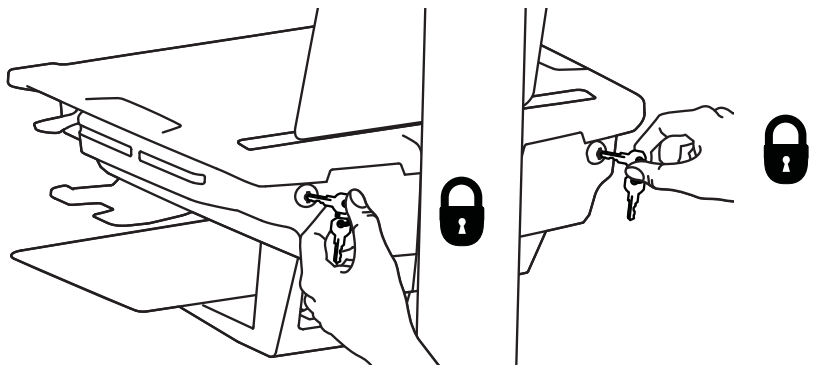
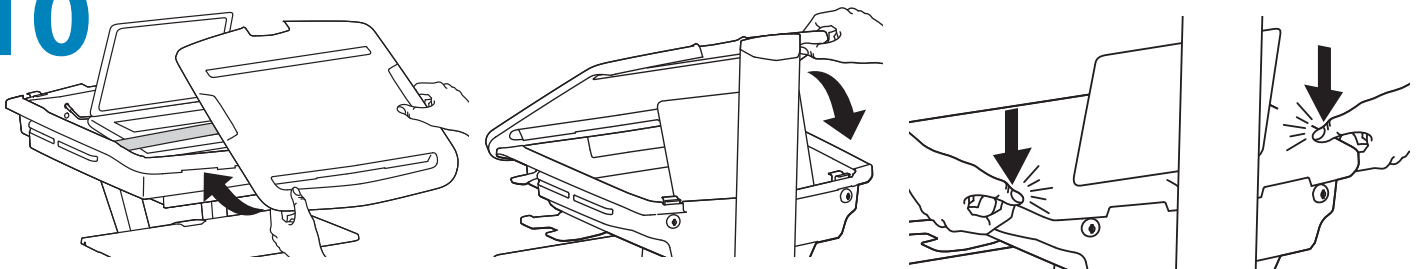

11

1x

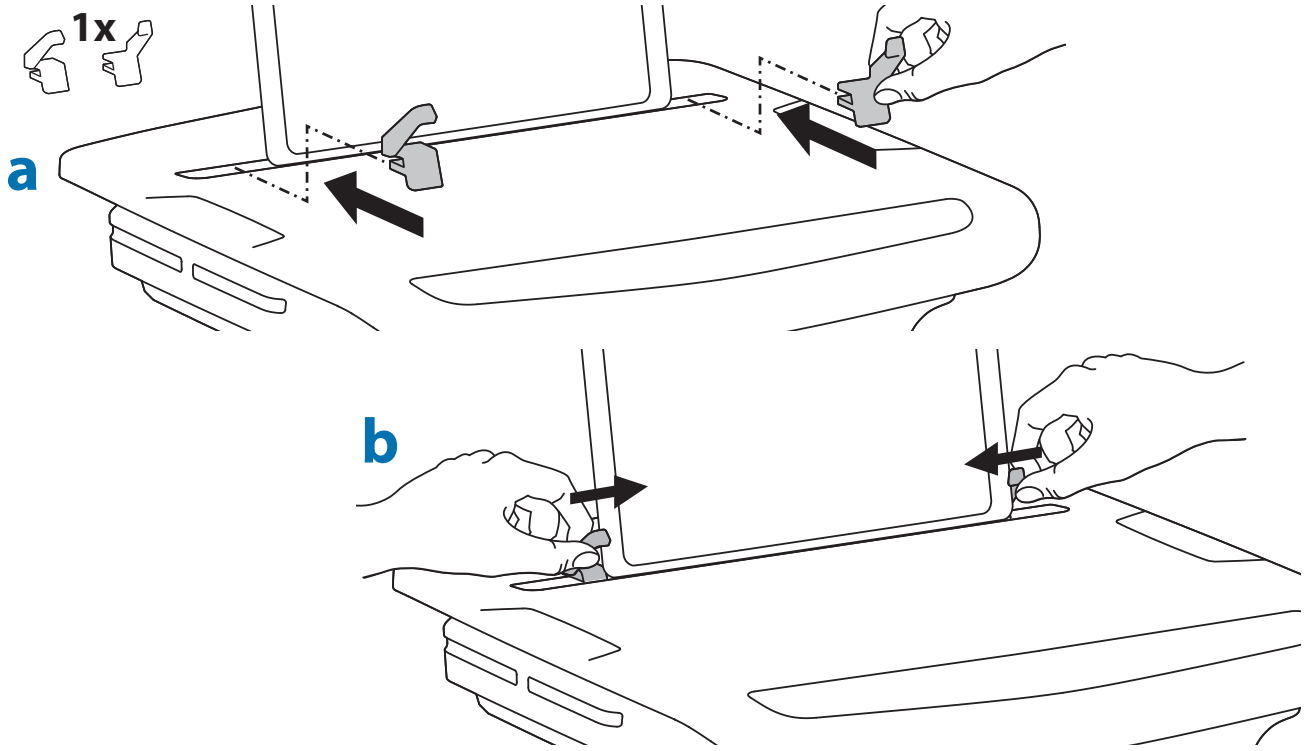

c 1x

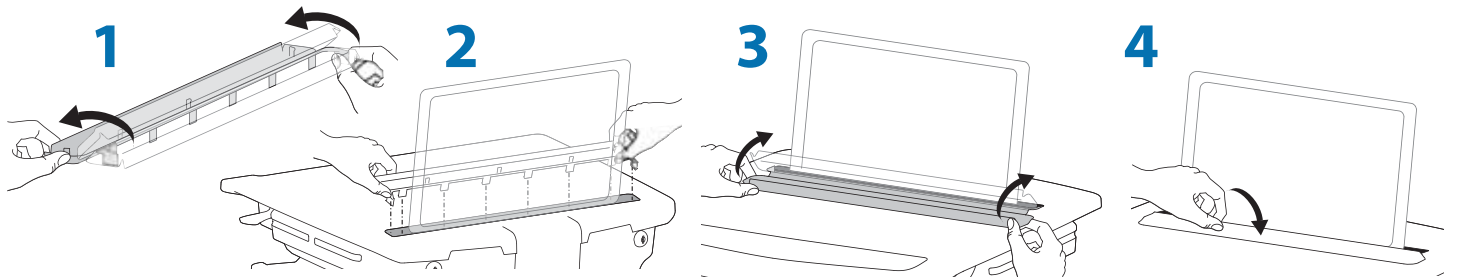

12

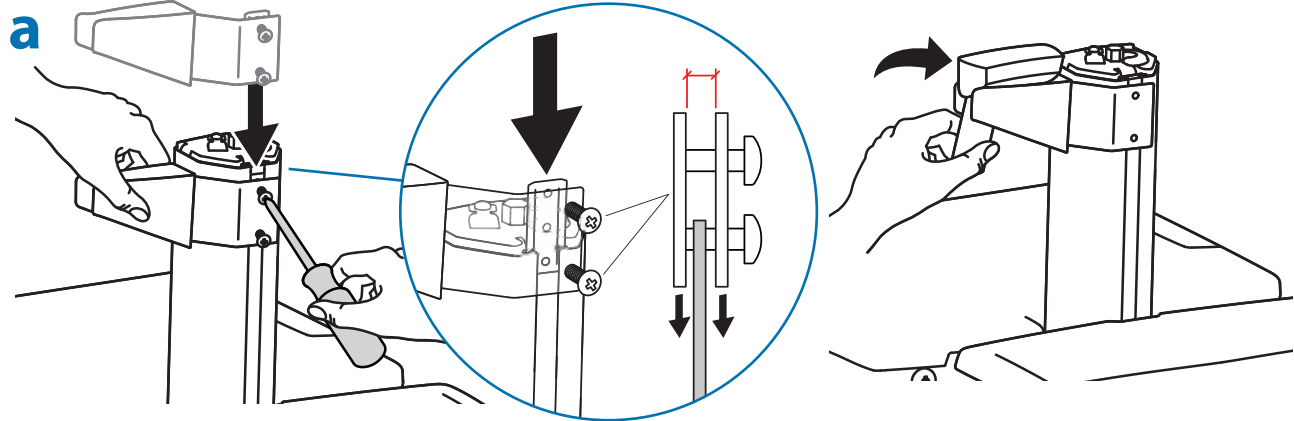

b

1x



1x

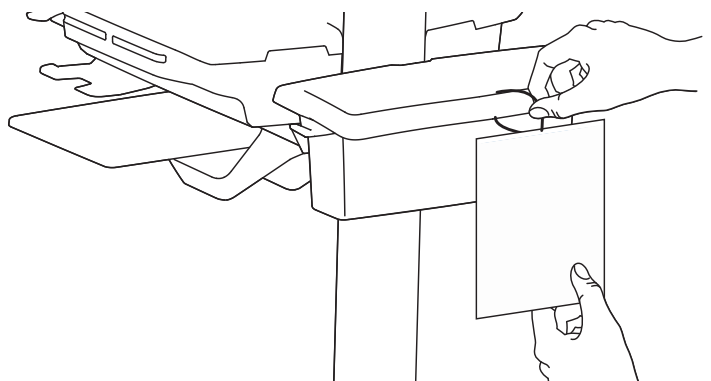

13



It is important that you adjust this product according to the weight of the mounted equipment as described in the following steps. Any time equipment is added or removed from this product, resulting in a change in the weight of the mounted load, you should repeat these adjustment steps to ensure safe and optimum operation. Adjustments should move smoothly and easily through the full range of motion and stay where you set it. If adjustments are difficult and do not stay in the desired position, follow the instructions to loosen or tighten the tension. Depending on your product and the adjustment, it may take several turns to notice a difference.

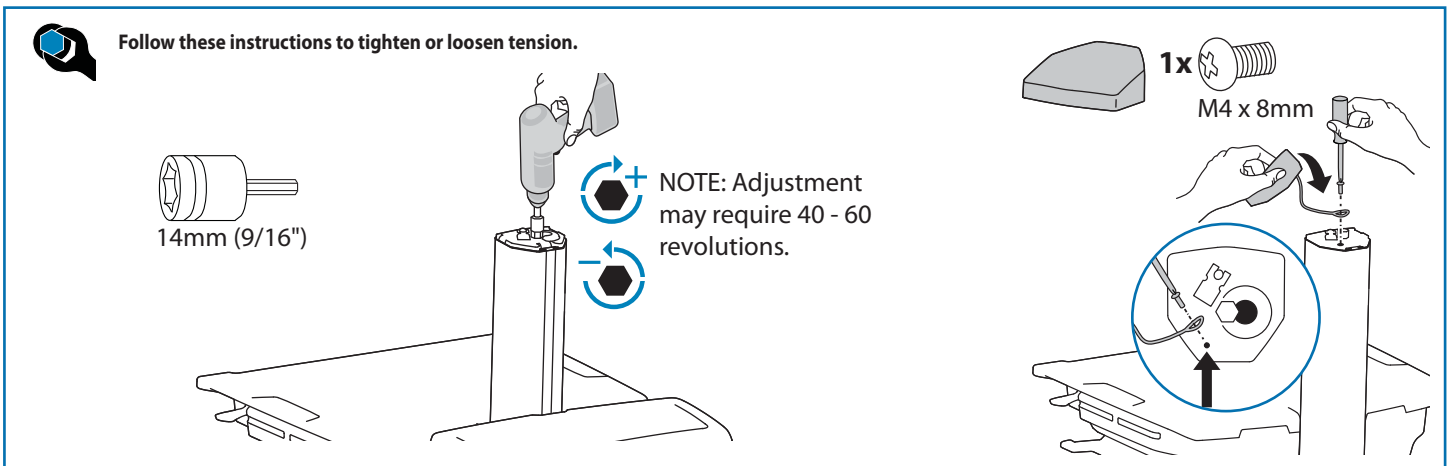
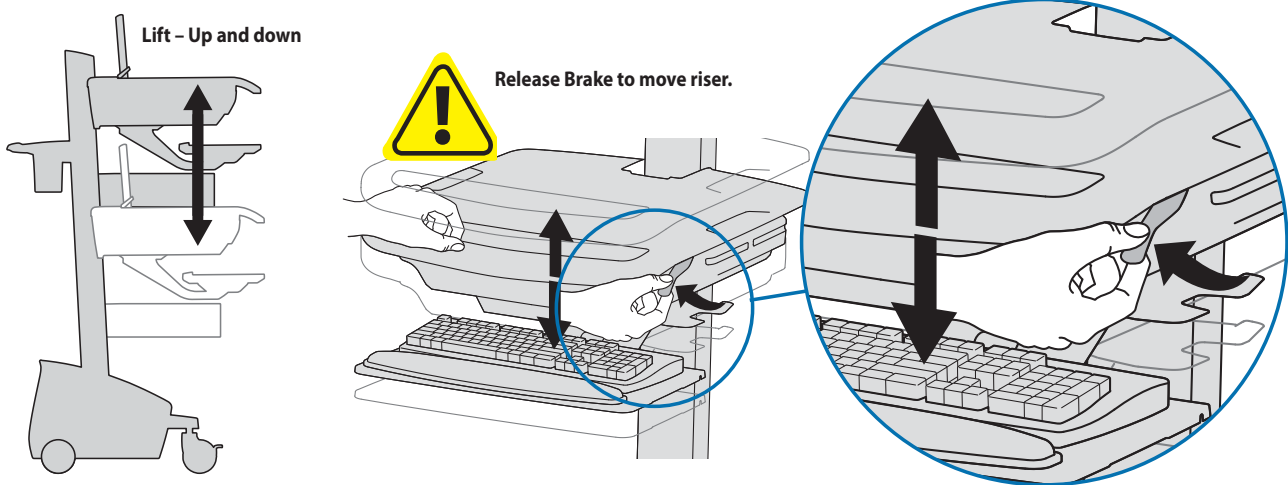

14 Initial Power on/Charge Battery (takes approximately 7 hours to charge)

a Plug Cart's Power Cord into wall outlet.

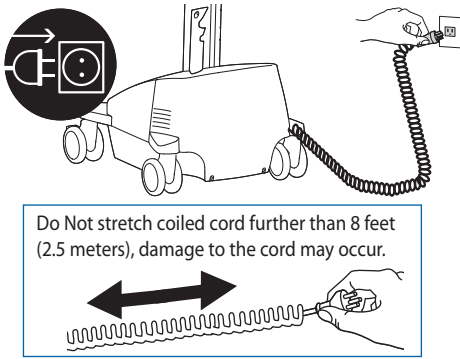

CAUTION: There is no on/off switch on this equipment; the AC power cord is the only power disconnect. The socket outlet should be easily accessible and should be installed near the equipment.

b Turn on power system by holding power button down for 1 - 3 seconds.

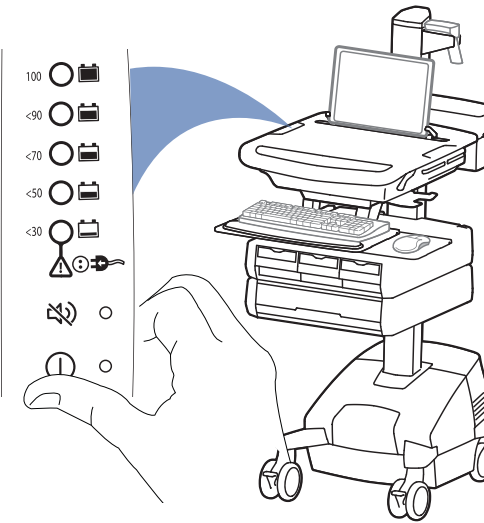

c With cart's power cord plugged into the wall outlet, wait until cart is at 100% charge. (takes approximately up to 7 hours to charge)



This power system interface will alert you to the percentage of charge remaining in the cart battery with a series of steady or flashing red, yellow or green lights, and an alarm that will beep when charge gets below 30%. Remember, the battery needs to be charged to 100% every day, and you can use the cart while charging, so plug-in cord as often as possible to avoid running out of power!
NOTE: Put monitor in power save mode to optimize battery run time.

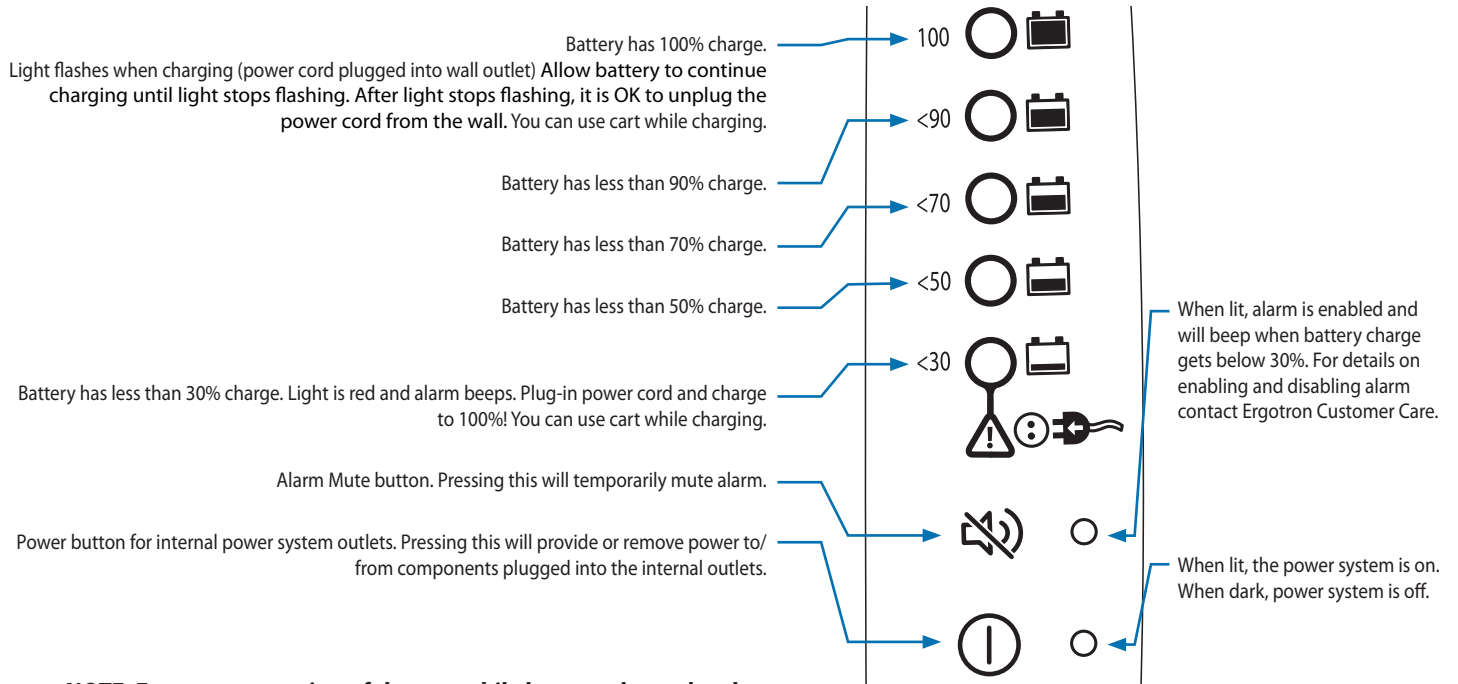

NOTE: Frequent operation of the cart while battery charge levels are below 30% will significantly reduce the life of your battery and may void your battery warranty.

15 Keyboard Light

Keyboard Light will automatically turn off after 15 minutes if not manually turned off.

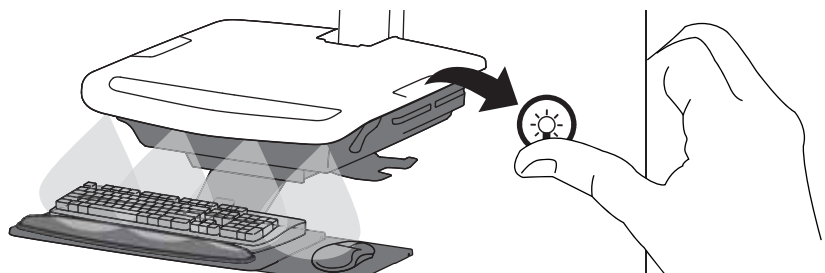

16

NOTE: User should change Master Personal Identification Number (PIN) upon receipt of cart.



Lost Master PIN

Contact Ergotron Customer Care for instructions.

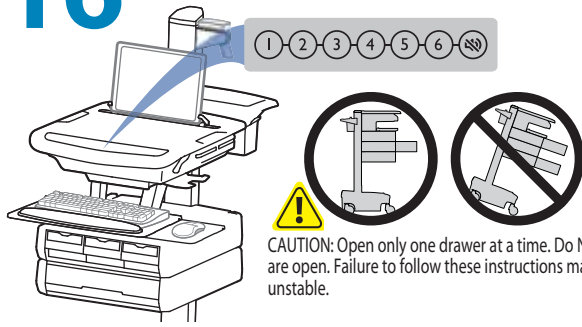

CAUTION: Open only one drawer at a time. Do Not push cart when drawers are open. Failure to follow these instructions may cause the cart to be unstable.

Ensure that the main power system batteries are installed and functioning. The power does not need to be turned on at the power system user interface.

Set-up Master PIN for the First Time (Default Master PIN: 12345)

Contact Ergotron Customer Care for instructions if Master PIN is lost.

1. Enter Master PIN (All numbers associated with available drawers will light).
2. Simultaneously press 3 and 5 (Numbers 3 and 5 will light green).
3. Simultaneously press 3 and 5 again (Numbers 3 and 5 will flash green).
4. Simultaneously press 3 and 5 a third time (All numbers will light green). You have 5 seconds to enter the new Master PIN.
5. Input new 5 digit Master PIN (All numbers will flash green).
6. Wait 5 seconds for system to exit program mode (All numbers will flash green several times).

Programming User PINS

1. Enter Master PIN (All numbers associated with available drawers will light).
2. Simultaneously press 4 and 6 (Numbers 4 and 6 will light green).
3. Simultaneously press 4 and 6 again (Numbers 4 and 6 will flash green).
4. Simultaneously press 4 and 6 a third time (All numbers will light green). You have 10 seconds to enter a new User PIN.
5. Input new 5 digit User PIN (All numbers will flash green). You can continue to enter 5 digit User PINs until finished.

After sitting idle for 10 seconds, system will exit program mode (All numbers will flash green several times).

NOTE: System will hold up to 100 User PINs. Once 100 User PINs storage is exceeded, the oldest User PIN will be overwritten by the next User PIN programmed.

Unlock Drawer (3 methods):

- Enter Master PIN, then press desired drawer number*.
- Enter User PIN, then press desired drawer number*.
- Key - turn clockwise 1/4 turn

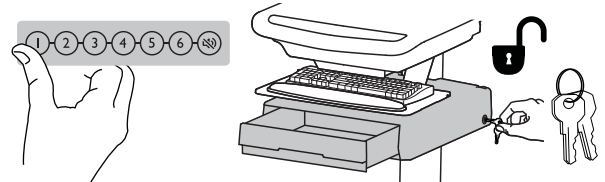

***Drawer Numbers:**

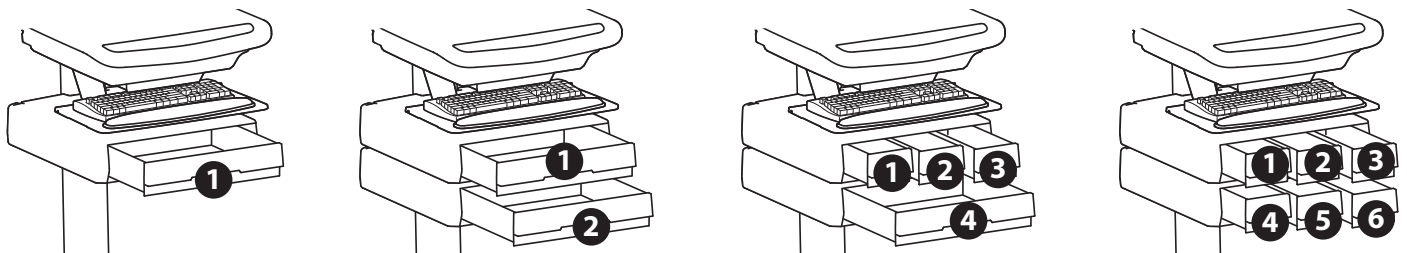

Lock Drawer:

- Wait 4 seconds for lock to engage automatically.

NOTE: Drawer must be fully closed to lock.

Drawer Troubleshooting

• Key pad numbers are dark:

- Touch anywhere on number pad to activate back-light, (drawer remains locked until you enter valid PIN).
- Check to make sure DC cable is connected.

• Drawer won't open when User PIN is entered:

- Test system by entering Master PIN. If drawer doesn't unlock, contact Ergotron customer care for "Lost Master PIN" instructions.

Lights: Meaning

1,2,3,4,5 or 6 and Red mute button

Flashing and alarm sounding: Drawer is open longer than 20 seconds. Mute button can be pressed to mute alarm. System will not function until drawer is shut and locked. The number corresponding to the open drawer will Flash Red on the keypad.

All available drawer numbers

Flashing Green: Waiting for drawer selection (see **Unlock Drawer**)

All available drawer numbers

Flashing Red: Firmware upgrade is happening

All flash once: New code accepted.

All flash three times: Exiting program mode.

How to Change Fuse and Reset Circuit Breakers

1 Turn off all mounted equipment.



2 Disconnect Power System from power source.

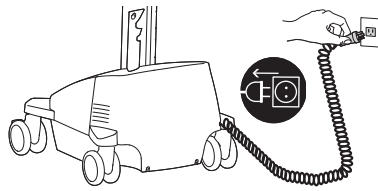

3 Turn power system off by holding down the AC Outlet Power button for 1 - 3 seconds. Power light will shut off.

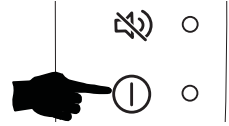

4

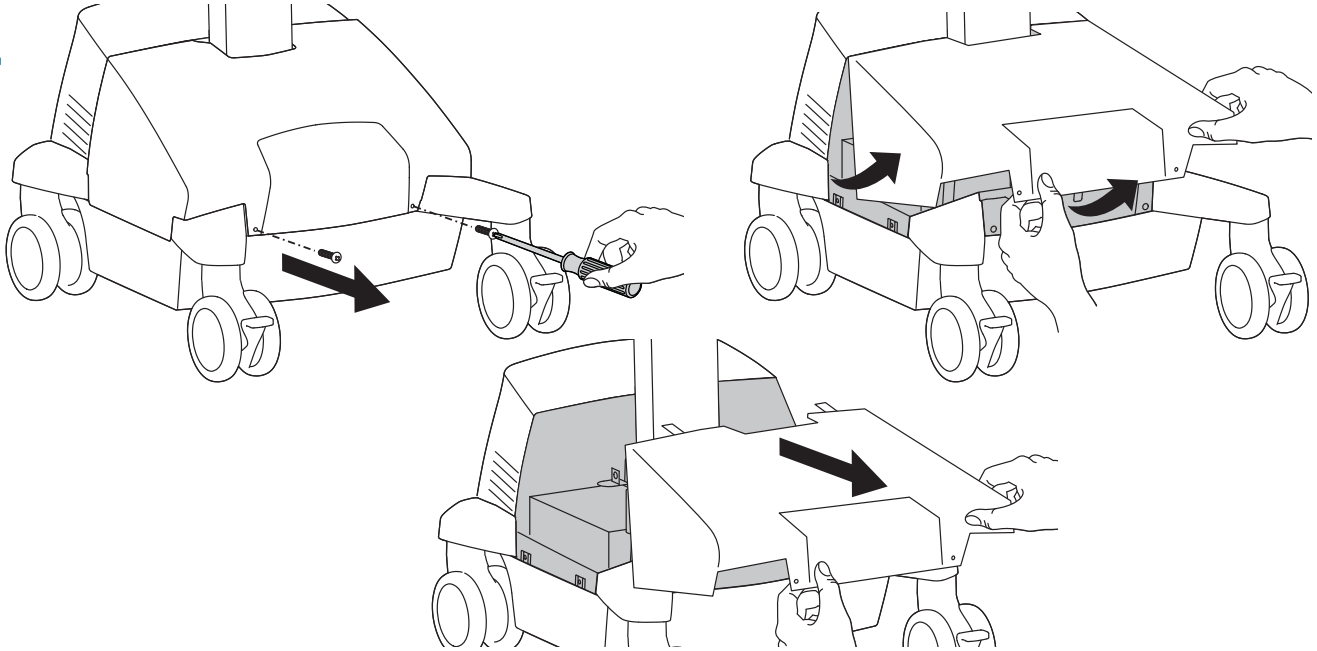

1 Amp Fuse

Recommended:
Littelfuse 312001P

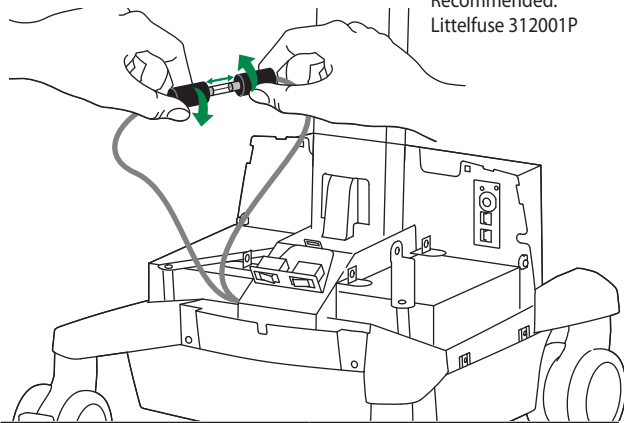

FUSE RATING	
VOLTAGE	250V
CURRENT	1A
OPERATING SPEED	FAST-ACTING
BREAKING CAPACITY	35A @ 250VAC 10000A @ 125VAC

5

Before resetting circuit breakers, contact Ergotron to determine cause of trip.

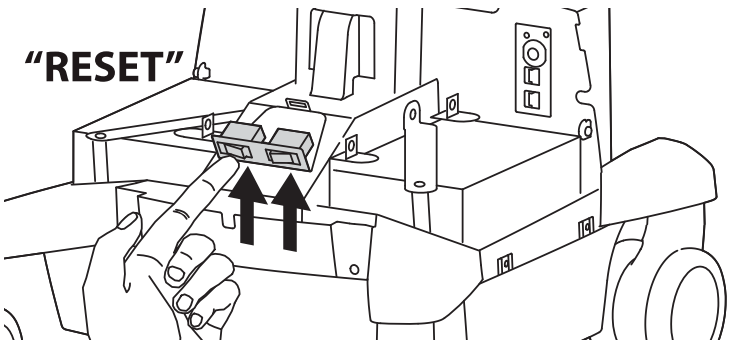

6

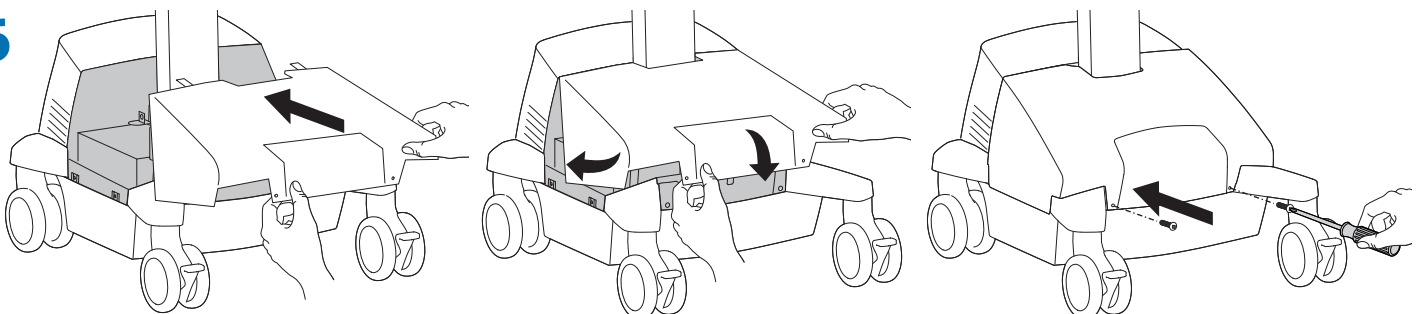

How to Change Power System Batteries

⚠️ WARNING: RISK OF ELECTRICAL DISCHARGE

- Do NOT swap battery cables, doing so will cause arcing and trip the circuit breaker.
- Do not remove or replace the batteries while cart is located in an oxygen rich or hazardous environment, arcing may occur and cause combustion.
- Replace first battery before removing second battery to reduce the risk of cables touching terminals and causing arcing.



- Always replace both batteries!
- Replace first battery before removing second battery.
- Replace batteries with same Amp/Hour rating batteries only.
- Only Ergotron-specified batteries may be used in the StyleView Power System. Please call customer care for more details.
- Recycle battery or contact Ergotron for proper battery disposal guidelines.

⚠️ WARNING

IMPORTANT REPLACEMENT BATTERY INFORMATION

The power module is configured for two, 33-Ah batteries. Only the following batteries are compatible with this system:

- B&B EP33-12
- SBS S-12330
- Longway 6FM33G
- Vision 6FM33D
- PBQ PBQ33-12L
- Werker WKA12-33C • Werker WKA12-35C

Installing batteries other than the 33-Ah listed above will void the product warranty. Failure to heed this warning may result in severe damage to batteries, power module and possible fire hazard. Contact Ergotron for more information at 1-800-888-8458.

822-386

1 a Turn off all mounted equipment.



b Disconnect Power System from power source.

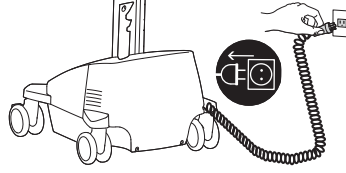

c Turn power system off by holding down the AC Outlet Power button for 1 - 3 seconds. Power light will shut off.

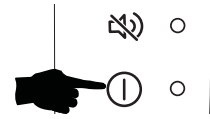

2 a

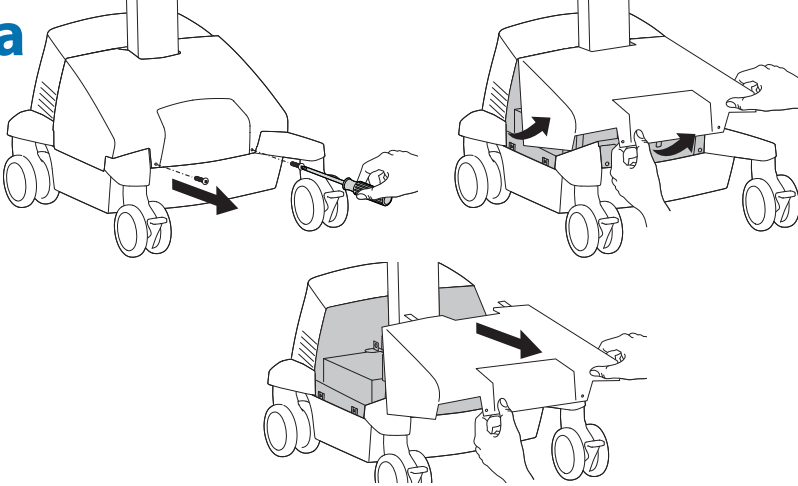

b Turn both circuit breakers to "OFF".

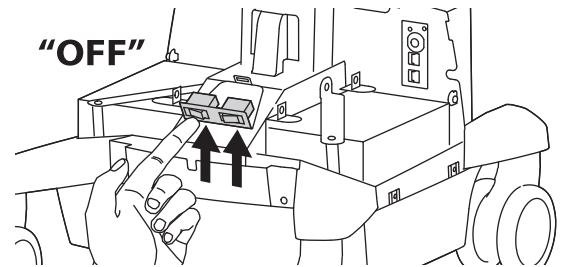

3 ⚠️ Caution: Do NOT swap battery cables, doing so will cause sparking and trip the circuit breaker.

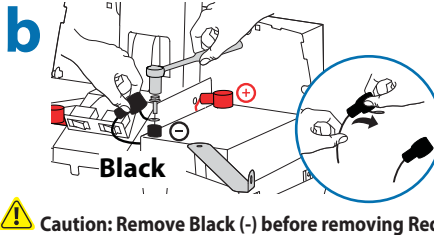
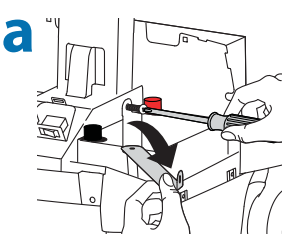
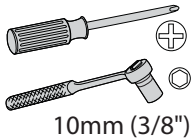

⚠️ Caution: Remove Black (-) before removing Red (+).

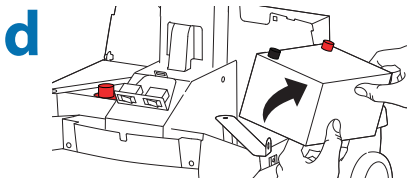
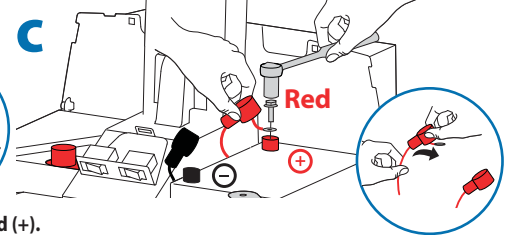

Recycle battery or contact Ergotron for proper battery disposal guidelines.

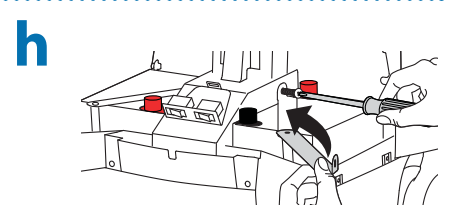
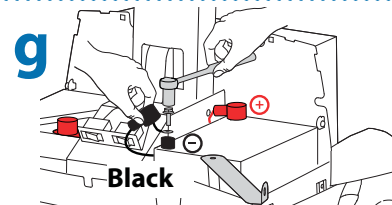
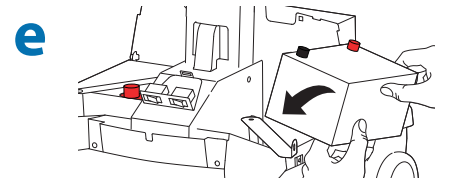

⚠️ Caution: Connect Red (+) before connecting Black (-).

How to Change Power System Batteries

4 ⚠️ Caution: Do NOT swap battery cables, doing so will cause sparking and trip the circuit breaker.

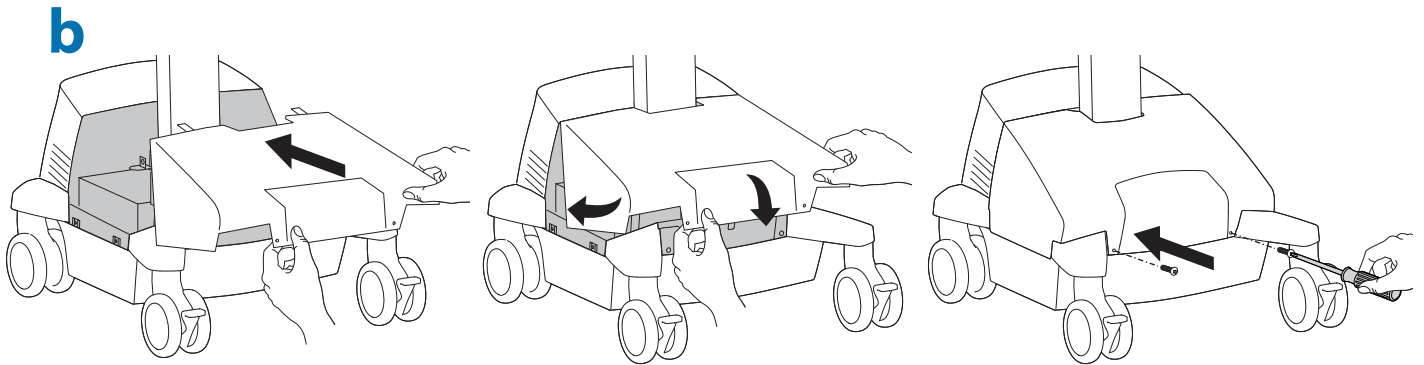
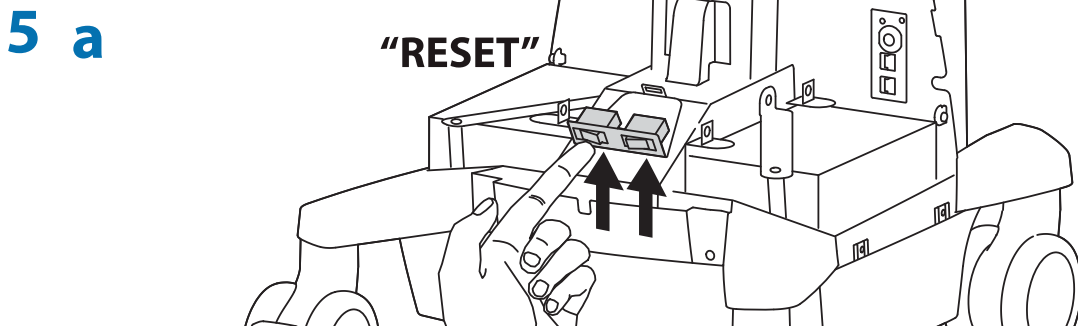
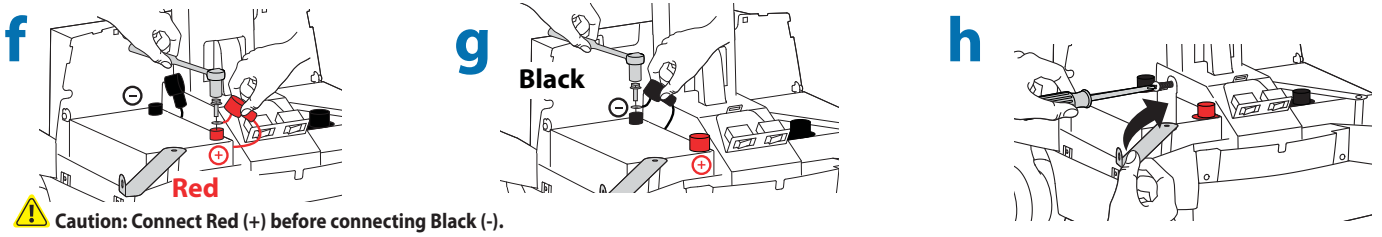
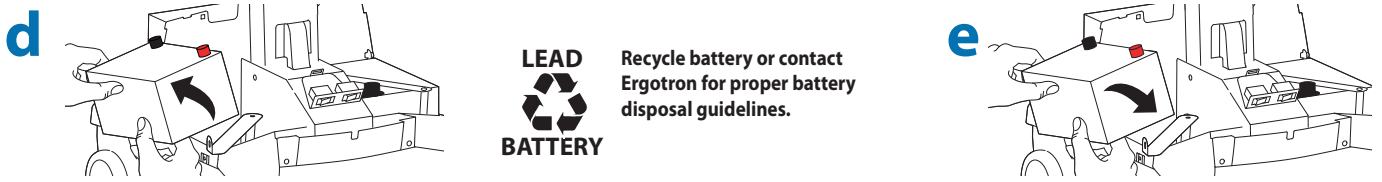
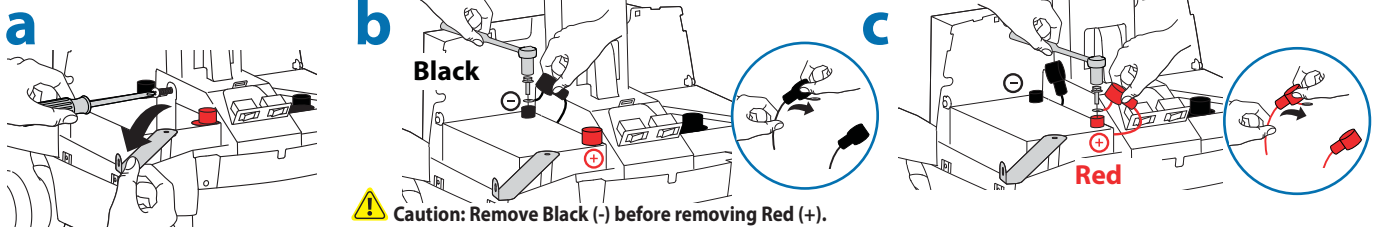

6 Follow Battery Charge/Discharge Initial Power On steps a, b, c.

Cart Storage Instructions

Short Term Storage - If the Power System will be idle for up to 3 months, the battery should be fully charged before storage.

Long Term Storage - If the Power System will be idle for 3 months or more, the battery should be removed from the cart and recharged during storage.

Short Term Storage - If the Power System will be idle for up to 3 months, the battery should be fully charged before storage.

1 Turn off all mounted equipment.



2 Plug power cord into appropriate wall outlet to fully charge battery to 100% (all indicator lights will be illuminated). Power system must be fully charged before storing!

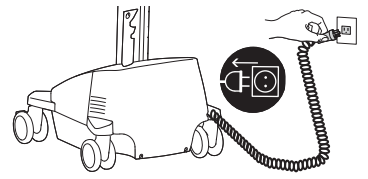

3 Once battery has been charged to 100%, turn power system off.
a. Turn power system off by holding down the AC Outlet Power button for 1 - 3 seconds. Power light will shut off.
b. Turn both circuit breakers to "OFF".

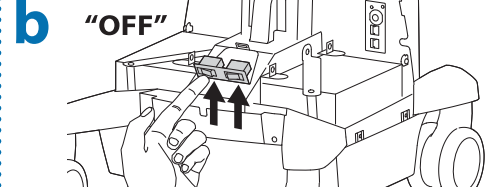
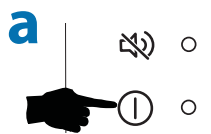

NOTICE:

Warranty on fully charged batteries left in an unused state for more than three (3) consecutive months is automatically void.
 Warranty on fully discharged batteries left in an unused state for more than three (3) consecutive days is automatically void.

Long Term Storage - If the Power System will be idle for 3 months or more, the battery should be removed from the cart and recharged during storage.

WARNING: Do not remove or replace the batteries while cart is located in an oxygen rich or hazardous environment. Sparking may occur.

1 Turn off all mounted equipment.



2 Disconnect Power System from power source.

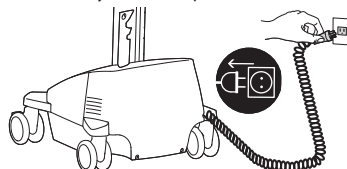

3 Turn power system off by holding down the AC Outlet Power button for 1 - 3 seconds. Power light will shut off.



4

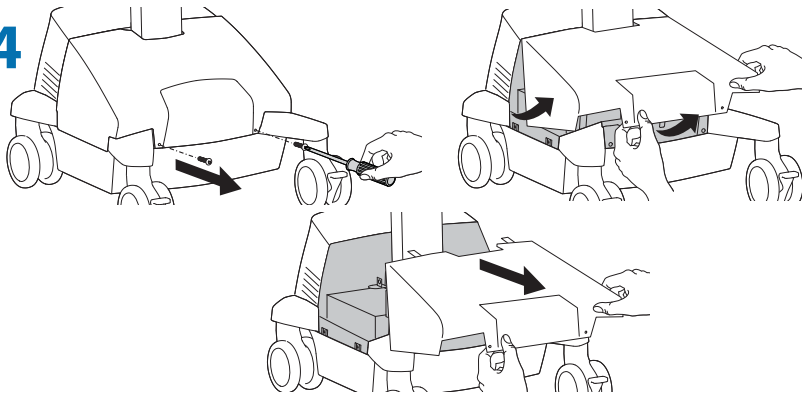

5 Turn both circuit breakers to "OFF".

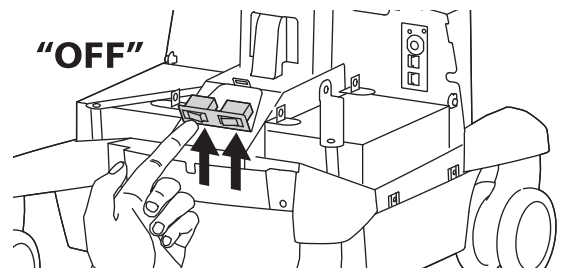

Caution: Remove Black (-) before removing Red (+).

6

Black

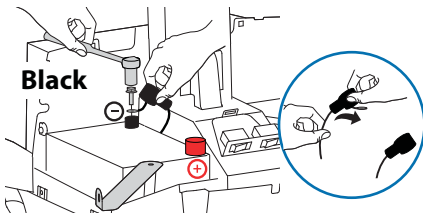

7

Red

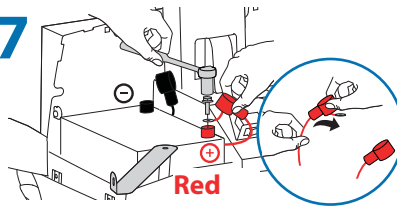

8

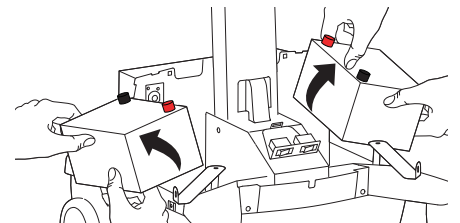

9 Store battery in cool, dry area while Cart is out of use. Optimal storage temperature is 15°C/59°F. Battery voltage should be checked every three (3) months. If voltage drops below 12.5VDC, fully recharge battery. Contact Ergotron Customer Care for information about how storage might impact the battery warranty.

10

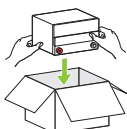
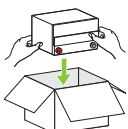
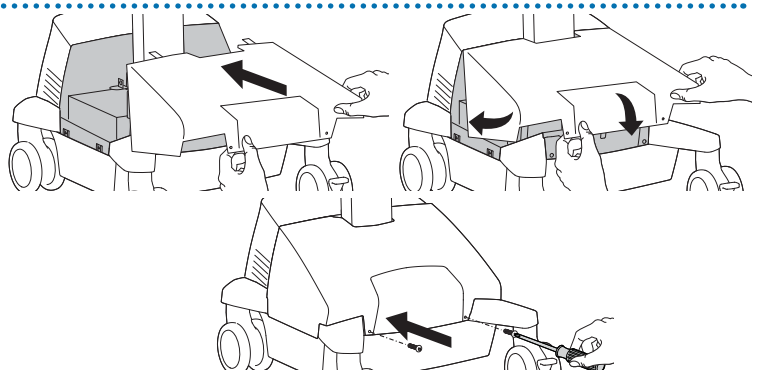

Ergonomics

Working

customize - to your size

- 1 Set top of monitor screen about one inch below eye level - Release brake and lift or lower riser as needed.
- 2 Tilt screen for comfortable viewing and to reduce eye and neck strain.
- 3 Pull keyboard tray forward and position mouse tray on right or left, as needed.
- 4 Work with elbows bent at about 90° to minimize muscle strain.
- 5 If the riser moves up and down with difficulty, or if it drifts out of set position, consult the product manual for adjustment information.
- 6 Stay in charge!
Powered carts should be plugged into outlet as often as possible to keep battery charged and computer running.

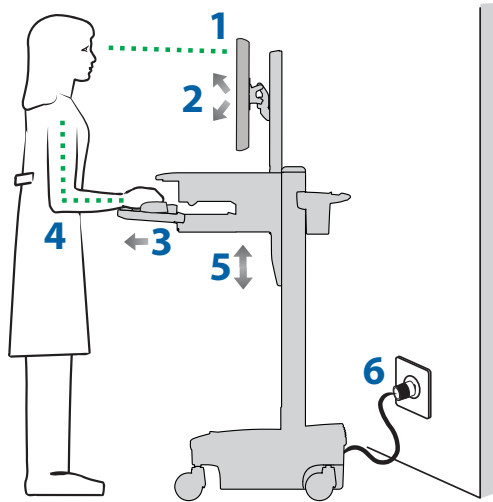

Moving

stow - before you go

- 1 During normal movement, release brake and lower worksurface to lowest position for optimal stability and unobstructed view.
- 2 Tuck away open trays and return mouse, scanner and other accessories to their places.
- 3 Unlock both front casters.
- 4 Push cart from rear with elbows bent at about 90° to maximize control and minimize muscle strain.
- 5 Don't run out!
Before moving, make sure cord is unplugged from outlet and hooked to basket for safe travel. Remember, charge battery fully 100% every day!

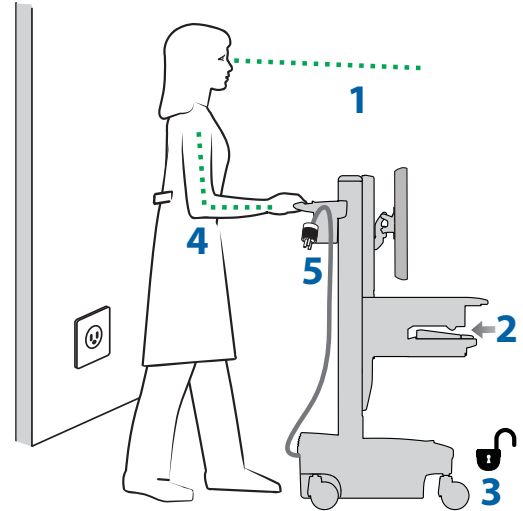

Maintenance & Safety

Hazard Symbols Review

The Meaning of Symbols appearing in this Guide, on the Cart or on the Power System

These symbols alert you to a safety condition that demands your attention. You should be able to recognize and understand the significance of the following Safety Hazards if you encounter them on the Cart or within Cart documentation such as this Set-up Guide.

Symbol	Signal Word/ Color	Level of Hazard
	DANGER	Indicates an imminently hazardous situation which, if not avoided, will result in death or serious injury.
	WARNING	Indicates a potentially hazardous situation which, if not avoided, could result in death or serious injury.
	CAUTION	Indicates a potentially hazardous situation which, if not avoided, may result in minor or moderate injury.
	CAUTION	Used without the safety alert symbol indicates a potentially hazardous situation which, if not avoided, may result in property damage.
	INSTRUCTIONS	Follow operating instructions.
	INSTRUCTIONS	Follow operating instructions.
	POWER	"ON" / "OFF" (push-push) NOTE: Each position "ON" / "OFF" is a stable position.



EQUIPMENT & ACCESSORIES DISPOSAL

1. Please dispose of all batteries in accordance with local law
2. All Electronics should be recycled through an electronics recycler.
3. Remaining plastics and metals can be recycled through a commercial recycler.

Maintenance & Safety

Cleaning and Maintenance

The following procedures are not guaranteed to control infection. The hospital infection control administrator or epidemiologist should be consulted regarding cleaning procedures and processes.

 To avoid risk of electric shock, do not expose electrical components to water, cleaning solutions or other potentially corrosive liquids or substances.

 Do not immerse Cart or Cart components in liquid or allow liquids to flow into the Cart. Wipe all cleaners off surface immediately using a damp cloth. Thoroughly dry surface after cleaning.

 Do not use flammable cleaners on Cart surfaces due to close proximity of electrical power and equipment.

All paints and plastic Cart components will withstand cleaning by most commonly used, diluted, non-abrasive solutions such as quaternary ammonia compounds, ammonia enzyme cleaners, bleach or alcohol solutions.

- Pen and permanent and dry erase markers can be removed with 91% isopropyl alcohol and a soft cloth.
 - Iodine stains can be removed with commonly used cleaners and a soft cloth.
 - Never use steel wool or other abrasive materials that will damage the surface finish.
 - Do not use strong solvents such as trichloroethylene and acetone. These solvents will damage the surface finish.
- It is recommended that any cleaning solution be tested on a small, inconspicuous area to ensure surface is not harmed.

 Adjustment, Service, Replacement - DO NOT attempt to adjust, service or replace any part of the StyleView Cart unless directed to do so through Ergotron-approved documentation (i.e. installation instructions). Only Ergotron, Inc. or an Ergotron-certified entity may adjust, service or replace StyleView Cart components. If any component on the Cart is missing or damaged, the Cart must not be used, contact Ergotron Customer Care immediately to request a replacement part.

 Cables - Keep cables neatly organized on the Cart (a variety of solutions are provided with your cart for this purpose). Excess cables should be routed away from moving components with cable clips. Review Cable Routing section of this guide, or contact Ergotron Customer Care for more information.

 Casters - Check casters periodically to make sure they are clean and free of debris that would prevent smooth travel. Avoid moving Cart across uneven, dirty or damaged surfaces.

 Customer Equipment- Make sure equipment is balanced and mounted securely to Cart. Do not reposition Cart components on riser or tower unless instructed to do so in the installation instructions. Moving Cart components too high or too low on the Riser may create an unstable condition, leading to equipment damage or even personal injury. Contact Ergotron Customer Care for information about moving Cart components.

Safety Alerts Associated with this Product

The following Warnings/Cautions appear in this reference guide or on the cart:

NOTE: Failure to adhere to these guidelines may result in equipment damage or personal injury.

 CAUTION: The lift brake helps stabilize the worksurface and keyboard tray during normal use but it DOES NOT increase load capacity. DO NOT load riser with equipment totaling more than the maximum weight capacity specified by Ergotron. Ensure optimum lift function by testing and if necessary, re-adjusting tension whenever the weight mounted to the riser changes (i.e., equipment is removed or added). See "Set Riser Lift Tension" adjustment instructions.

 CAUTION: Do not operate StyleView Cart with missing or damaged components! Do not remove, modify or substitute Cart components without consulting Ergotron. If you encounter problems with Cart installation or operation, contact Ergotron Customer Care.

 CAUTION: DO NOT overtighten fasteners. Overtightening may cause damage to your equipment.

 WARNING: Stored Energy Hazard: The worksurface lift mechanism is under tension and will move up rapidly, on its own, as soon as attached equipment is removed. For this reason, DO NOT remove equipment unless the worksurface has been moved to the highest position on the tower! Failure to follow this instruction may result in serious personal injury and/or equipment damage! When Shipping the cart, set the worksurface lift mechanism to the lowest tension setting.

 CAUTION: DO NOT loosen, tighten or remove any other nuts or bolts on the riser or top of tower. Tampering with nuts or bolts may result in an unstable Cart, leading to equipment damage and/or personal injury.

 CAUTION: Release Lift Brake before moving work surface! Moving work surface while Lift Brake is engaged may cause serious damage to Lift Engine.

 WARNING: In the event that repair of the StyleView Cart is needed, contact Ergotron Customer Care immediately. Cart repair can only be performed by Ergotron, Inc. or by an Ergotron authorized agent.

 WARNING: This cart is not intended for use in a flammable, anesthetic mixture or oxygen rich environment.

Configuration & Safety

 Additional multiple socket-outlet or extension cord shall not be connected to the medical system.

 When used in a Medical Electrical system, connect only equipment that complies with IEC, ISO, UL/ANSI, or CSA standards that are relevant to that equipment.

 Risk of shock or personal injury when connecting non-medical equipment supplied as part of a system directly to the wall outlet when non-medical equipment is intended to be supplied by the multiple socket outlet.

 Risk of shock or personal injury when connecting any equipment that has not been supplied as part of the medical system to the multiple socket outlet.

Maintenance & Safety

Recommended Periodic Inspection and Maintenance			
Component	Action	How often	By whom
UI, Ethernet, USB cables	Inspect for wear, pinching, bad connectors	Monthly	Any user
Casters	Inspect for wear and debris	Monthly	Any user
Maximum Load	Inspect to ensure that maximum recommended loads are not exceeded	Daily	Any user
Power System SLA batteries	Replace lead acid batteries ^{1,2}	When instructed by StyleLink or when battery runtime is 80% of original runtime	IT Personnel
Power Module	Inspect for dust at intake, vacuum as required using a vacuum cleaner that DOES NOT generate ESD (Electrostatic Discharge)	Monthly	IT Personnel
Battery harness	Inspect for wear, cracking, pinching, or other damage	Monthly	IT Personnel
Coiled Cord	Inspect for wear, damage, or stretching.	Weekly	Any user

1. Please dispose of all batteries in accordance with local law
 2. Always replace with similar size battery (33 A-h to replace 33 A-h) and always replace in pairs

Earth Bond Test: To ensure safety grounding between the power cord ground connection and any accessible metal parts on the cart, although not mandatory, the following test is recommended to be performed every two years using a calibrated medical device safety analyzer. The procedure is as follows:

1. Disconnect the cart from mains power (unplug cart from the wall).
2. Remove power from internal power system outlets by pressing the power button on the Power System Interface.
3. Set up Earth Bond Test per the medical device safety analyzer instructions.
4. Connect the Cart power cord to the medical device safety analyzer.
5. Remove cover to access Lift Tension Adjustment point.
6. Attach second medical safety device analyzer probe to Lift Tension Adjustment point on Cart.
7. Perform Test (25 amps).
8. Ensure Earth Bond is less than or equal to 0.2-ohms.
9. Remove medical device safety analyzer connections to Cart, replace cover over Lift Tension Adjustment point, return the Cart to service.



Insulation Resistance Test: To ensure mains power lines are adequately insulated from earth ground, the following test, although not mandatory, is recommended to be performed annually using a calibrated medical device safety analyzer. The procedure is as follows:

1. Disconnect the cart from mains power (unplug cart from the wall).
2. Remove power from internal power system outlets by pressing the power button on the Power System Interface.
3. Set up the Insulation Resistance Test per the medical device safety analyzer instructions.
4. Connect the Cart power cord to the medical device safety analyzer.
5. Perform test (500 V).
6. Ensure Insulation Resistance is greater than or equal to 1 Mohms.
7. Remove medical device safety analyzer connections to Cart and return Cart to service.

⚠ DANGER!

ELECTRICAL CORDS CAN BE HAZARDOUS
 Misuse Can Result in FIRE or DEATH by ELECTRICAL SHOCK.
 Please Read and Follow Product Manual Instructions.
THIS IS A POLARIZED CORD - HOSPITAL GRADE ONLY
NOTE: Grounding Reliability Can Only Be Achieved When the Equipment Is Connected To An Equivalent Receptacle Marked "HOSPITAL ONLY" Or "HOSPITAL GRADE"

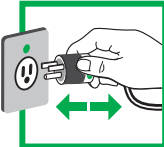
820-872

- Inspect Cord Thoroughly Before Each Use. DO NOT USE IF DAMAGED.
- Do Not Plug More Than SPECIFIED NUMBER OF WATTS Into Power System.
- Do Not Run Cord Through Doorways, Holes in Ceilings, Walls or Floors.
- FULLY INSERT Plug Into Outlet.
- Do Not Remove, Bend or Modify Any Metal Prongs or Pins of Cord.
- Do Not Use Excessive Force to Make Connections.
- Keep Away From Water. DO NOT USE WHEN WET.
- Keep Children Away From Cord.
- Do Not Plug Cord into An Extension Cord.
- AVOID OVERHEATING. Uncoil Cord and Do Not Cover It With Any Material.
- Do Not Drive, Drag or Place Objects Over Cord. Do Not Walk On Cord.
- GRASP PLUG TO REMOVE FROM Outlet. Do Not Unplug By Pulling On Cord.

Guidance and Manufacturer's Declaration – Electromagnetic Emissions		
The Powered Computer Cart is intended for use in the electromagnetic environment specified below. The customer or the user of the Powered Computer Cart should assure that it is used in such an environment.		
Emissions Test	Compliance	Electromagnetic environment – guidance
RF Emissions CISPR 11	Group 1	The Powered Computer Cart uses RF energy only for its internal function. Therefore, its RF emissions are very low and unlikely to cause any interference in nearby electronic equipment.
RF Emissions CISPR 11	Class A	The Powered Computer Cart is suitable for use in all establishments other than domestic and those directly connected to the public low-voltage power supply network that supplies buildings used for domestic purposes.
Harmonic Emissions IEC 61000-3-2	Class A	
Voltage fluctuations/ flicker emissions IEC 61000-3-3	Complies	

Guidance and Manufacturer's Declaration – Electromagnetic Immunity			
The Powered Computer Cart is intended for use in the electromagnetic environment specified below. The customer or the user of the Powered Computer Cart should assure that it is used in such an environment.			
Immunity Test	IEC 60601 Test Level	Compliance Level	Electromagnetic environment - guidance
Electrostatic Discharge (ESD) IEC 61000-4-2	±6 kV contact ±8 kV air	Complies	Floors should be wood, concrete, or ceramic tile. If floors are covered with synthetic material, the relative humidity should be at least 30%
Electrical Fast Transient/Burst IEC 61000-4-3	±2 kV for power supply lines ±1 kV for input/output lines	Complies	Mains power quality should be that of a typical commercial or hospital environment.
Surge IEC 61000-4-5	±1 kV differential mode ±2 kV common mode	Complies	Mains power quality should be that of a typical commercial or hospital environment
Voltage Dips, short interruptions, and voltage variations on power supply input lines IEC 61000-4-11	<5% U_T (>95% dip in U_T) for 0.5 cycle 40% U_T (60% dip in U_T) for 5 cycles 70% U_T (30% dip in U_T) for 25 cycles <5% U_T (>95% dip in U_T) for 5 seconds	Complies	Mains power quality should be that of a typical commercial or hospital environment.
Power Frequency (50/60 Hz) Magnetic Field IEC 61000-4-8	3 A/m	Complies	Power frequency magnetic fields should be at levels characteristic of a typical location in a typical commercial or hospital environment.
Note: U_T is the AC mains voltage prior to application of the test level			

Americas Sales and Corporate Headquarters

1181 Trapp Rd.
St. Paul, MN USA
(800) 888-8458
+1-651-681-7600
www.ergotron.com
sales@ergotron.com

EMEA Sales

Amersfoort, The Netherlands
+31 33 45 45 600
www.ergotron.com
info.eu@ergotron.com

APAC Sales

Tokyo, Japan
www.ergotron.com
apaccustomerservice@ergotron.com

Worldwide OEM Sales

www.ergotron.com
info.oem@ergotron.com



© 2012 Ergotron, Inc.
All rights reserved.

While Ergotron, Inc. makes every effort to provide accurate and complete information on the installation and use of its products, it will not be held liable for any editorial errors or omissions (including those made in the process of translation from English to another language), or for incidental, special or consequential damages of any nature resulting from furnishing this instruction and performance of equipment in connection with this instruction. Ergotron, Inc. reserves the right to make changes in the product design and/or product documentation without notification to its users. For the most current product information, or to know if this document is available in languages other than those herein, please contact Ergotron. No part of this publication may be reproduced, stored in a retrieval system, or transmitted in any form or by any means, electronic, mechanical, photocopying, recording or otherwise without the prior written consent of Ergotron, Inc., 1181 Trapp Road, Eagan, Minnesota, 55121, USA. Patents Pending and Patented U.S. & Foreign. Ergotron is a registered trademark of Ergotron, Inc.