

WorkFit-S, Single LCD Mount, HD

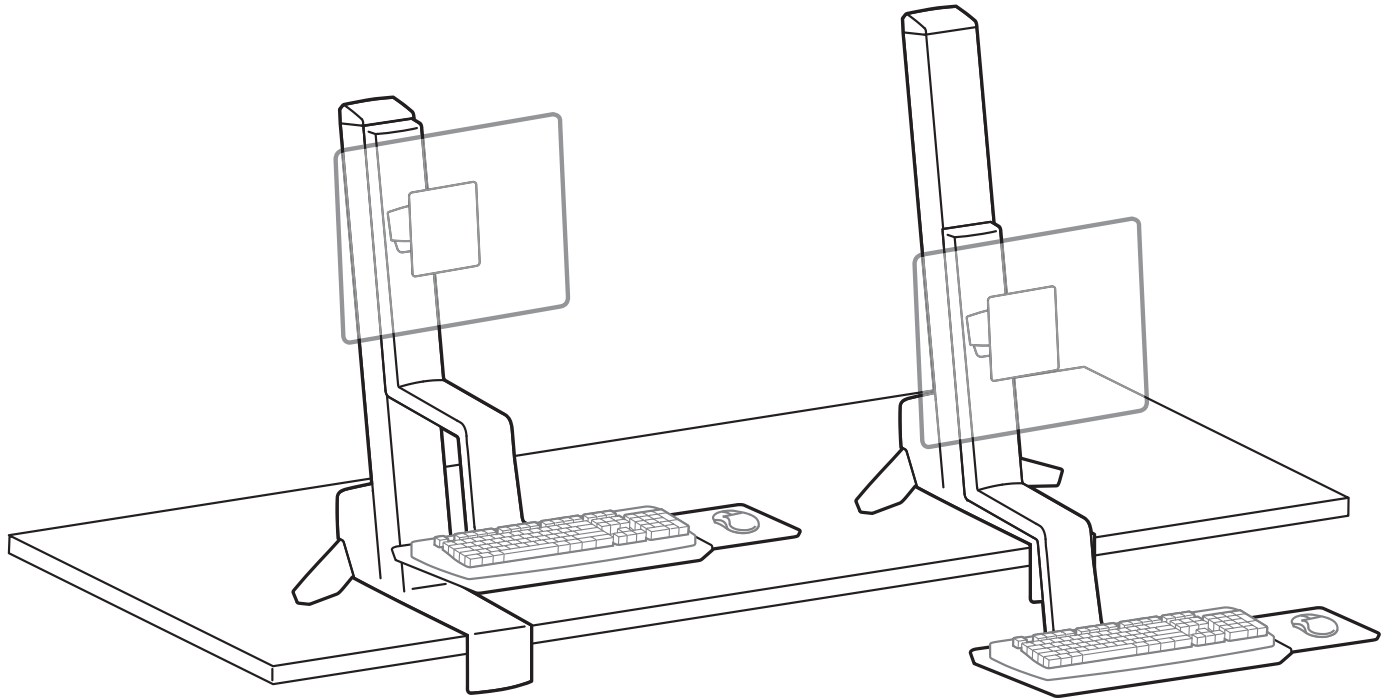

ENGLISH

LB kg CAUTION: DO NOT EXCEED MAXIMUM LISTED WEIGHT CAPACITY. SERIOUS INJURY OR PROPERTY DAMAGE MAY OCCUR!

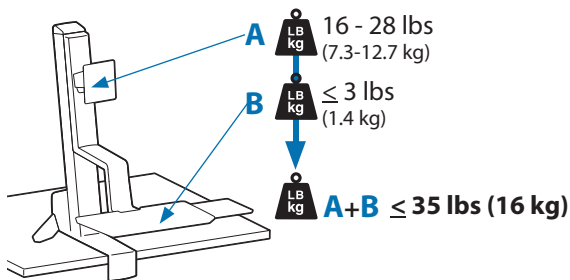

For the latest User Installation Guide please visit: www.ergotron.com



User's Guide - English
 Guía del usuario - Español
 Manuel de l'utilisateur - Français
 Gebruikersgids - Deutsch
 Benutzerhandbuch - Nederlands
 Guida per l'utente - Italiano
 Användarhandbok - svenska
 ユーザーガイド : 日本語
 用户指南 : 汉语



Includes
 Constant Force™
 Technology







www.ergotron.com

USA 1-800-888-8458
 Europe +31 (0)33-45 45 600
 China 400-120-3051

Hazard Symbols Review

These symbols alert users of a safety condition that demands attention. All users should be able to recognize and understand the significance of the following Safety Hazards if encountered on the product or within the documentation. Children who are not able to recognize and respond appropriately to Safety Alerts should not use this product without adult supervision!

Symbol	Signal Word	Level of Hazard
	NOTE	A NOTE indicates important information that helps you make better use of this product.
	CAUTION	A CAUTION indicates either potential damage to hardware or loss of data and tells you how to avoid the problem.
	WARNING	A WARNING indicates either potential for property damage, personal injury, or death.
	ELECTRICAL	An Electrical indicates an impending electrical hazard which, if not avoided, may result in personal injury, fire and/or death.

Safety



Important! You will need to adjust this product after installation is complete. Make sure all your equipment is properly installed on the product before attempting adjustments. This product should move smoothly and easily through the full range of motion and stay where you set it. If movements are too easy or difficult or if product does not stay in desired positions, follow the adjustment instructions to create smooth and easy movements. Depending on your product and the adjustment, it may take many turns to notice a difference. Any time equipment is added or removed from this product, resulting in a change in the weight of the mounted load, you should repeat these adjustment steps to ensure safe and optimum operation.

 **Warning:** Because mounting surface materials can vary widely, it is imperative that you make sure mounting surface is strong enough to handle mounted product and equipment.

 **Caution:** To avoid the potential to pinch cables it is important to follow the cable routing instructions in this manual. Failure to follow these instructions may result in equipment damage or personal injury.

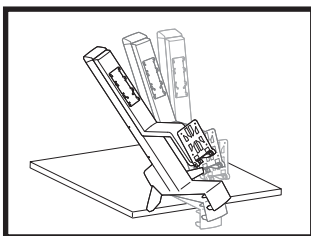

CAUTION! Tipping Hazard. Support the stand until the clamp is securely tightened. Failure to follow these instructions may result in the stand tipping over causing possible equipment damages and or personal injury.



Important! You will need to adjust this product after installation is complete. Make sure all your equipment is properly installed on the product before attempting adjustments. This product should move smoothly and easily through the full range of motion and stay where you set it. If movements are too easy or difficult or if product does not stay in desired positions, follow the adjustment instructions to create smooth and easy movements. Depending on your product and the adjustment, it may take many turns to notice a difference. Any time equipment is added or removed from this product, resulting in a change in the weight of the mounted load, you should repeat these adjustment steps to ensure safe and optimum operation.

GREEN ARROWS MARK IMPORTANT ADJUSTMENT POINTS

1 Follow Steps 1 - 8 for Installation



2 After installation, adjust product to properly handle added weight.



To view a video on this adjustment procedure, go to
install.ergotron.com

Features & Specifications

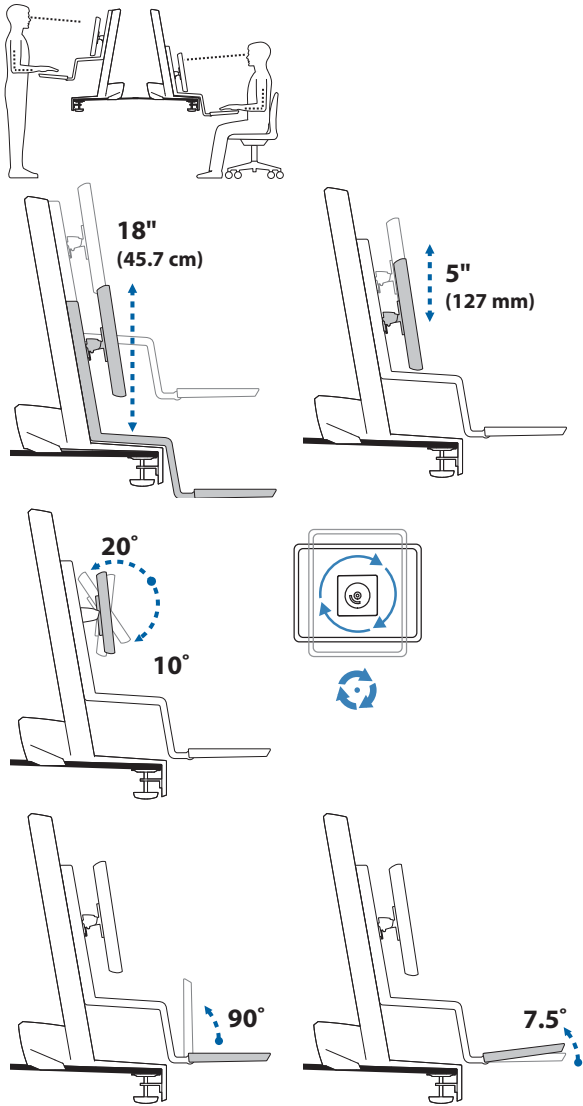

Components

		A	B
1	1x		3x M5 x 14mm
2	1x		1x M5 x 8mm
3	4x		4x M5 x 18mm
4	1x		1x M3 x 6mm
5	1x		4x M4 x 10mm
6	1x		4x M4 x 10mm
7	1x		3x
			2x
8	1x		1x 4mm
	3x		
9	1x		1x 3mm

Tools Needed



1

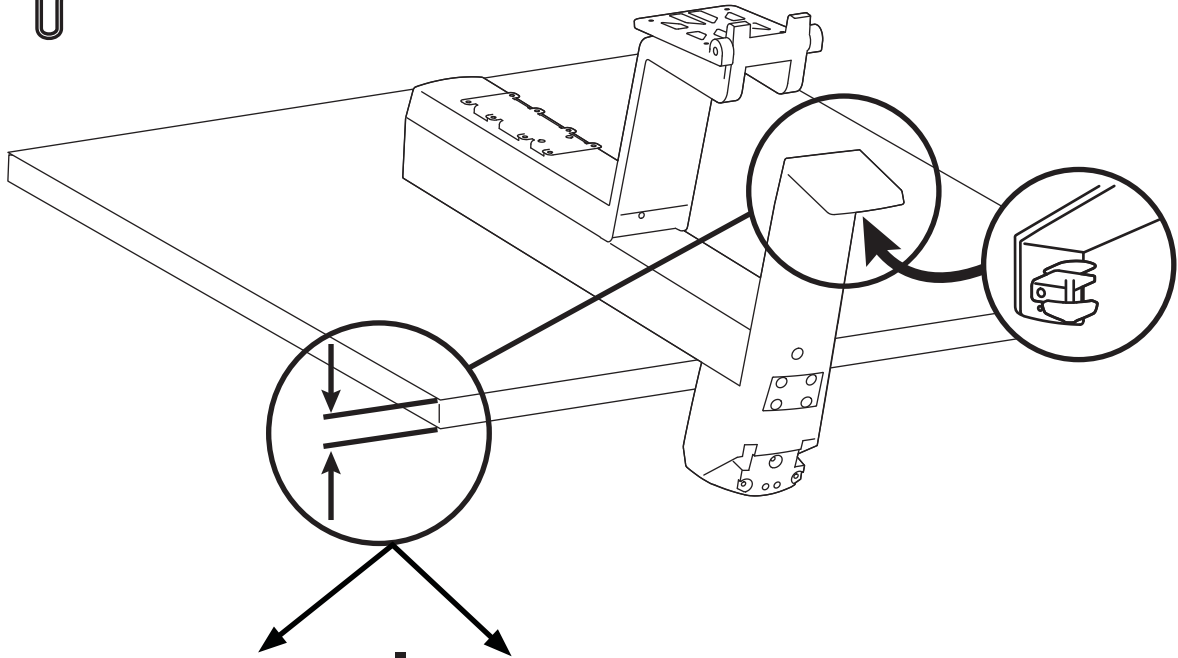
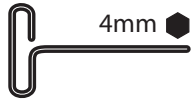

0.47" - 1.38" (12 - 35 mm)

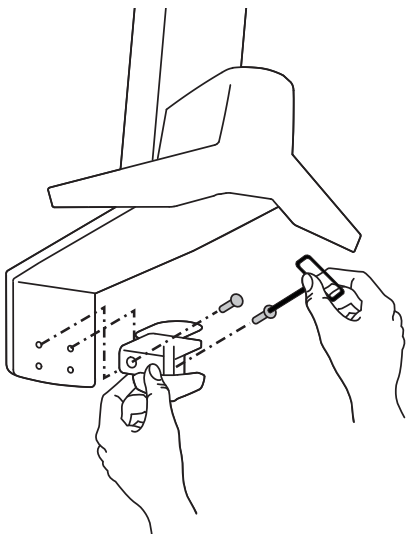
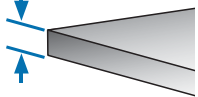

1.46" - 2.4" (37 - 60 mm)

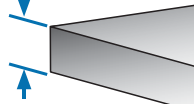

1

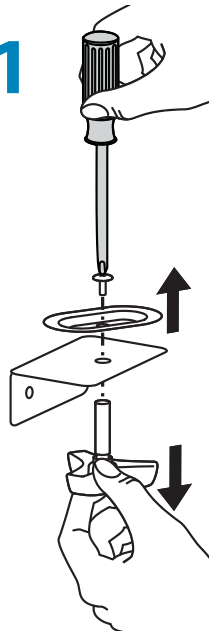

2

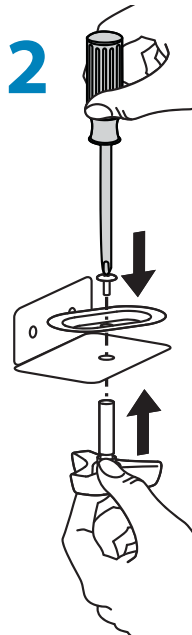

3

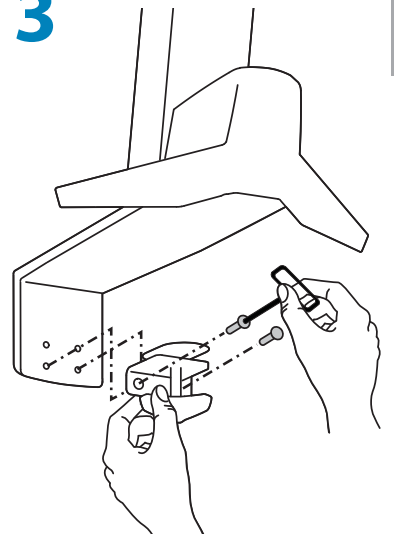

2

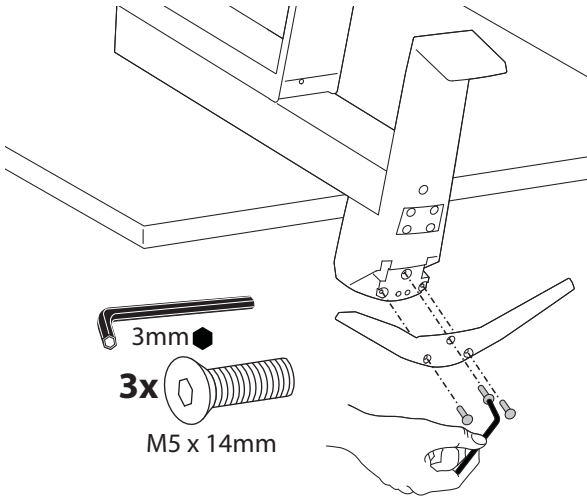

3

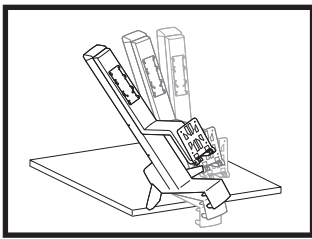

a

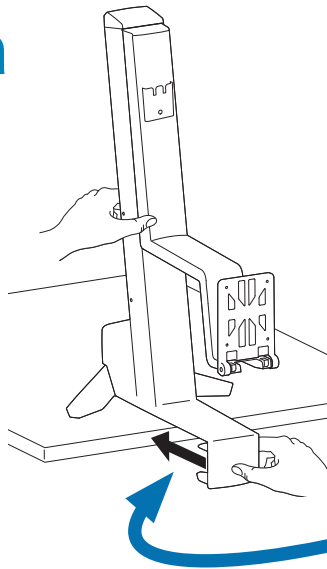

b

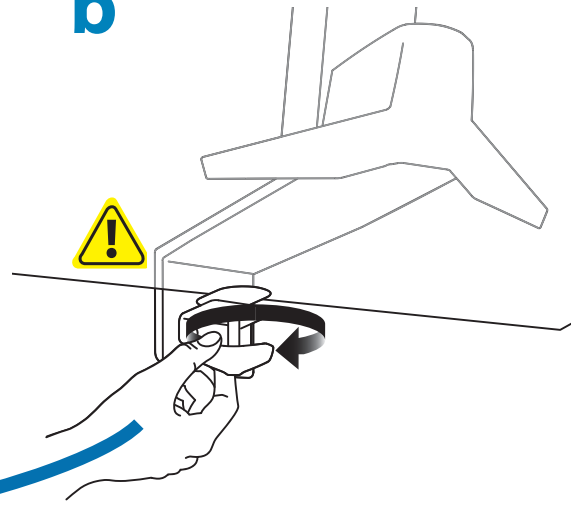

CAUTION! Tipping Hazard. Support the stand until the clamp is securely tightened. Failure to follow these instructions may result in the stand tipping over causing possible equipment damages and or personal injury.

ENGLISH

4

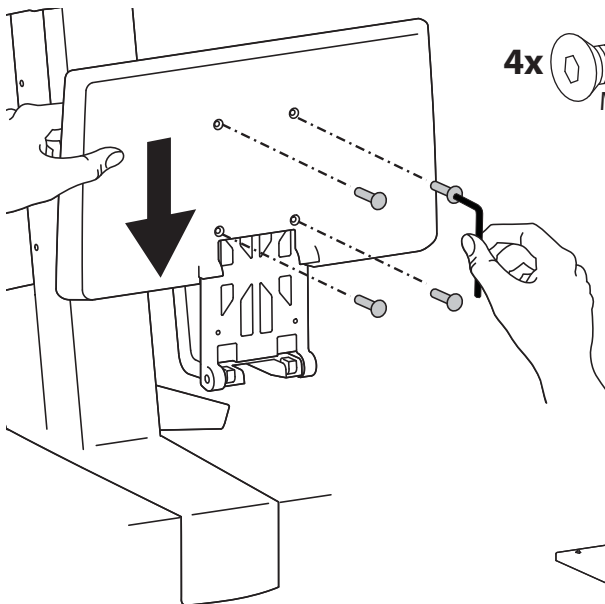

4x M5 x 18mm

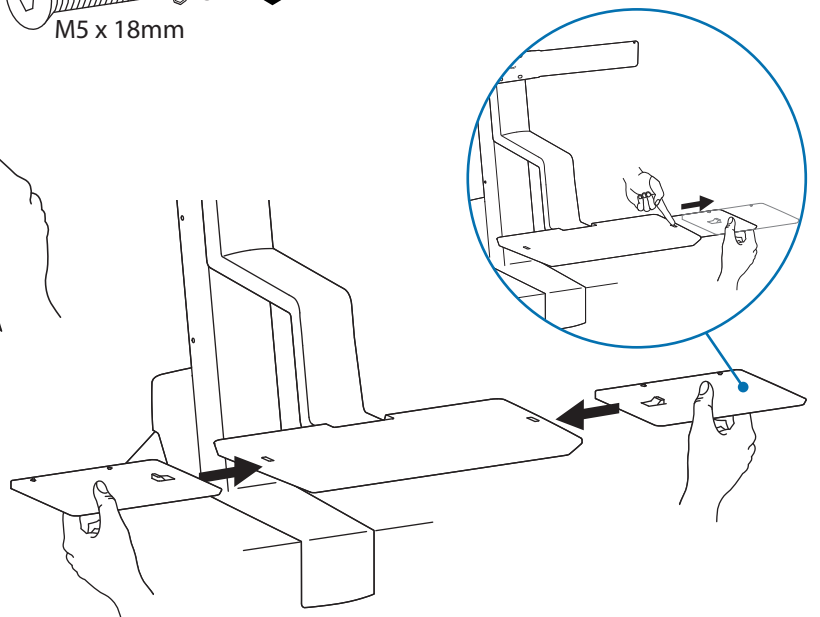

5

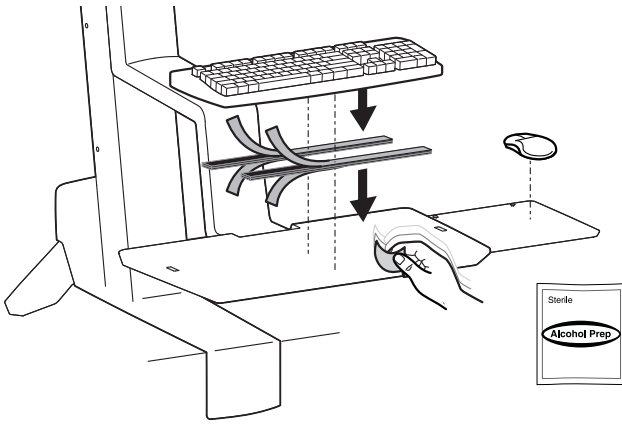

6

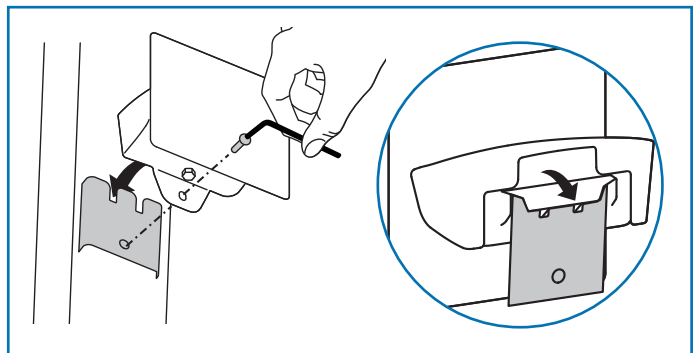
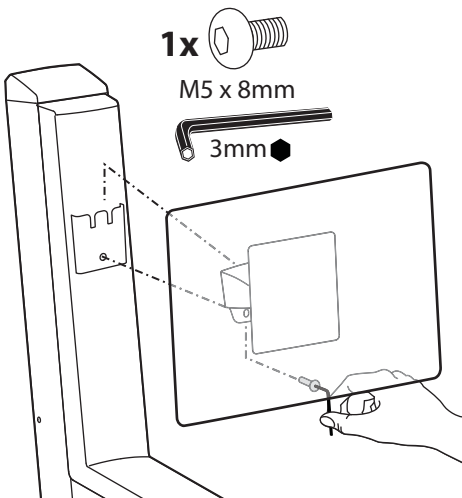
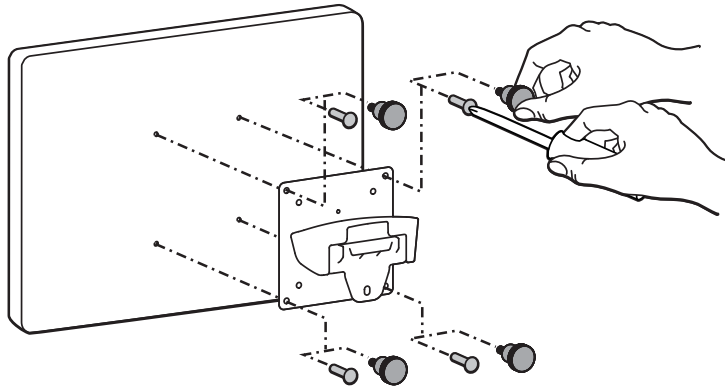
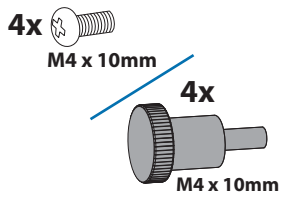
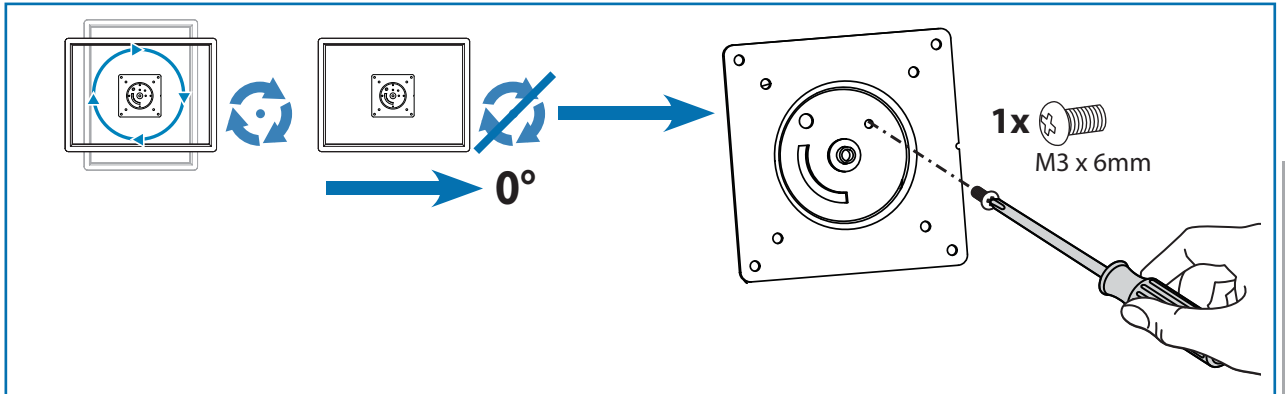

7



NOTE: Leave enough slack in cable to allow full range of motion.



Caution: To avoid the potential to pinch cables it is important to follow the cable routing instructions in this manual. Failure to follow these instructions may result in equipment damage or personal injury.

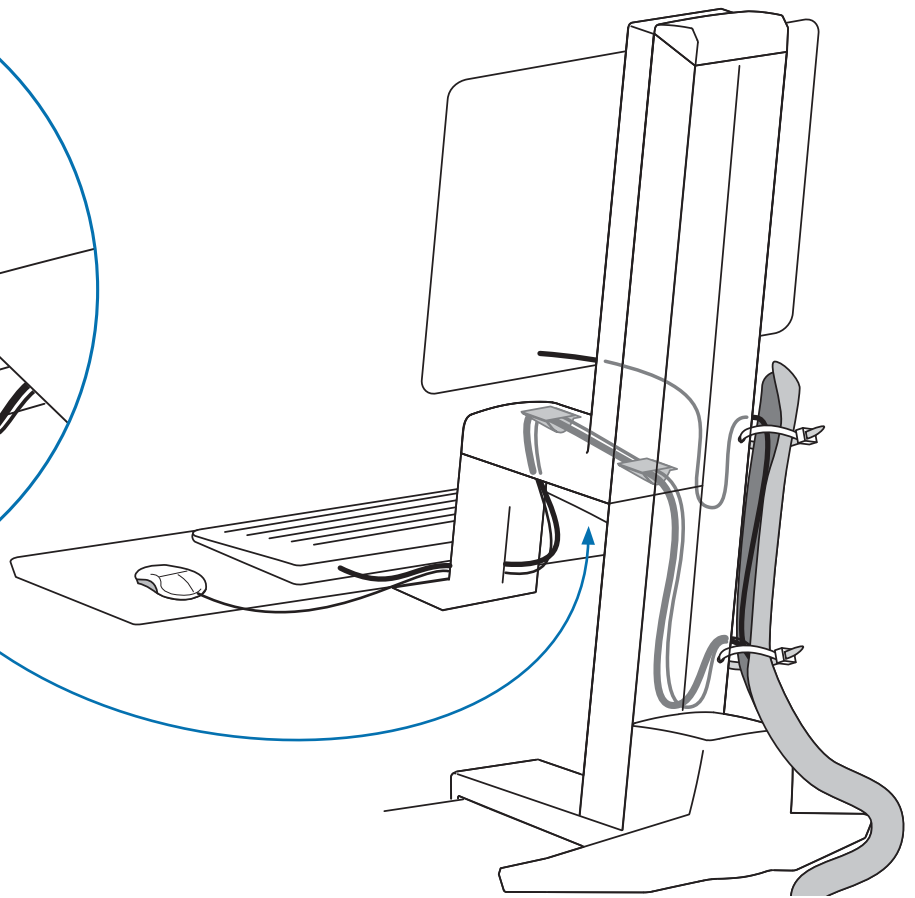
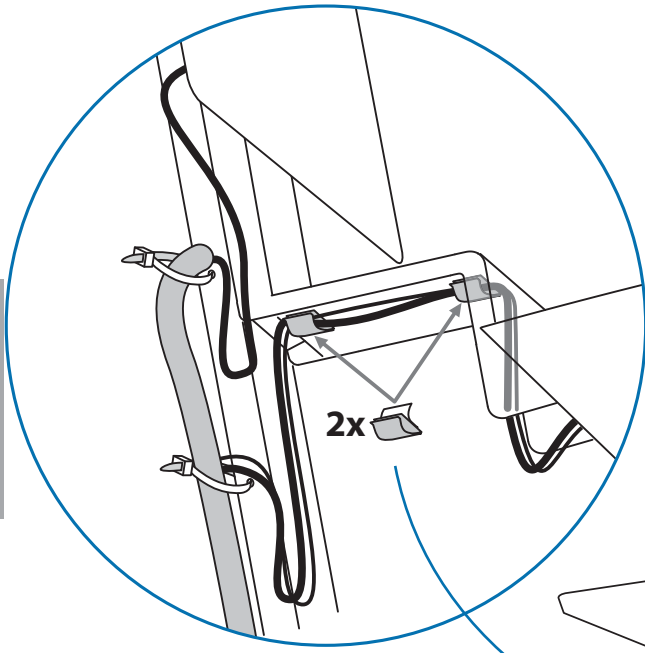
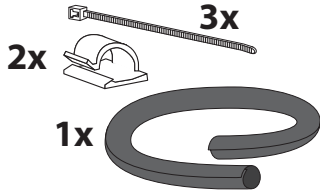

ENGLISH

8



Adjustment Step

Important! You will need to adjust this product after installation is complete. Make sure all your equipment is properly installed on the product before attempting adjustments. This product should move smoothly and easily through the full range of motion and stay where you set it. If movements are too easy or difficult or if product does not stay in desired positions, follow the adjustment instructions to create smooth and easy movements. Depending on your product and the adjustment, it may take many turns to notice a difference. Any time equipment is added or removed from this product, resulting in a change in the weight of the mounted load, you should repeat these adjustment steps to ensure safe and optimum operation.

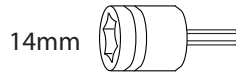
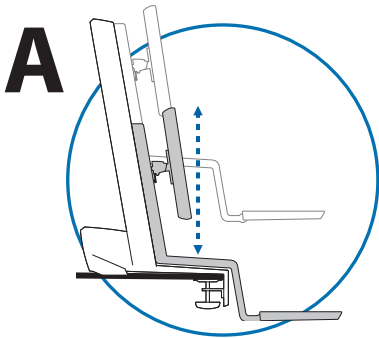

Increase Lift Strength

If the mounted weight is too heavy or this product does not stay up when raised, then you'll need to increase Lift Strength:



Decrease Lift Strength

If the mounted weight is too light or this product does not stay down when lowered, then you'll need to decrease Lift Strength:

⚠ WARNING
STORED ENERGY HAZARD!
DO NOT OPEN TOWER OR REMOVE SAFETY GUARD!

A primary mechanism within the tower is under tension and can be hazardous to people exposed to it under certain extreme conditions. DO NOT open the tower; DO NOT attempt to service the cart/stand. DO NOT remove safety guards or labels designed to protect or inform of possible hazards. Only Ergotron-approved installers may service or otherwise modify cart/stand. Failure to heed this Warning may result in serious Personal Injury and Damage both to the cart/stand and equipment. 822-959-00

Adjustment may take up to: 72 full 360° revolutions

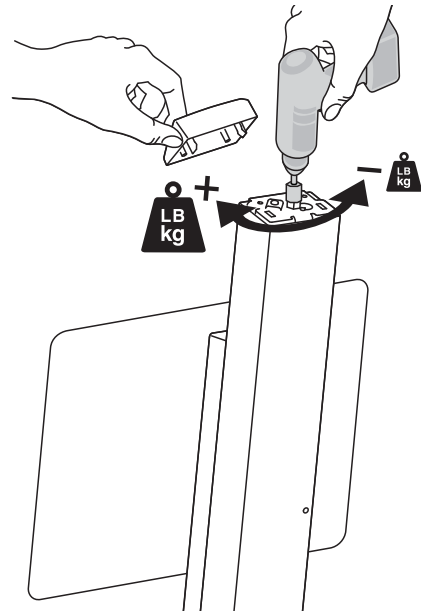

B

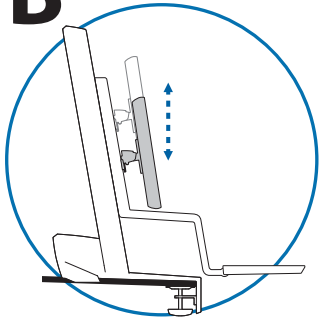

Increase Lift Strength

If the mounted weight is too heavy or this product does not stay up when raised, then you'll need to increase Lift Strength:

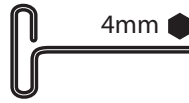

Decrease Lift Strength

If the mounted weight is too light or this product does not stay down when lowered, then you'll need to decrease Lift Strength:

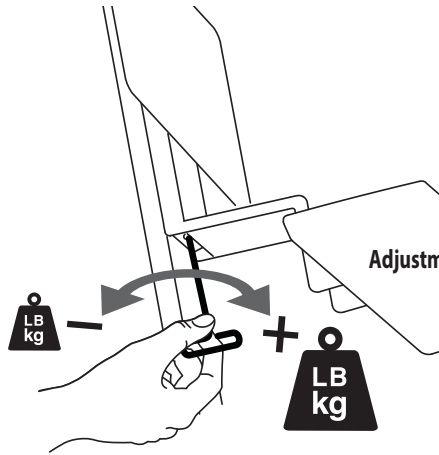

Adjustment may take up to: 115 full 360° revolutions

C

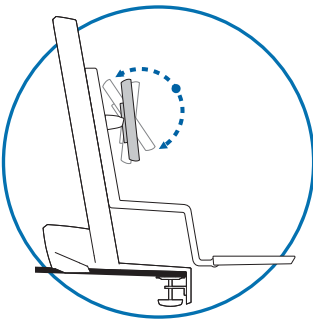

Increase Lift Strength

If the mounted weight is too heavy or this product does not stay up when raised, then you'll need to increase Lift Strength:

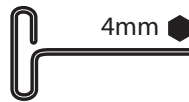

Decrease Lift Strength

If the mounted weight is too light or this product does not stay down when lowered, then you'll need to decrease Lift Strength:

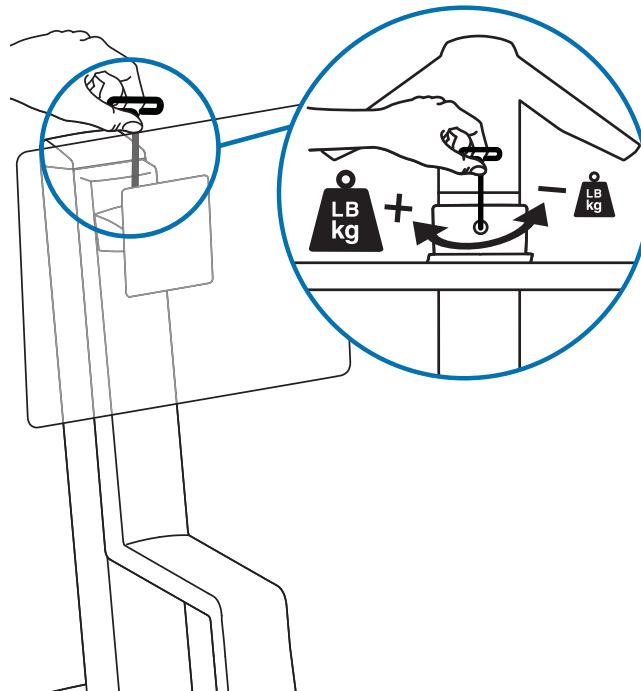

D

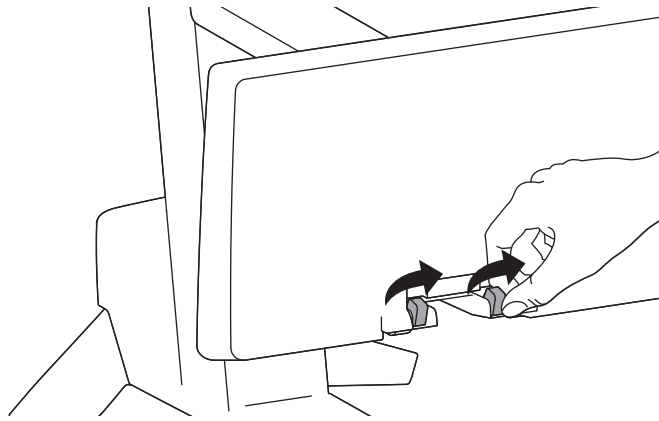
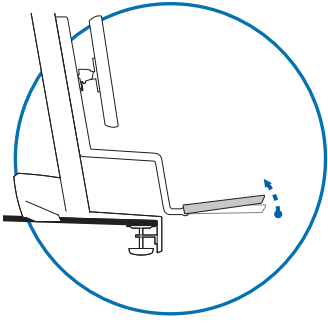

9 How to attach optional CPU holder ordered separately

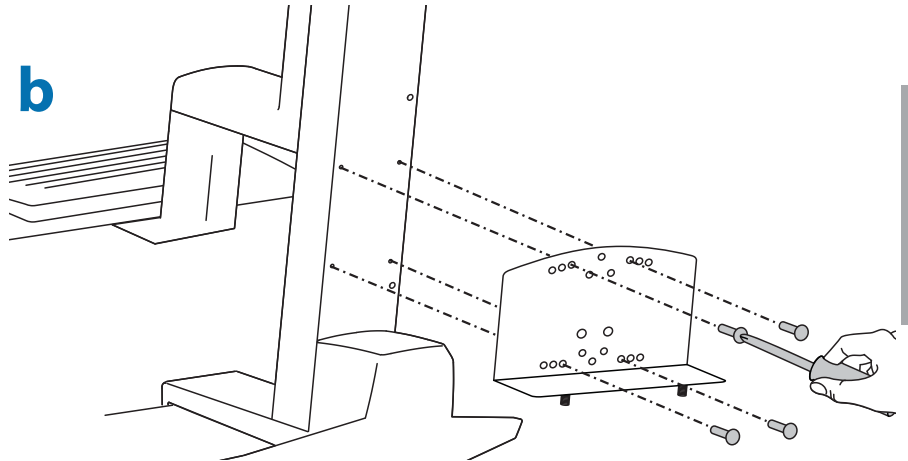
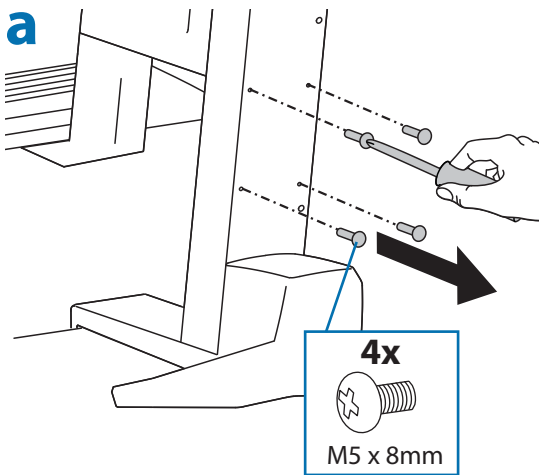
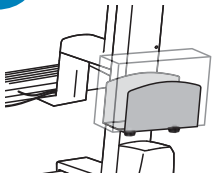

Set Your Workstation to Work For YOU!

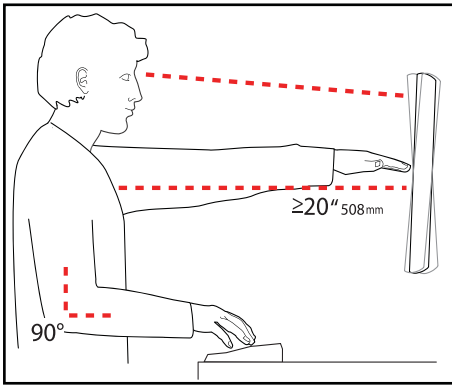

Learn more about ergonomic computer use at:
www.computingcomfort.org

- Height** Position top of screen slightly below eye level.
Position keyboard at about elbow height with wrists flat.
- Distance** Position screen an arm's length from face—at least 20" (508mm).
Position keyboard close enough to create a 90° angle in elbow.
- Angle** Tilt screen to eliminate glare.
Tilt the keyboard back 10° so that your wrists remain flat.

To Reduce Fatigue

- Breathe - Breathe deeply through your nose.
- Blink - Blink often to avoid dry eyes.
- Break • 2 to 3 minutes every 20 minutes
- 15 to 20 minutes every 2 hours.

For Warranty visit: www.ergotron.com/warranty

For Service visit: www.ergotron.com

For local customer care phone numbers visit: <http://contact.ergotron.com>

Americas Sales and Corporate Headquarters

1181 Trapp Rd.
St. Paul, MN USA
(800) 888-8458
+1-651-681-7600
www.ergotron.com
sales@ergotron.com

EMEA Sales

Amersfoort, The Netherlands
+31 33 45 45 600
www.ergotron.com
info.eu@ergotron.com

APAC Sales

Tokyo, Japan
www.ergotron.com
apaccustomerservice@ergotron.com

Worldwide OEM Sales

www.ergotron.com
info.oem@ergotron.com

ERGOTRON®

While Ergotron, Inc. makes every effort to provide accurate and complete information on the installation and use of its products, it will not be held liable for any editorial errors or omissions (including those made in the process of translation from English to another language), or for incidental, special or consequential damages of any nature resulting from furnishing this instruction and performance of equipment in connection with this instruction. Ergotron, Inc. reserves the right to make changes in the product design and/or product documentation without notification to its users. For the most current product information, or to know if this document is available in languages other than those herein, please contact Ergotron. No part of this publication may be reproduced, stored in a retrieval system, or transmitted in any form or by any means, electronic, mechanical, photocopying, recording or otherwise without the prior written consent of Ergotron, Inc., 1181 Trapp Road, Eagan, Minnesota, 55121, USA. Patents Pending and Patented U.S. & Foreign. Ergotron is a registered trademark of Ergotron, Inc.

© 2015 Ergotron, Inc. All rights reserved.