

# Installing Wall Plate to Metal Stud Walls

Models: D-FPF-220, D-FPF-220S, D-FPF-320, D-FPF-320S, D-FPT-220, D-FPT-220S, D-FPT-320, D-FPT-320S, DFPT-420, DFPT-420S, RTFPF-220, RTFPF-220S, RTFPF-220I, RTFPF-220SI, RTFPF-220I, RTFPF-220SI, RTFPF-320, RTFPF-320I, RTFPF-320S, RTFPF-320SI, RTFPF-320I, RTFPF-320S, RTFPF-320SI, SF640, SF640P, SF640-S, SF640P-S, SF650, SF650-S, SF650P, SF650P-S, SF660, SF660-S, SF660P, SF660P-S, ST640, ST640-S, ST640P, ST640P-S, ST650, ST650-S, ST650P, ST650P-S, ST660, ST660-S, ST660P, ST660P-S

## Installation to Double Metal Stud Wall (Metal Stud Accessory Kit ACC 415 Required)

### ⚠ WARNING

- Drywall must be 1/2" or thicker, and metal stud must be 24 gauge or thicker.
- Installer must verify that the supporting surface will safely support the combined load of the equipment and all attached hardware and components.

**1** Wall plate (AA) can be mounted to two studs that are 16" apart. Use a stud finder to locate the edges of the studs. Use of an edge-to-edge stud finder is highly recommended. Based on their edges, draw a vertical line down each stud's center. Place wall plate on wall as a template. The top mounting slots should be located above the desired screen center as indicated by dimension X in figure 1.1 and chart below. Level plate, and mark the center of the four mounting holes. Make sure that the mounting holes are on the stud centerlines. Drill four 1/2" holes through drywall and metal studs. **Note:** It may be necessary to drill 5/32" pilot holes prior to drilling 1/2" holes.

Refer to instruction sheet included with Peerless accessory kit ACC 415 for metal studs to install togglers. Loosely fasten mount assembly (AA) to wall using four 1/4-20 x 2-1/2" screws as shown in figure 1.2.

**Note:** Wall plate may be mounted up to 4" (102 mm) off center as shown in figure 1.1.

Level, hold, and then tighten all screws.

Skip to step 2 of main instruction sheet.

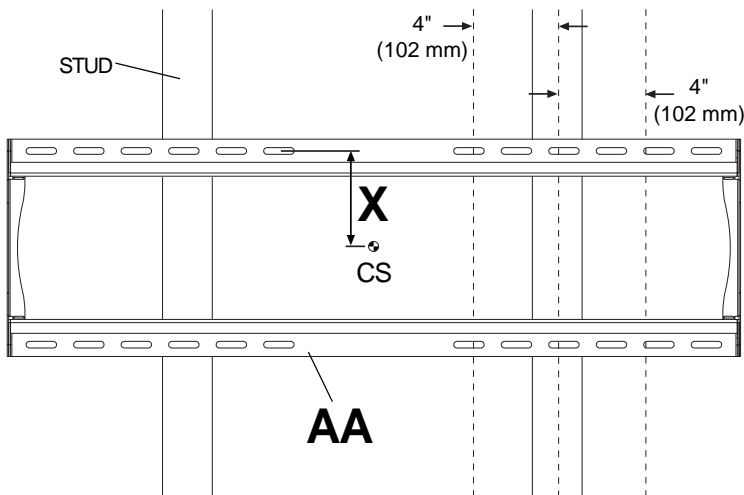

CS = Center of Screen  
X = See Chart

fig. 1.1

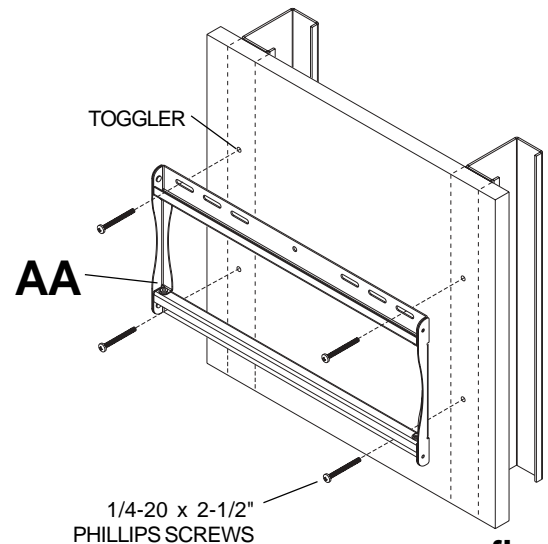

fig. 1.2

Model #	X Dimension
D-FPF-220, D-FPF-220S, D-FPT-220, D-FPT-220S, D-FPT-220, D-FPT-220S, RTFPF-220, RTFPF-220S, RTFPF-220I, RTFPF-220SI, SF640, SF640-S, SF640P, SF640P-S, ST640, ST640-S, ST640P, ST640P-S	4.07" (103 mm)
D-FPF-320, D-FPF-320S, D-FPT-320, D-FPT-320S, DFPT-420, DFPT-420S, SF650, SF650-S, SF650P, SF650P-S, ST650, ST650-S, ST650P, ST650P-S, SF660, SF660-S, SF660P, SF660P-S, ST660, ST660-S, ST660P, ST660P-S, RTFPF-320, RTFPF-320I, RTFPF-320S, RTFPF-320SI, RTFPF-320I, RTFPF-320S, RTFPF-320SI	6.2" (157.5 mm)

**Instalación de la placa de apoyo en paredes con montantes de metal**

**Modelos:** D-FPF-220, D-FPF-220S, D-FPF-320, D-FPF-320S, D-FPT-220, D-FPT-220S, D-FPT-320, D-FPT-320S, DFPT-420, DFPT-420S, RTFPF-220, RTFPF-220S, RTFPF-220I, RTFPF-220SI, RTFPF-220SI, RTFPF-220SI, RTFPF-320, RTFPF-320I, RTFPF-320S, RTFPF-320SI, RTFPF-320SI, RTFPF-320I, RTFPF-320S, RTFPF-320SI, SF640, SF640P, SF640-S, SF640P-S, SF650, SF650-S, SF650P, SF650P-S, SF660, SF660-S, SF660P, SF660P-S, ST640, ST640-S, ST640P, ST640P-S, ST650, ST650-S, ST650P, ST650P-S, ST660, ST660-S, ST660P, ST660P-S

**Instalación en una pared con montantes de metal dobles (se requiere el juego de accesorios para montantes de metal ACC415)**

**⚠ ADVERTENCIA**

- El tabique de yeso-cartón debe tener un espesor de 1/2" o más grueso, y el montante de metal debe ser calibre 24 o más grueso.
- El instalador debe verificar que la superficie de apoyo sea capaz de soportar firmemente la carga combinada del equipo y todos los herrajes y componentes

**1** La placa de apoyo (AA) puede fijarse a dos montantes con una separación de 16" entre ellos. Utilice un localizador de montantes para ubicar los bordes de los montantes. Se recomienda usar un localizador de montantes de "borde a borde". Basado en sus bordes, trace una línea vertical por el centro de cada montante. Coloque la placa de apoyo en la pared para usarla como plantilla. Las ranuras de montaje superiores deben quedar ubicadas más arriba del centro de la pantalla, como lo indica la dimensión X en la figura 1.1 y en la tabla que aparece a continuación. Nivele la placa y marque el centro de los cuatro agujeros. Asegúrese de que los agujeros de montaje se encuentren en la línea central de los montantes. Taladre cuatro agujeros de 1/2" a través del tabique de yeso-cartón y los montantes de metal. **Nota:** Podría ser necesario taladrar agujeros piloto de 5/32" antes de taladrar los agujeros de 1/2".

**Para instalar pernos Toggler (anclaje de vuelco), vea la hoja de instrucciones que se incluye con el juego de accesorios ACC 415 de Peerless para montantes de metal.**

Fije, sin apretar, la placa de apoyo (AA) a la pared usando cuatro tornillos de 1/4-20 x 2-1/2", como se muestra en la figura 1.2.

**Nota:** La placa de apoyo puede instalarse hasta 4" (102 mm) desplazada del centro, como se muestra en la figura 1.1.

Nivele, sujete y apriete todos los tornillos  
*Proceda al paso 2.*

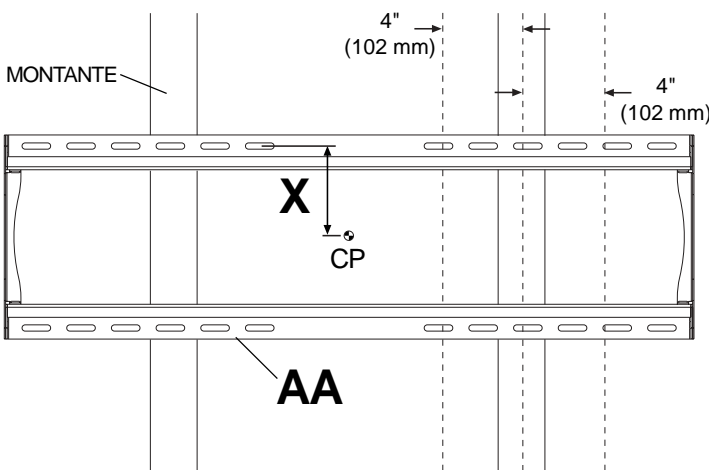

CP = centro de la pantalla

**fig. 1.1**

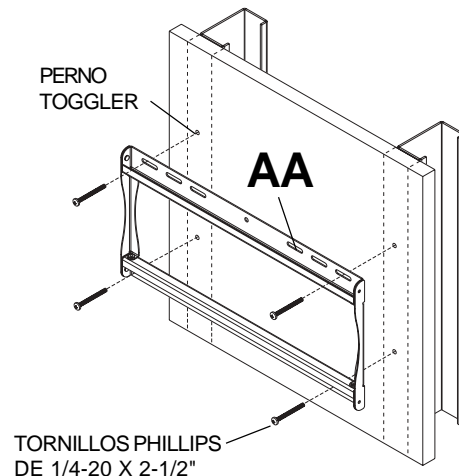

**fig. 1.2**

Nº de modelo	X Dimensión
D-FPF-220, D-FPF-220S, D-FPT-220, D-FPT-220S, D-FPT-220, D-FPT-220S, RTFPF-220, RTFPF-220S, RTFPF-220I, RTFPF-220SI, SF640, SF640-S, SF640P, SF640P-S, ST640, ST640-S, ST640P, ST640P-S	4.07" (103 mm)
D-FPF-320, D-FPF-320S, D-FPT-320, D-FPT-320S, DFPT-420, DFPT-420S, SF650, SF650-S, SF650P, SF650P-S, ST650, ST650-S, ST650P, ST650P-S, SF660, SF660-S, SF660P, SF660P-S, ST660, ST660-S, ST660P, ST660P-S, RTFPF-320, RTFPF-320I, RTFPF-320S, RTFPF-320SI, RTFPF-320I, RTFPF-320S, RTFPF-320SI	6.2" (157.5 mm)

## Installation d'une plaque murale sur des murs à montants métalliques

Modèles: D-FPF-220, D-FPF-220S, D-FPF-320, D-FPF-320S, D-FPT-220, D-FPT-220S, D-FPT-320, D-FPT-320S, DFPT-420, DFPT-420S, RTFPF-220, RTFPF-220S, RTFPF-220I, RTFPF-220SI, RTFPF-220I, RTFPF-220SI, RTFPF-320, RTFPF-320I, RTFPF-320S, RTFPF-320SI, RTFPF-320I, RTFPF-320S, RTFPF-320SI, SF640, SF640P, SF640-S, SF640P-S, SF650, SF650-S, SF650P, SF650P-S, SF660, SF660-S, SF660P, SF660P-S, ST640, ST640-S, ST640P, ST640P-S, ST650, ST650-S, ST650P, ST650P-S, ST660, ST660-S, ST660P, ST660P-S

## Installation sur un mur à doubles montants métalliques (Kit d'accessoires pour montants métalliques ACC 415 requis)

### ⚠ AVERTISSEMENT

- La cloison sèche doit avoir une épaisseur égale ou supérieure à 1,25 cm (1/2 po) et le montant métallique un calibre égal ou supérieur à 24.
- L'installateur doit s'assurer que la surface de support pourra soutenir sans danger la charge combinée de l'équipement, de toute sa visserie et de tous ses composants.

**1** La plaque murale (AA) peut être montée sur deux montants espacés de 40 cm (16 po). Utilisez un localisateur de montants pour repérer les bords des montants. L'usage d'un localisateur bord à bord est fortement conseillé. En fonction de leurs bords, tracez une ligne verticale le long du centre de chaque montant. Utilisez la plaque murale comme gabarit et placez-la sur le mur. Les fentes de montage supérieures doivent être situées au-dessus du centre de l'écran, comme indiqué par la dimension X sur la figure 1.1 et le tableau ci-dessous. Mettez la plaque de niveau et marquez le centre des quatre trous de montage. Assurez-vous que les trous de montage se trouvent sur les axes des montants. Percez quatre trous de 1,25 cm (1/2 po) dans la cloison sèche et les montants métalliques. **Remarque** : Il peut être nécessaire de percer des avant-trous de 0,3 cm (5/32 po) avant de percer des trous de 1,25 cm (1/2 po).

**La fiche d'instructions fournie avec le kit d'accessoires Peerless ACC 415 pour montants métalliques indique comment installer des articulations.**

Fixez sans la serrer la monture (AA) sur le mur à l'aide de quatre vis 1/4-20 x 2 1/2 po, comme illustré à la figure 1.2.

**Remarque** : La plaque murale peut être décentrée d'un maximum de 10,2 cm (4 po), comme indiqué à la figure 1.1.

Mettez de niveau, maintenez, puis serrez toutes les vis.

Passez à l'étape 2.

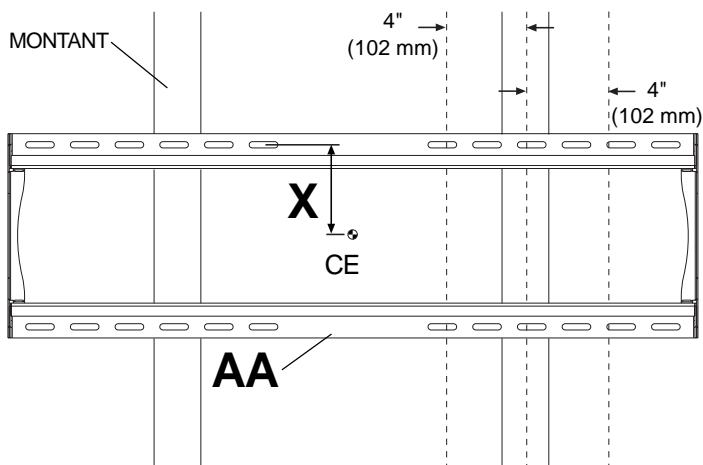

CE = centre de l'écran

fig. 1.1

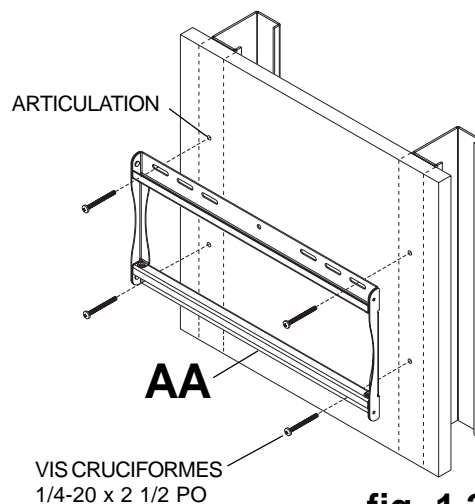

fig. 1.2

Modèle n°	Dimension X
D-FPF-220, D-FPF-220S, D-FPT-220, D-FPT-220S, D-FPT-220, D-FPT-220S, RTFPF-220, RTFPF-220S, RTFPF-220I, RTFPF-220SI, SF640, SF640-S, SF640P, SF640P-S, ST640, ST640-S, ST640P, ST640P-S	4.07" (103 mm)
D-FPF-320, D-FPF-320S, D-FPT-320, D-FPT-320S, DFPT-420, DFPT-420S, SF650, SF650-S, SF650P, SF650P-S, ST650, ST650-S, ST650P, ST650P-S, SF660, SF660-S, SF660P, SF660P-S, ST660, ST660-S, ST660P, ST660P-S, RTFPF-320, RTFPF-320I, RTFPF-320S, RTFPF-320SI, RTFPF-320I, RTFPF-320S, RTFPF-320SI	6.2" (157.5 mm)