

www.ergotron.com
 USA 1-800-888-8458
 Europe +31 (0)33-45 45 600
 China 86-769-86018920

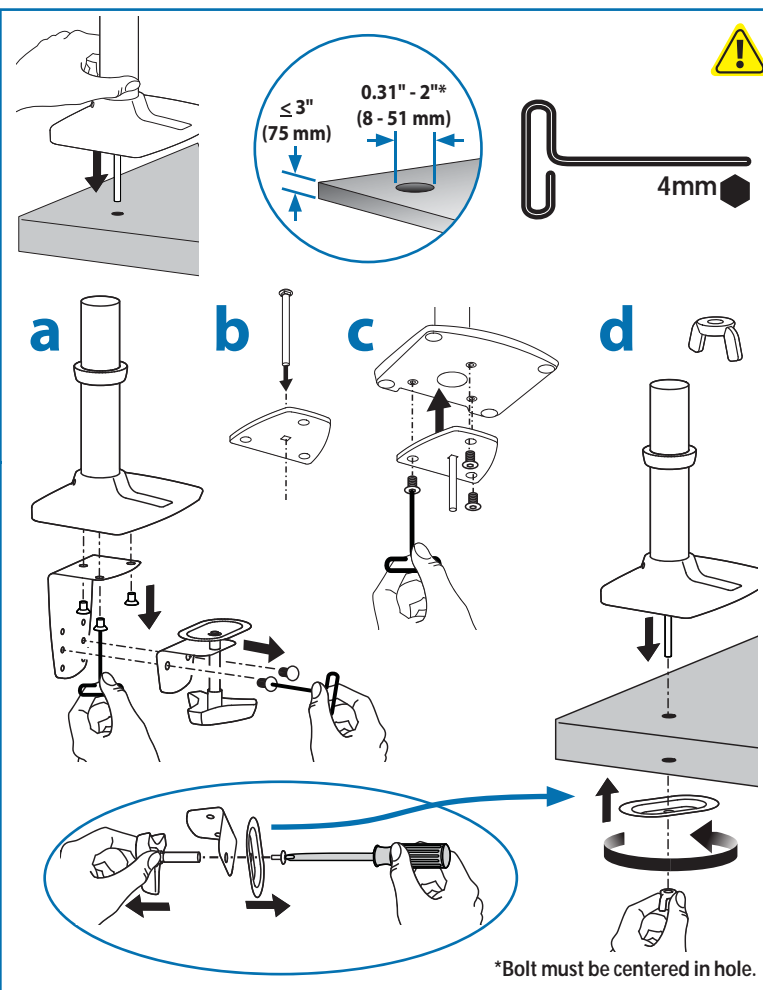
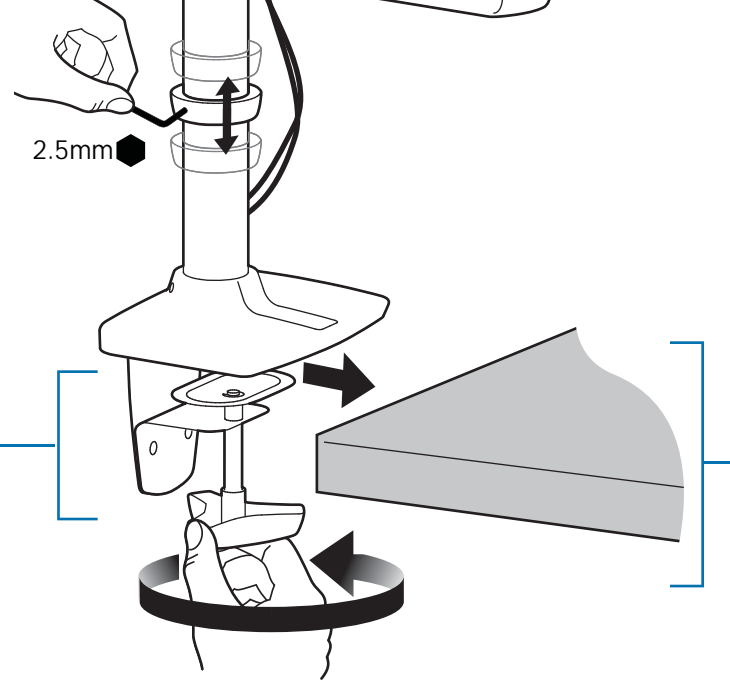
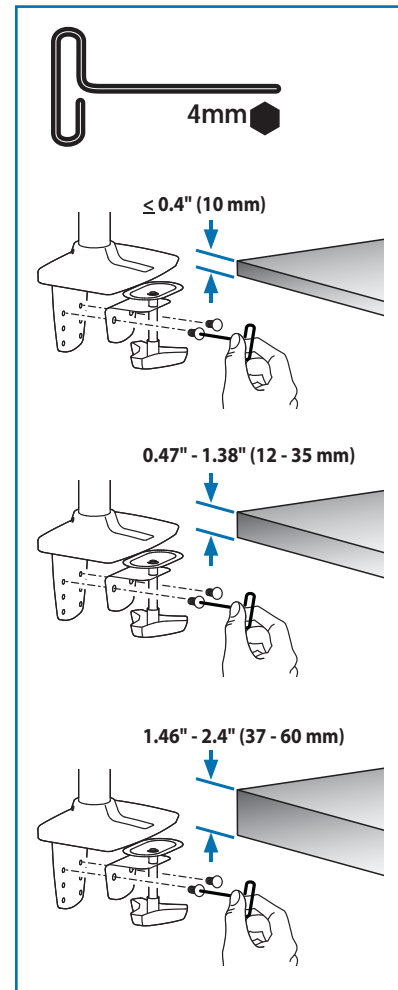
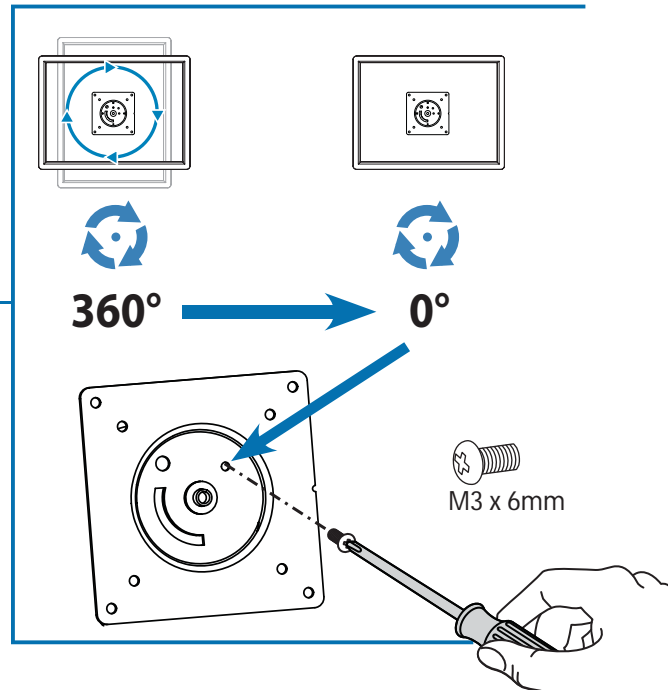
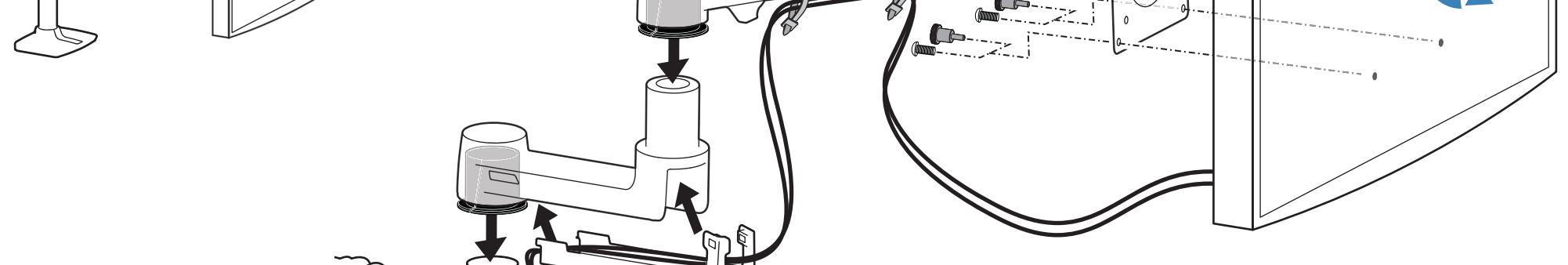
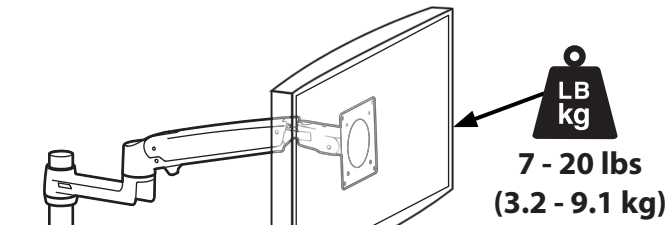

CAUTION: For secure arm attachment and to avoid equipment damage, plate must make contact with underside of desk on both sides of the hole.

Precaución: Para fijar el brazo de forma segura y evitar que el equipo resulte dañado, la placa debe hacer contacto con la cara inferior de la mesa a ambos lados del orificio.

Attention: Pour une fixation au bras sûre et pour éviter que le matériel soit endommagé, la plaque doit être en contact avec le dessous du bureau des deux côtés du trou.

Vorsicht: Um eine sichere Armbefestigung zu gewährleisten und eine Beschädigung des Geräts zu vermeiden, muss die Platte Kontakt mit der Unterseite des Schreibtischs und beiden Seiten des Lochs haben.

Let op: Om de arm stevig te bevestigen en om schade aan de apparatuur te voorkomen, moet de plaat contact maken met de onderkant van het bureau aan beide kanten van de opening.

Attenzione: per fissare bene il braccio e prevenire danni all'attrezzatura, la piastra deve essere a contatto con il lato inferiore del tavolo da entrambi i lati del foro.

注意: アームをしっかり接続し、機器の損傷を防ぐために、プレートは穴の両側で机の下部と接触するようにしてください。

小心: 为了确保支臂安装牢固并避免损坏设备, 安装板在孔的两侧均须与桌面的下侧接触。

Ergotron Limited Warranty

Ergotron warrants that its products will remain free of defects in material and workmanship for five (5) years. All subject to the exceptions, exclusions and limitations as set forth below.

Exceptions to this warranty include:

- Three (3)-year warranty on all Neo-Flex™ by Ergotron products
- StyleView Carts:
- Two (2)-year warranty on all power supply components by Ergotron
- Battery carries an up to a one (1)-year performance warranty (see Limitations below) and six (6)-month warranty against manufacturer's defects. Note: In EU, the warranty against manufacturer's defects is two (2)-years.
- One (1)-year warranty on all electronic non-power supply components (excludes AA batteries)
- OEM products resold by Ergotron are warranted by the respective manufacturer
- Product that is refurbished by Ergotron and sold by Ergotron carries a 90-day warranty
- Thirty (30)-day warranty on all service programs
- Ergotron warranties are nontransferable

Exclusive Remedy: If any Ergotron equipment is or becomes defective in material or workmanship during the warranty period, Ergotron will determine with the customer if the product defect is covered under warranty. Ergotron, at its sole discretion, may replace or repair the unit determined to be under warranty at a designated Ergotron location or at the customer location. The purchaser must get pre-approved authorization to return product to Ergotron. The Purchaser must contact Ergotron to obtain an RMA (Return Material Authorization) number. Ergotron will promptly repair or replace the item and ship it to Purchaser at no charge to the Purchaser. Performance of repair or replacement does not renew or extend the warranty period.

THIS REMEDY IS THE EXCLUSIVE REMEDY FOR BREACH OF WARRANTY AS TO THE EQUIPMENT, except in respect to personal injury. Purchaser shall give Ergotron immediate written notice of any personal injury resulting from use of Ergotron equipment.

Exclusions and Limitations: Ergotron disclaims liability for injuries or losses caused by or associated with installation or use of its equipment in any manner other than in strict conformance with the instructions set forth in its installation manuals, supplemental assembly and installation instruction sheets, technical bulletins or product literature, or by equipment that has been altered, damaged or misused.

Warranty on fully charged batteries left in an unused state for more than three (3) consecutive months is automatically void. Warranty on fully discharged batteries left in an unused state for more than three (3) consecutive days is automatically void.

Two (2)-year warranty on all power supply components by Ergotron; battery carries a 90 day performance warranty and six (6) month warranty against manufacturer's defects. Performance warranty is extended to 1 year on the battery providing:

- StyleLink software is installed and it shows compliance with exclusions and limitations
- Battery is not discharged below 25% capacity more than 25 times
- Battery is fully recharged at least once every 36 hours

Purchaser has not relied upon and Ergotron disclaims any and all warranties other than the expressed warranty stated above, subject to the exclusions and limitations provided herein. Ergotron disclaims all other warranties, expressed or implied, including but not limited to the warranties of merchantability and fitness for a particular purpose. Ergotron further disclaims liability to purchaser and all others for all consequential, incidental and special damages caused by or in connection with the products, their use or misuse, and their performance or nonperformance.

For more information on this product or installation visit:
www.ergotron.com

© 2009 Ergotron, Inc.
 All rights reserved.



Americas Sales and Corporate Headquarters
 St. Paul, MN USA
 (800) 888-8458
 +1-651-681-7600
 www.ergotron.com
 sales@ergotron.com

EMEA Sales
 Amersfoort, The Netherlands
 +31 33 45 45 600
 www.ergotron.com
 info.eu@ergotron.com

APAC Sales
 Tokyo, Japan
 www.ergotron.com
 apaccustomerservice@ergotron.com

Worldwide OEM Sales
 www.ergotron.com
 info.oem@ergotron.com

While Ergotron, Inc. makes every effort to provide accurate and complete information on the installation and use of its products, it will not be held liable for any editorial errors or omissions (including those made in the process of translation from English to another language), or for incidental, special or consequential damages of any nature resulting from furnishing this instruction and performance of equipment in connection with this instruction. Ergotron, Inc. reserves the right to make changes in the product design and/or product documentation without notification to its users. For the most current product information, or to know if this document is available in languages other than those herein, please contact Ergotron. No part of this publication may be reproduced, stored in a retrieval system, or transmitted in any form or by any means, electronic, mechanical, photocopying, recording or otherwise without the prior written consent of Ergotron, Inc., 1181 Trapp Road, Eagan, Minnesota, 55121, USA. Patents Pending and Patented U.S. & Foreign. Ergotron is a registered trademark of Ergotron, Inc.

Adjustment Einstellung 調整
 Ajuste Instellen 调节
 Réglage Regolazione 调节

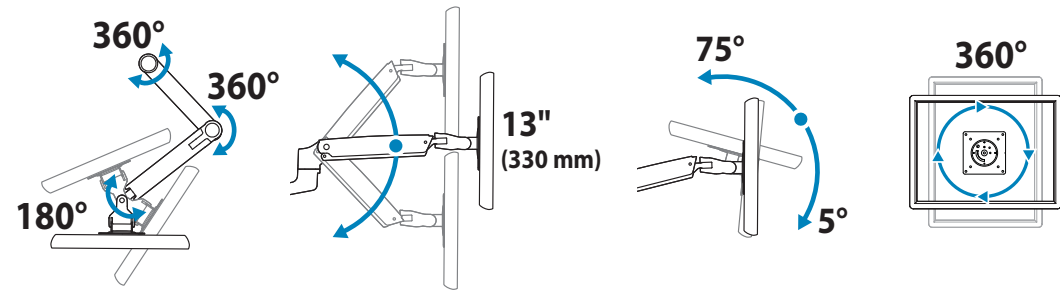

Follow these instructions to tighten or loosen tension.
 Siga estas instrucciones para ajustar o aflojar la tensión.
 Suivez ces instructions pour desserrer ou resserrer la tension.

Befolgen Sie diese Anleitung, um die Spannung zu lockern oder zu verstärken.
 Volg deze instructies om de spanning te vergroten of verkleinen.
 Seguire queste istruzioni per aumentare o ridurre la tensione di bloccaggio.

圧力を増減するには次の手順に従います。
 遵照这些说明拧紧或拧松。

1

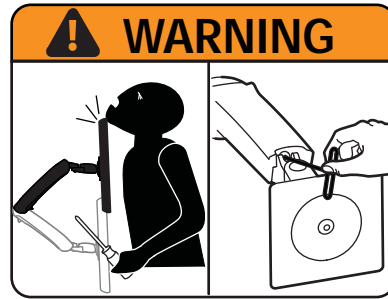
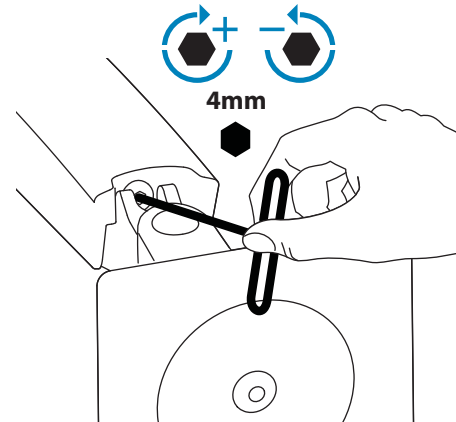
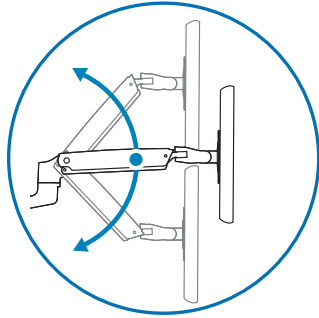

WARNING! Stored Energy Hazard: The arm mechanism is under tension and will move up rapidly, on its own, as soon as attached equipment is removed. For this reason, DO NOT remove equipment unless the arm has been moved to the highest position! Failure to follow this instruction may result in serious personal injury and/or equipment damage!

ADVERTENCIA: Riesgo de energía almacenada: El mecanismo del brazo está bajo tensión y se moverá rápidamente hacia arriba, por sí mismo, tan pronto como se retire el equipo acoplado. Por ello, NO retire el equipo a menos que esté colocado en su posición más elevada. El incumplimiento de esta instrucción puede provocar lesiones personales graves y dañar el equipo.

AVERTISSEMENT! Risque d'énergie accumulée : Le mécanisme du bras est sous tension et se lèvera rapidement, tout seul, dès que le matériel est retiré. Pour cette raison, NE PAS retirer votre matériel à moins que le bras n'ait été mis à la position la plus élevée ! Risque de blessure corporelle et/ou d'endommagement du matériel en cas de non-respect de cette instruction !

WAARSCHUWING! Rischio da energia immagazzinata: il meccanismo del braccio è sotto tensione e si muove rapidamente da sé non appena si toglie l'apparecchiatura a cui è collegato. Per questo motivo, NON rimuovere l'apparecchio a meno che il braccio non sia stata portato sulla posizione più alta. La mancata osservanza di questa precauzione può causare infortuni gravi e/o danni all'apparecchiatura.

WARNUNG! Gefährdung durch gespeicherte Energie: Der Arm-Mechanismus der Arbeitsfläche steht unter Spannung und bewegt sich von allein und schnell nach oben, sobald das befestigte Gerät abgenommen wird. Entfernen Sie aus diesem Grund die Geräte nur, wenn sich der Arm auf der höchsten Position befindet! Eine Missachtung dieser Anweisung kann zu ernsthaften Verletzungen und/oder Beschädigungen am Gerät führen.

AVVERTENZA! Gevaar door opgeslagen energie: het hefmechanisme van het werkoppervlak staat onder spanning en verplaatst zich zelfstandig snel omhoog wanneer de bevestigde apparatuur wordt verwijderd. Verwijder apparatuur daarom ALLEEN nadat de arm in de hoogste stand is gezet! Als u deze instructie niet opvolgt, kan dit tot ernstig persoonlijk letsel en/of beschadiging van de apparatuur leiden!

警告: 蓄積エネルギーの危険: アームメカニズムには張力が作用しており、付属機器を取り外すと自動的に素早く上に跳ね上がります。そのため、付属機器を取り外す前にアームが一番上の位置に移動してください。この指示を無視すると、重大な人体への傷害や機器の損傷を招く恐れがあります。

警告! 储能危险: 支臂机构处于受力状态, 在拆除所安装的设备后会自行快速上升。因此, 在将支臂移到最高位置之前, 不要拆除设备! 不遵守本规定可能导致严重的人身伤害和/或设备损坏!



CAUTION: DO NOT overtighten fasteners. Overtightening may cause damage to your equipment.

Cuidado: No sobreapriete los tornillos, pues podría causar un daño al equipo.

Attention: ne forcez pas le serrage de la vis, cela pourrait endommager l'écran et/ou les attaches.

Warnung: Zu festes Anziehen der Schrauben kann zu Beschädigungen führen.

Let op: draai de schroeven niet te strak aan. Te strak aandraaien kan schade veroorzaken aan uw apparatuur.

Attenzione: Non stringere eccessivamente i dispositivi di fissaggio. Ciò potrebbe causare danni all'apparecchiatura.

注意: 調節ネジは締めすぎないようにしてください。強く締め付けすぎると、器具が破損する原因となります。

小心: 不要过度拧紧固定器。过度拧紧可能会损坏设备。

가

!

:

!

가

!

가

2

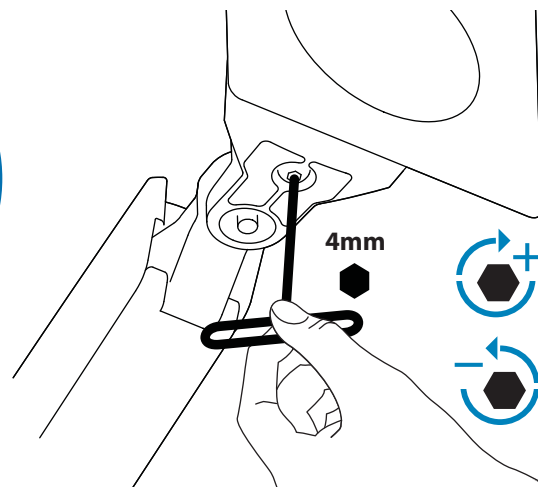
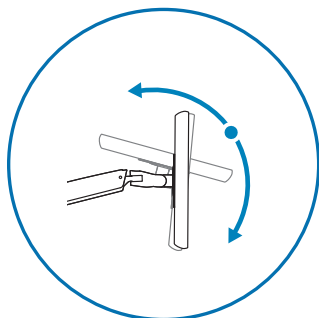

CAUTION: DO NOT remove screw. Removing screw may cause damage to equipment.

Cuidado: NO quite el tornillo! Quitar el tornillo puede causar daños en el equipamiento.

Attention: N'ENLEVEZ PAS la vis ! Enlever la vis pourrait endommager votre équipement.

Achtung: Bitte entfernen Sie unter keinen Umständen die Stellschraube. Das Entfernen dieser Stellschraube führt zu Beschädigungen an Schwenkarm und Monitor.

Let op: verwijder GEEN schroeven! Het verwijderen van schroeven kan schade aan de apparatuur veroorzaken.

Attenzione: NON rimuovere le viti! Ciò potrebbe causare danno all'apparecchiatura.

注意: ネジは取り外さないようにしてください。ネジを取り外すと、器具が破損する原因となります。

小心: 不要拆除螺丝。拆除螺丝可能会损坏设备。

가

3

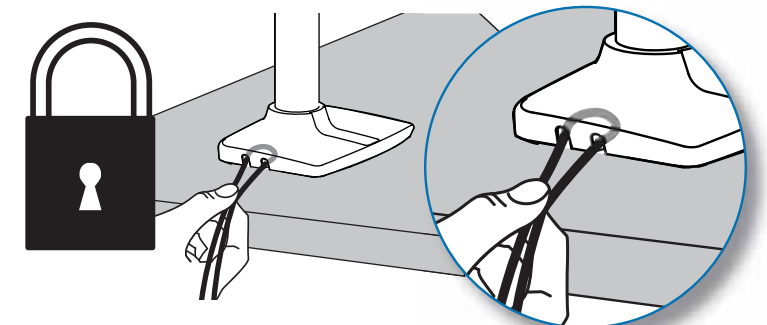
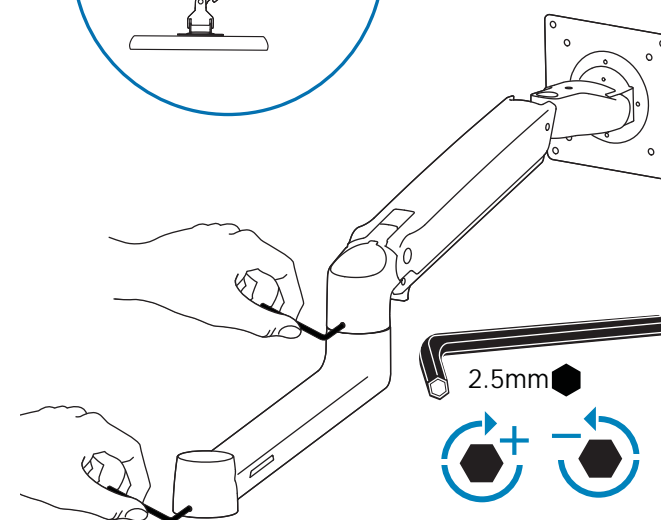
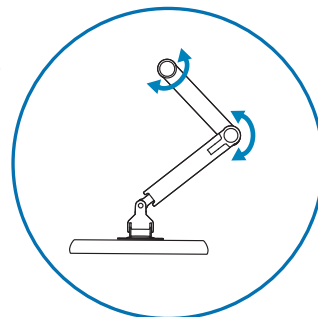

www.ergotron.com
 USA 1-800-888-8458
 Europe +31 (0)33-45 45 600
 China 86-769-86018920