

www.ergotron.com
 USA 1-800-888-8458
 Europe +31 (0)33-45 45 600
 China 86-769-86018920

For service and warranty visit www.ergotron.com
 Si desea información de servicio y garantía, visite www.ergotron.com
 Pour toute question concernant la garantie ou le service client, consultez www.ergotron.com
 Weitere Informationen zu Service und Gewährleistung erhalten Sie unter www.ergotron.com.
 Ga voor service en garantie naar www.ergotron.com
 Per assistenza e la garanzia visitate www.ergotron.com
 Gå in på www.ergotron.com för service och garanti
 サービスおよび保証について詳しくは、www.ergotron.com をご覧ください。
 有关服务和保修，请访问 www.ergotron.com

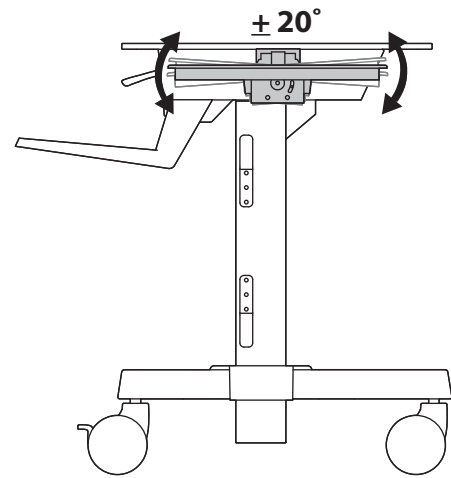

	A	B	C	D	E
1	1x 	1x 	5-sided wrench llave pentagonal Clef Allen Inbusschlüssel 4mm 5-kantige sleutel Chiave a 5 lati 5 角レンチ 5角扳手 5 1x 4mm 1x 5mm 1x 6mm	1x M6 x 26mm	1x
2	2x 	1x 		1x M4 x 6mm	4x M5 x 8mm

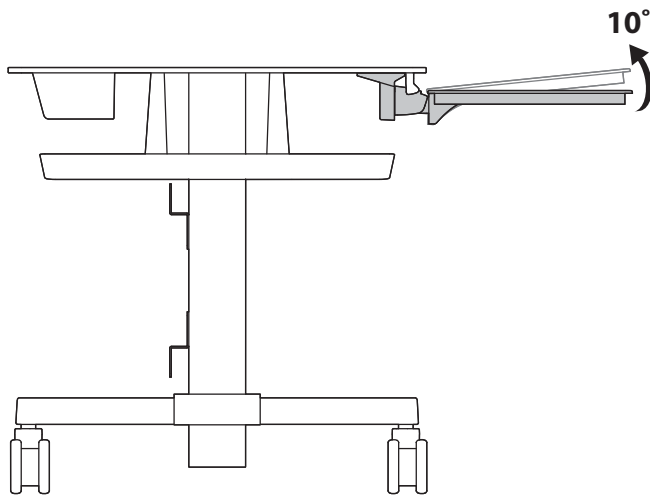
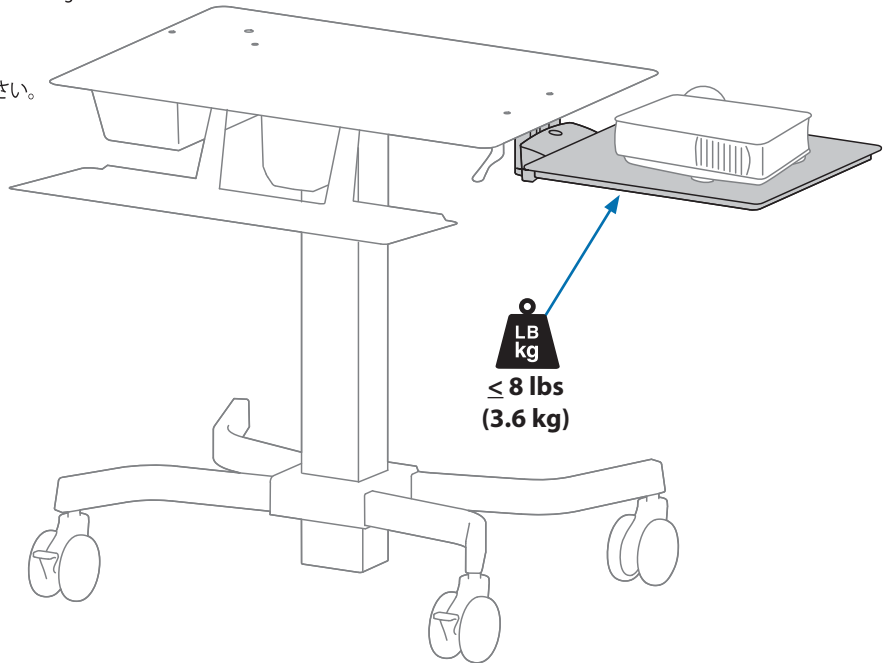
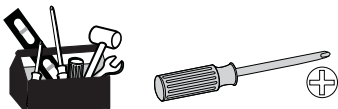

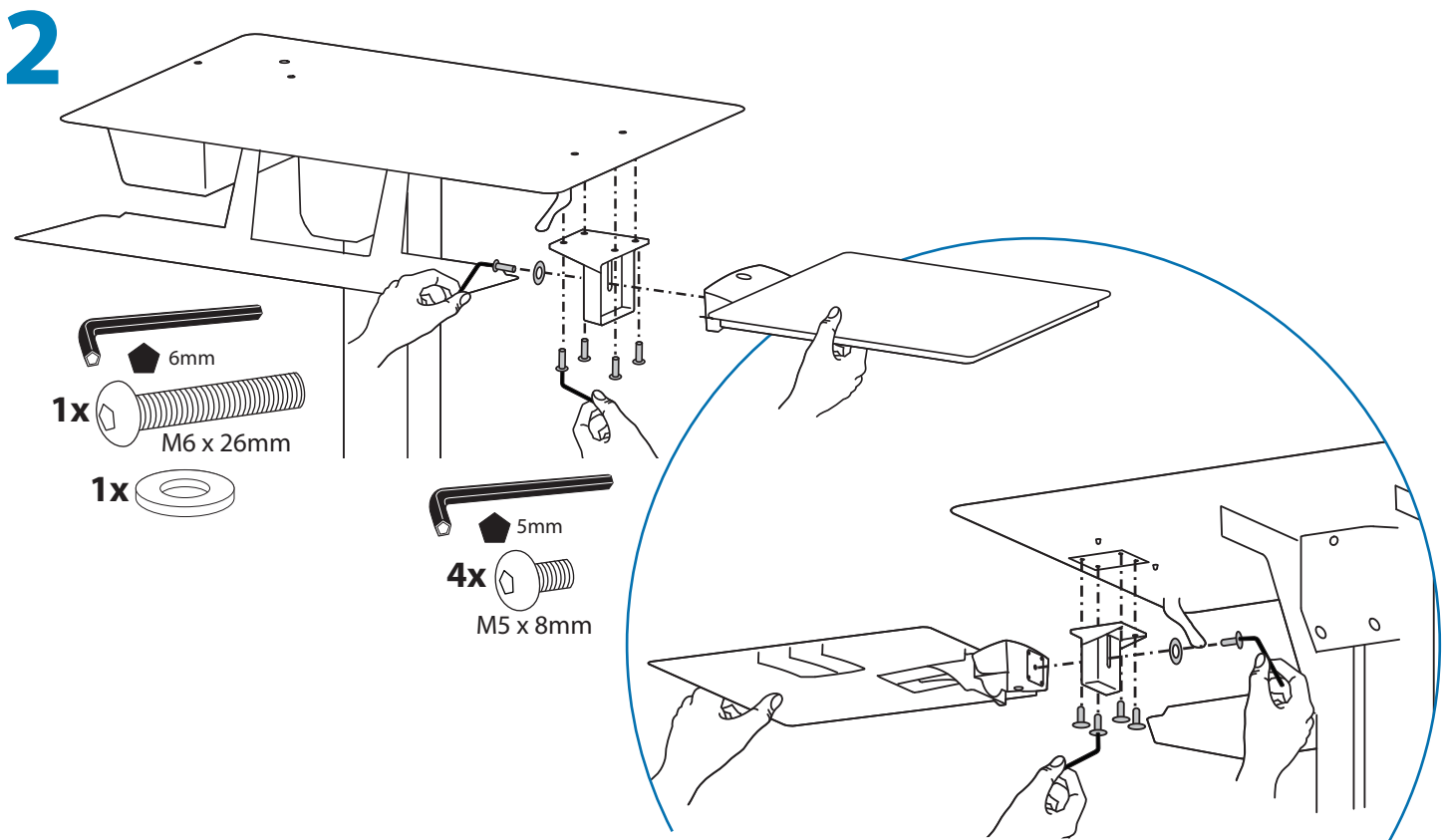
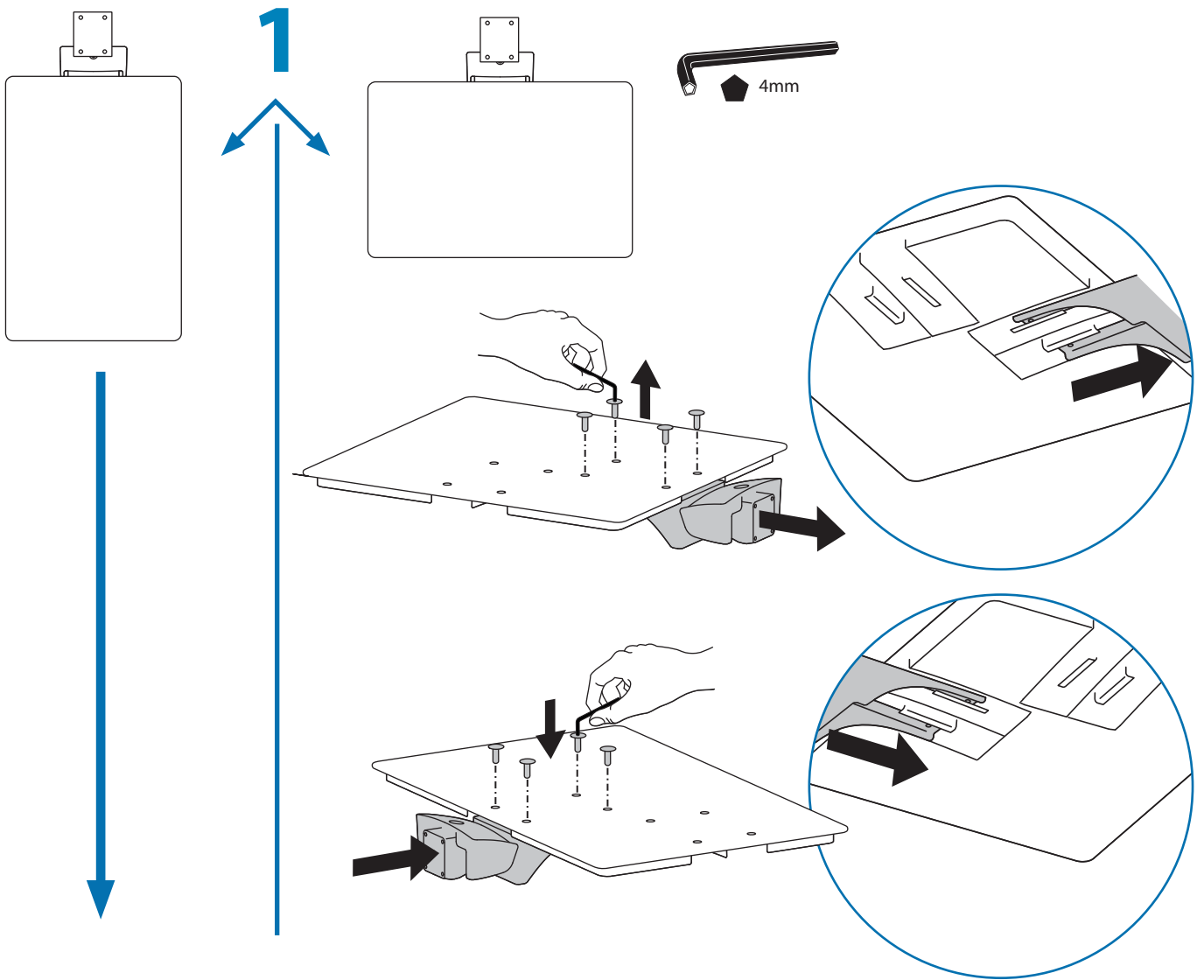

3

1x

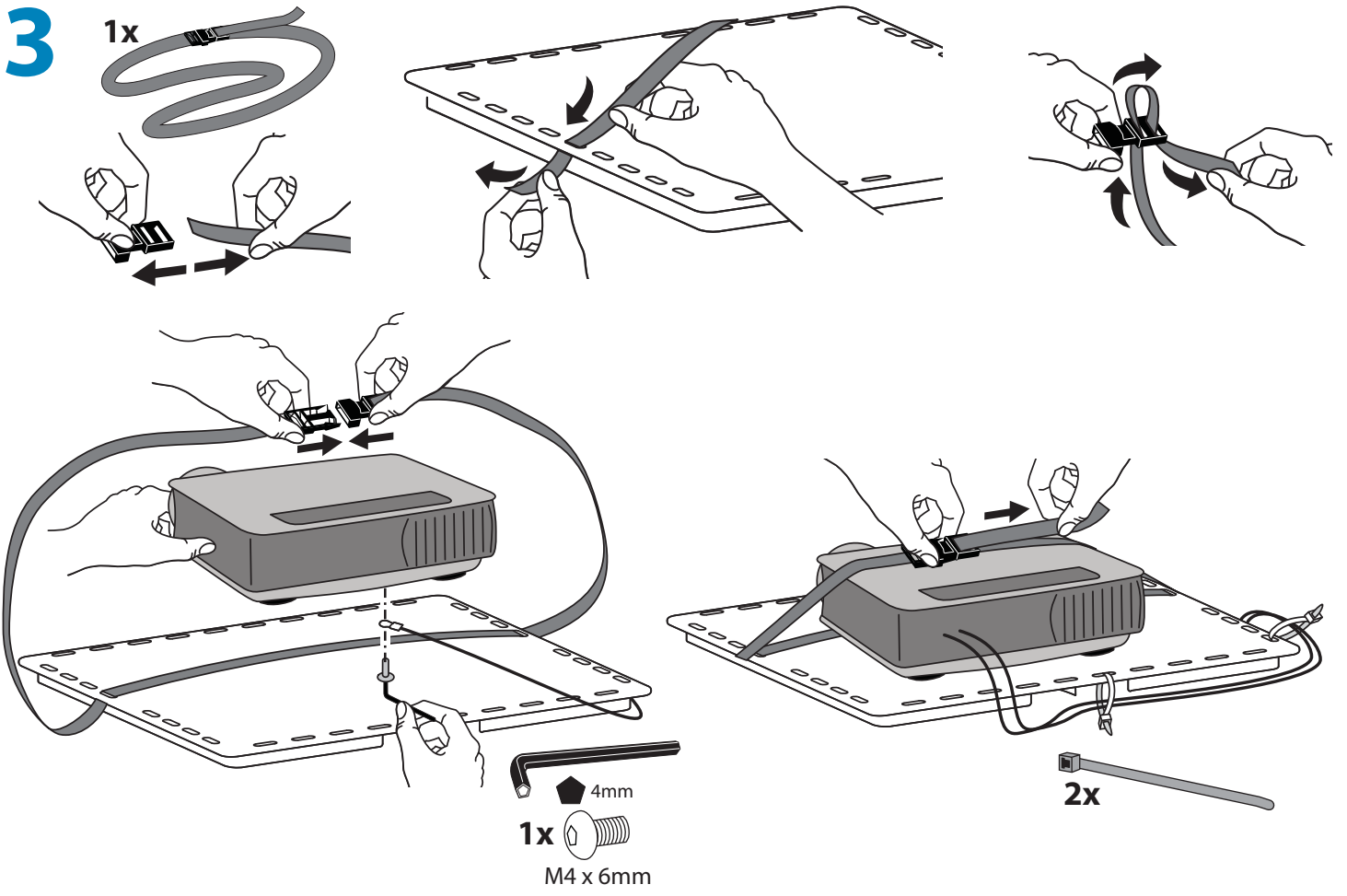

4

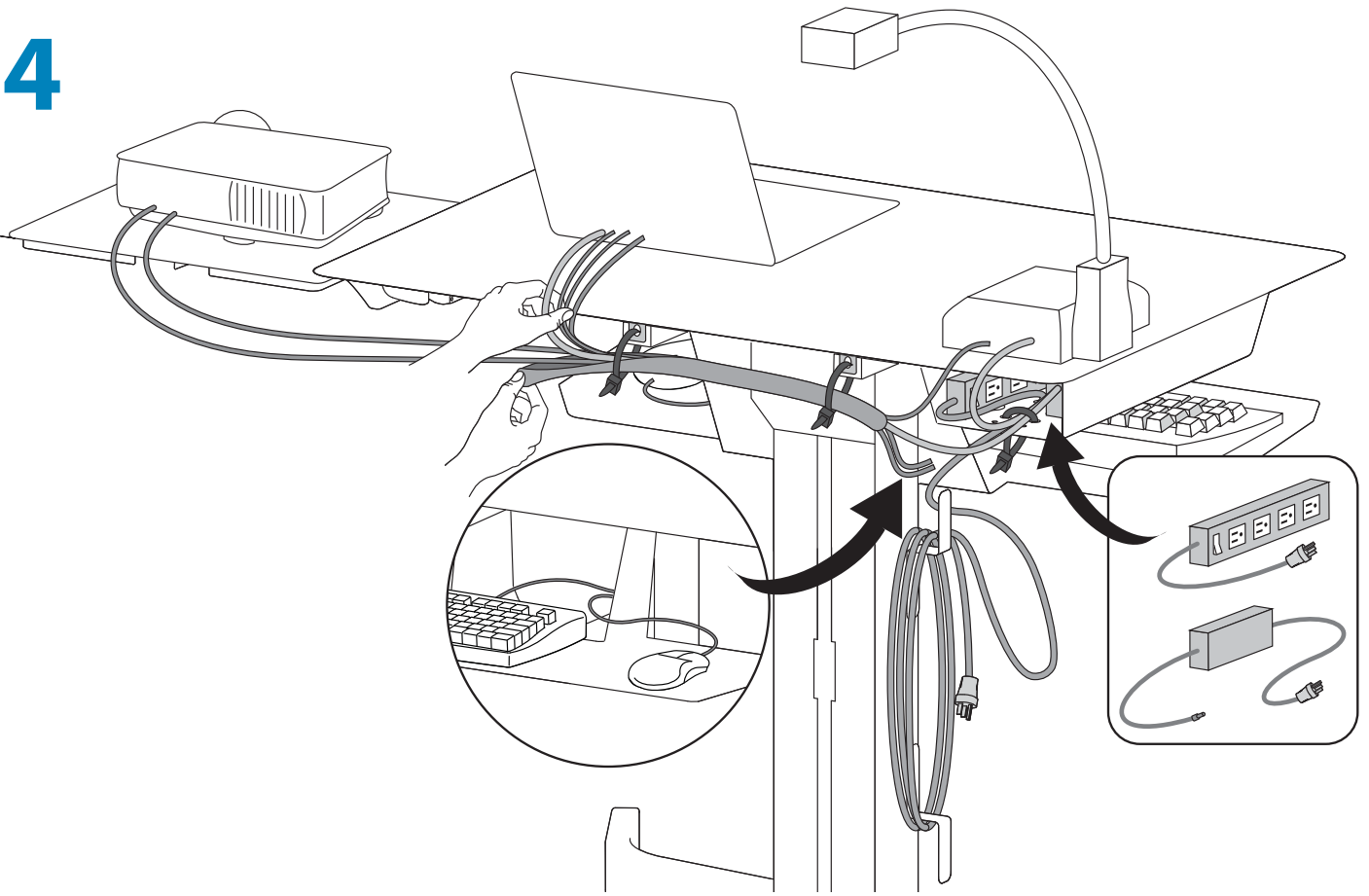

5 Adjustment · Ajuste · Réglage · Einstellung · Instellen · Regolazione · 調整 · 调节 ·



Adjust your mounting solution to handle the added weight.

Adjustments should move smoothly and easily through the full range of motion and stay where you set it. If adjustments are difficult and do not stay in the desired position, follow the instructions to loosen or tighten the tension to create a smooth, easy adjustment motion. Depending on your product and the adjustment, it may take several turns to notice a difference.

Adjust your mounting solution to handle the added weight.

Los movimientos de ajuste deben poder realizarse de manera suave y firme dentro de la amplitud de movimiento permitida, y mantenerse donde usted los fije. Si los ajustes son abruptos o no permanecen en dicha posición, siga las instrucciones para aflojar o ajustar la tensión y suavizar así el movimiento. Dependiendo del producto y el ajuste, es posible que deba hacer varios intentos hasta poder observar la diferencia.

Adjust your mounting solution to handle the added weight.

Les réglages doivent s'effectuer facilement et sans forcer dans toutes les positions et rester en place une fois réalisés. Si les réglages sont difficiles à effectuer et ne restent pas en position, suivez les instructions pour desserrer ou resserrer la tension afin que les mouvements soient plus aisés. Selon le produit que vous utilisez et le réglage, il faut parfois effectuer plusieurs tours de vis avant de remarquer une différence.

Adjust your mounting solution to handle the added weight.

Einstellungen sollten über den gesamten Verstellbereich gleichmäßig und leicht durchzuführen sein und an der eingestellten Position verbleiben. Lassen sich die Einstellungen nur schwer durchführen oder bleibt das Gerät nicht in der gewünschten Position, folgen Sie der Anleitung und lockern oder verstärken Sie die Spannung für eine gleichmäßige und leichte Einstellung. Je nach Produkt und Einstellung muss dies mehrmals wiederholt werden, um einen Unterschied zu merken.

Adjust your mounting solution to handle the added weight.

Verplaatsingen moeten soepel en eenvoudig over het volle bewegingsbereik mogelijk zijn, en de ingestelde positie moet gehandhaafd blijven. Als aanpassingen moeilijk zijn en de gewenste positie blijft niet gehandhaafd, dan volgt u de instructies om de spanning te verminderen of vergroten om een soepele, eenvoudige aanpassing mogelijk te maken. Al naargelang uw product en de gewenste aanpassing, kunnen een paar slagen nodig zijn om verschil te merken.

Adjust your mounting solution to handle the added weight.

I componenti a posizione regolabile devono essere spostabili in modo regolare e agevolmente per la loro intera corsa e rimanere fermi quando li si rilasciano. Se risulta difficile regolare la posizione di un componente o questo non rimane nella posizione desiderata, seguire le istruzioni per ridurre o aumentare la tensione di bloccaggio affinché il movimento risulti agevole e facilmente regolabile. A seconda del prodotto e del tipo di regolazione, possono essere necessarie più corse prima di notare una differenza.

Adjust your mounting solution to handle the added weight.

Justeringar ska röra sig smidigt och lätt genom hela uppsättningen rörelser, och stanna där du ställer in dem. Om justeringarna är besvärliga och inte stannar i önskad position, följ instruktionerna om att lossa på eller skruva åt skruvar för att skapa en smidig och lätt justeringsrörelse. Beroende på din produkt, och på justeringen, kan det ta flera varv innan man märker någon skillnad.

Adjust your mounting solution to handle the added weight.

調整は可動域内でスムーズかつ簡単に動く必要があり、選定した位置にしっかり固定されなければなりません。調整の動きがぎこちなく、選定位置で固定されない場合は、調整がスムーズにできるよう、説明書に従って張力を増減します。お使いの製品や調整によっては、違いがはっきりするまで何回か回さなければならないこともあります。

Adjust your mounting solution to handle the added weight.

根据您所用产品及调节方式，可能需要旋转几圈后才能注意到差别。

A

10°

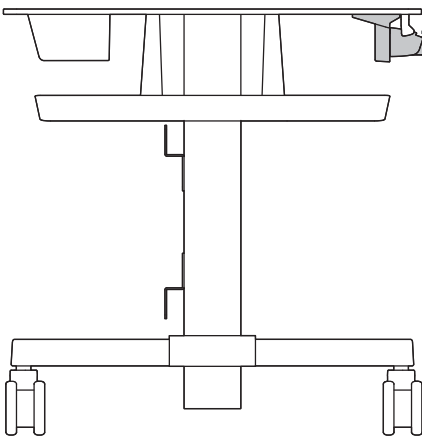

Follow these instructions to tighten or loosen tension.

Siga estas instrucciones para ajustar o aflojar la tensión.

Suivez ces instructions pour desserrer ou resserrer la tension.

Befolgen Sie diese Anleitung, um die Spannung zu lockern oder zu verstärken.

Volg deze instructies om de spanning te vergroten of verkleinen.

Seguire queste istruzioni per aumentare o ridurre la tensione di bloccaggio.

压力を増減するには次の手順に従います。

遵照这些说明拧紧或拧松。

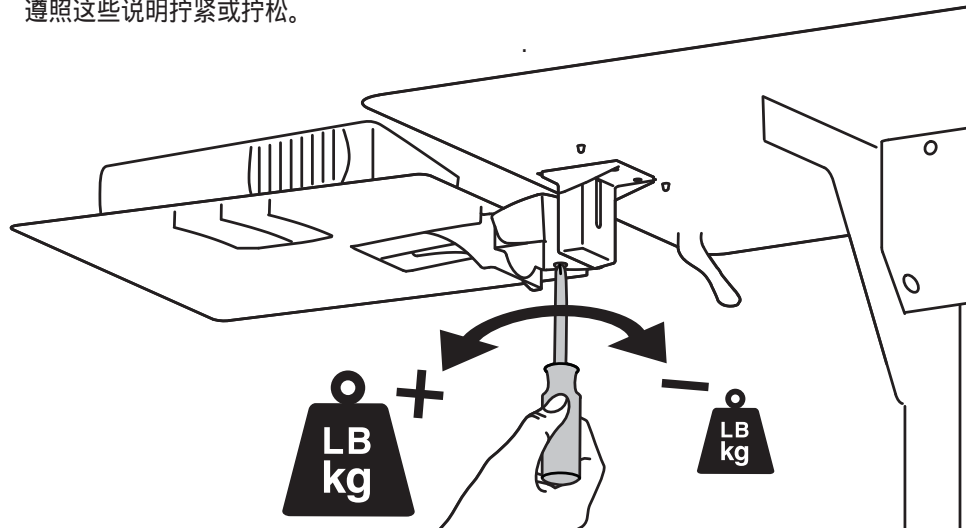
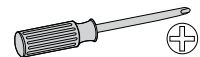

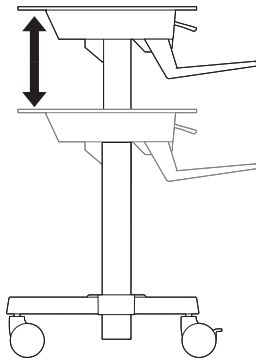
B

Follow these instructions to tighten or loosen tension.
 Siga estas instrucciones para ajustar o aflojar la tensión.
 Suivez ces instructions pour desserrer ou resserrer la tension.
 Befolgen Sie diese Anleitung, um die Spannung zu lockern oder zu verstärken.
 Volg deze instructies om de spanning te vergroten of verkleinen.
 Seguire queste istruzioni per aumentare o ridurre la tensione di bloccaggio.
 压力を増減するには次の手順に従います。
 遵照这些说明拧紧或拧松。

! WARNING

14mm (9/16")

IMPACT HAZARD!
 MOVING PARTS CAN CRUSH AND CUT.

Minimize Lift Tension BEFORE:

- Removing Mounted Equipment.
- Shipping Cart
- Storing Cart

To Minimize Lift Tension

1. Lower worksurface to lowest position.
2. Turn adjustment nut at bottom of riser counterclockwise until it stops (Adjustment may require 40-60 revolutions).

Failure to heed this warning may result in serious personal injury or property damage!
 For More information and instructions refer to product guide at: www.ergotron.com or contact Ergotron Customer Care at 1-800-888-8458. 822-634

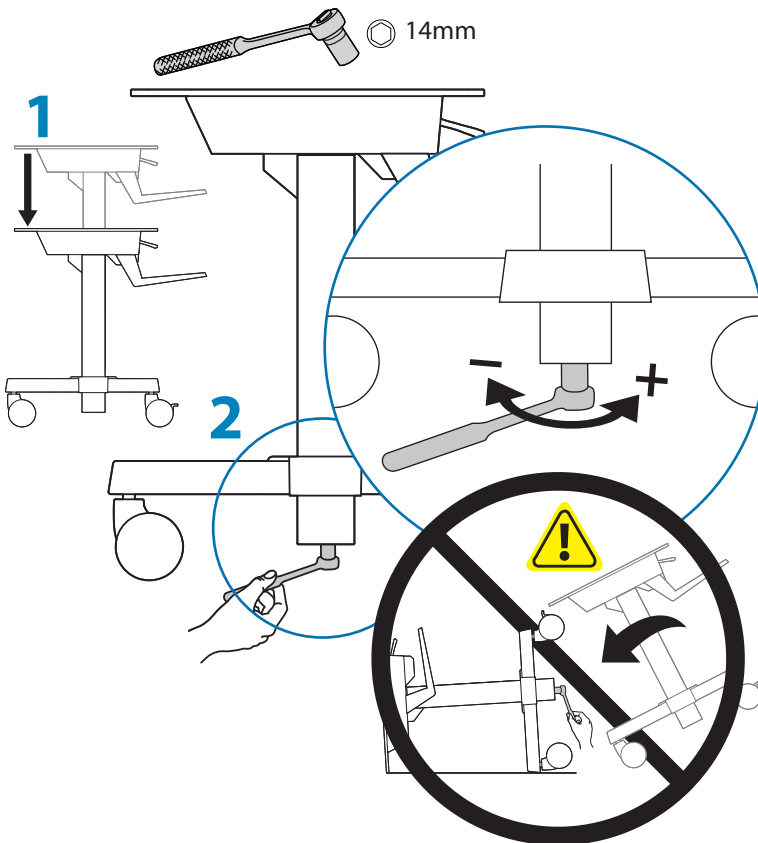

© 2011 Ergotron, Inc.
 All rights reserved.

While Ergotron, Inc. makes every effort to provide accurate and complete information on the installation and use of its products, it will not be held liable for any editorial errors or omissions (including those made in the process of translation from English to another language), or for incidental, special or consequential damages of any nature resulting from furnishing this instruction and performance of equipment in connection with this instruction. Ergotron, Inc. reserves the right to make changes in the product design and/or product documentation without notification to its users. For the most current product information, or to know if this document is available in languages other than those herein, please contact Ergotron. No part of this publication may be reproduced, stored in a retrieval system, or transmitted in any form or by any means, electronic, mechanical, photocopying, recording or otherwise without the prior written consent of Ergotron, Inc., 1181 Trapp Road, Eagan, Minnesota, 55121, USA Patents Pending and Patented U.S. & Foreign. Ergotron is a registered trademark of Ergotron, Inc.

Americas Sales and Corporate Headquarters

St. Paul, MN USA
 (800) 888-8458
 +1-651-681-7600
www.ergotron.com
sales@ergotron.com

EMEA Sales

Amersfoort, The Netherlands
 +31 33 45 45 600
www.ergotron.com
info.eu@ergotron.com

APAC Sales

Tokyo, Japan
www.ergotron.com
apaccustomerservice@ergotron.com

Worldwide OEM Sales

www.ergotron.com
info.oem@ergotron.com