

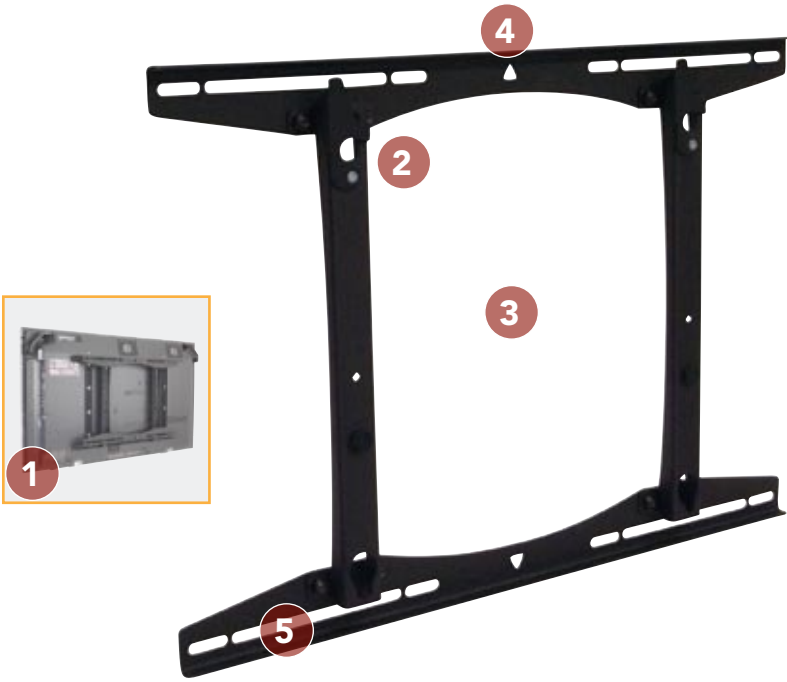

FIXED WALL MOUNTS PST™ □ 42 - 71" WALL MOUNT



FEATURES

- 1 LOW PROFILE**
Designed to ensure mount remains concealed behind the screen.
- 2 Q-LATCH™ MOUNTING SYSTEM**
Flat panel secures to mount with a latching flag. Easy to connect/disconnect – no tools needed! Protect display by adding a padlock.
- 3 OPEN WALL PLATE DESIGN**
Expanded wall plate opening provides cable access and reduces risk of outlet interference.
- 4 RAPID LEVELING™**
Hands-free leveling of mount on wall after installation.
- 5 INTEGRATED LATERAL SHIFT**
Reposition mount 4" (102 mm) left or right after installation for ultimate positioning flexibility.

WHAT YOU NEED TO KNOW

ORDERING OPTIONS
Available in custom or universal.

OTHER PRODUCT OPTIONS



PSH2000™
Heavy-Duty, Fixed Wall Mount
– For flat panels over 65" or 200+ lbs



PST16™
Portrait/Landscape, Fixed Wall Mount

SPECIFICATIONS

Depth from Wall*	1.21" (31 mm)
Lateral Shift	4" (102 mm) Left/Right
Mounts on Studs	16", 20", 24" on-center
Dimensions* (HxWxD)	18.38" x 26" x 1.31" (467 x 660 x 33 mm)
Color	Black
Weight Capacity	200 lbs (90.7 kg)

* Dimensions don't include interface bracket



RECOMMENDED ACCESSORIES



PACCC1 ■ Center Channel Speaker Adapter



PAC510 ■ Retro-Fit, Pre-Wire Box



PACPC1 ■ Power Filter

TECHNICAL DRAWINGS

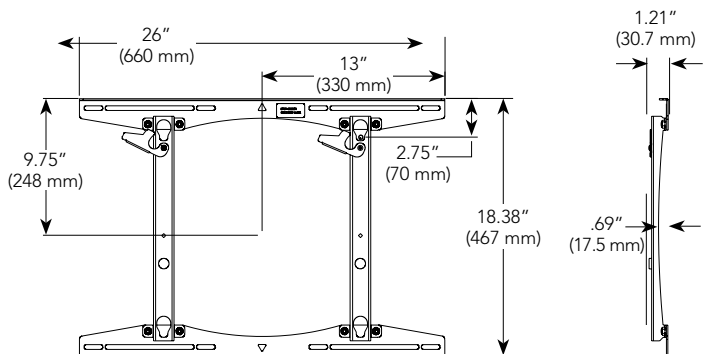

For a complete list of flat panel mount accessories see page 69.