

INSTALLATION INSTRUCTIONS

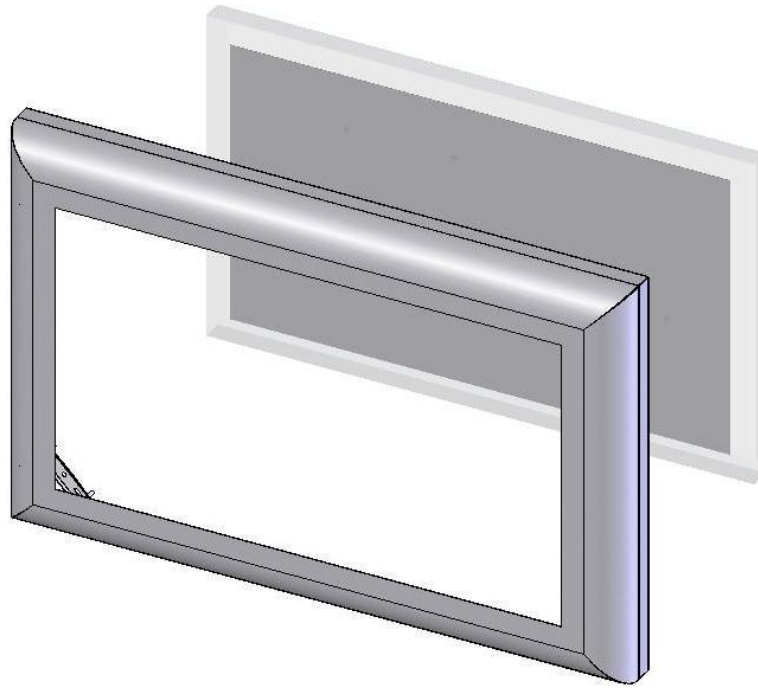

DISPLAY COVER ACCESSORY

DISCLAIMER

CSAV, Inc., and its affiliated corporations and subsidiaries (collectively, "CSAV"), intend to make this manual accurate and complete. However, CSAV makes no claim that the information contained herein covers all details, conditions or variations, nor does it provide for every possible contingency in connection with the installation or use of this product. The information contained in this document is subject to change without notice or obligation of any kind. CSAV makes no representation of warranty, expressed or implied, regarding the information contained herein. CSAV assumes no responsibility for accuracy, completeness or sufficiency of the information contained in this document.



WARNING: Failure to read, thoroughly understand, and follow all instructions can result in serious personal injury, damage to equipment, or voiding of factory warranty! It is the installer's responsibility to make sure all components are properly assembled and installed using the instructions provided.



WARNING: Failure to provide adequate structural strength for this component can result in serious personal injury or damage to equipment! It is the installer's responsibility to make sure the structure to which this component is attached can support five times the combined weight of all equipment. Reinforce the structure as required before installing the component.



WARNING: Exceeding the weight capacity can result in serious personal injury or damage to equipment! It is the installer's responsibility to make sure the combined weight of all components does not exceed the weight limitations of the mount to which it is attached.

The DGP32 weighs 35 lbs (15.88 kg)

The DGP42 weighs 40 lbs (18.14 kg)

The DGP50 weighs 75 lbs (34.02 kg)

IMPORTANT WARNINGS AND CAUTIONS!



WARNING: A WARNING alerts you to the possibility of serious injury or death if you do not follow the instructions.



CAUTION: A CAUTION alerts you to the possibility of damage or destruction of equipment if you do not follow the corresponding instructions.

DIMENSIONS

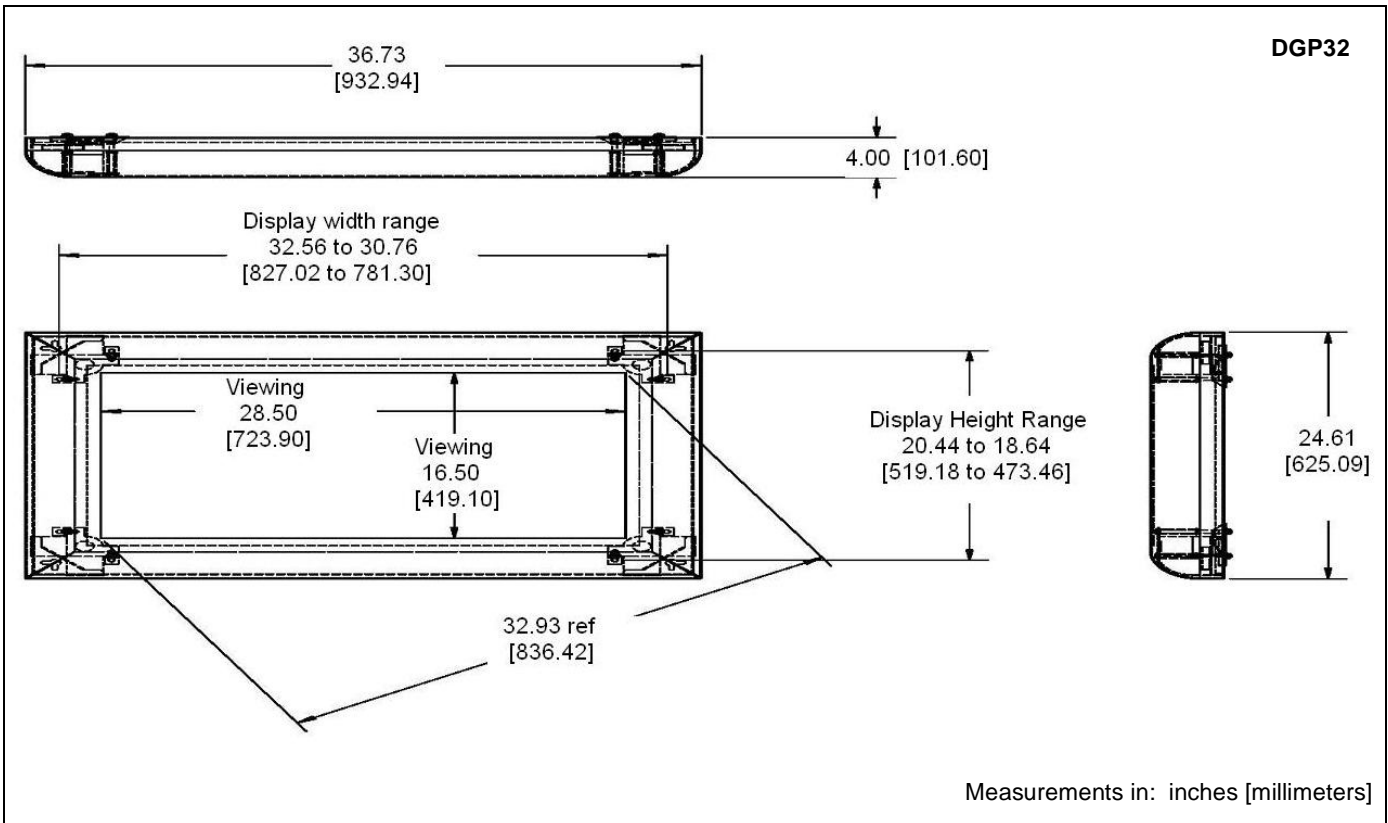

DIMENSIONS

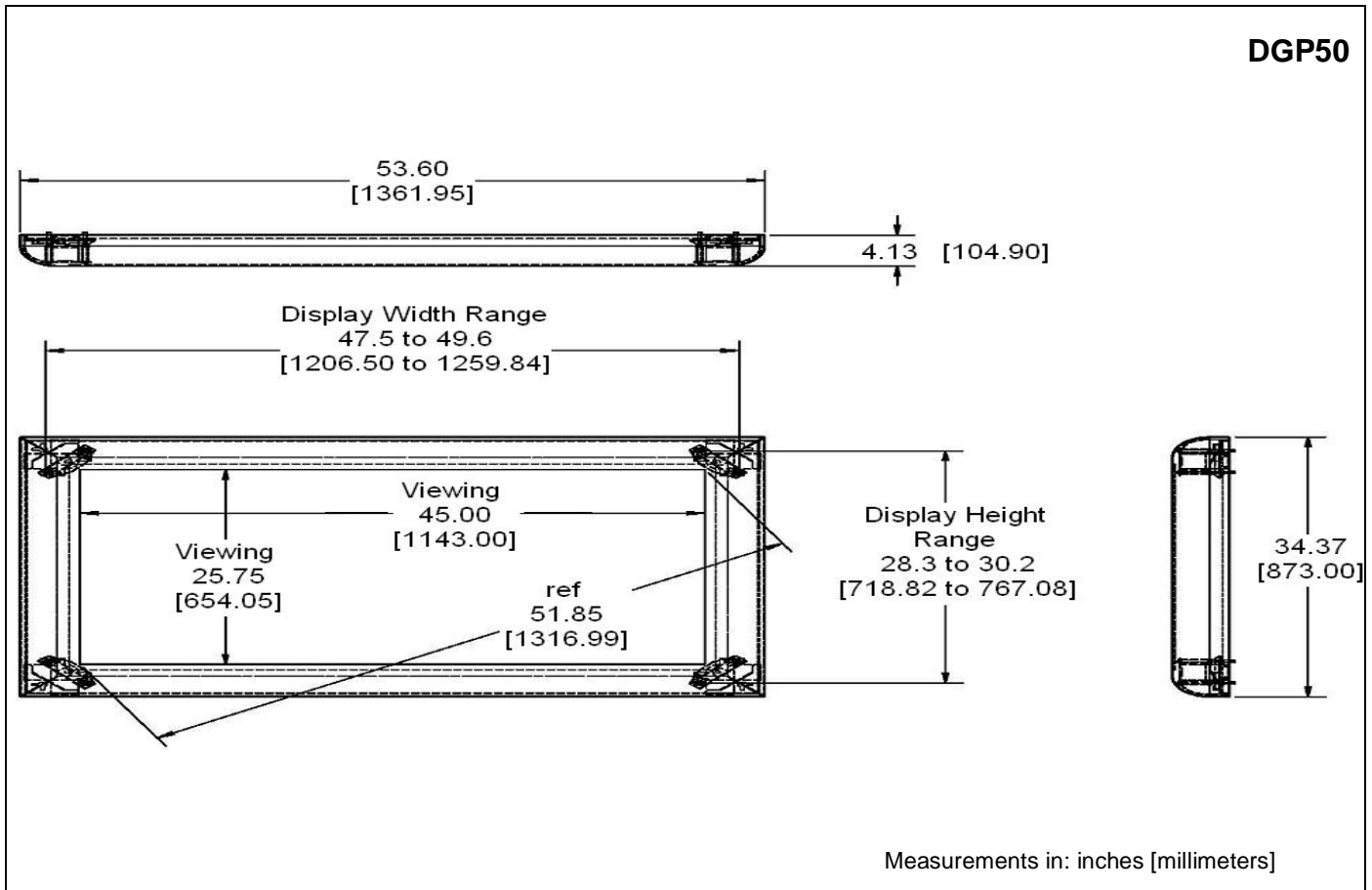
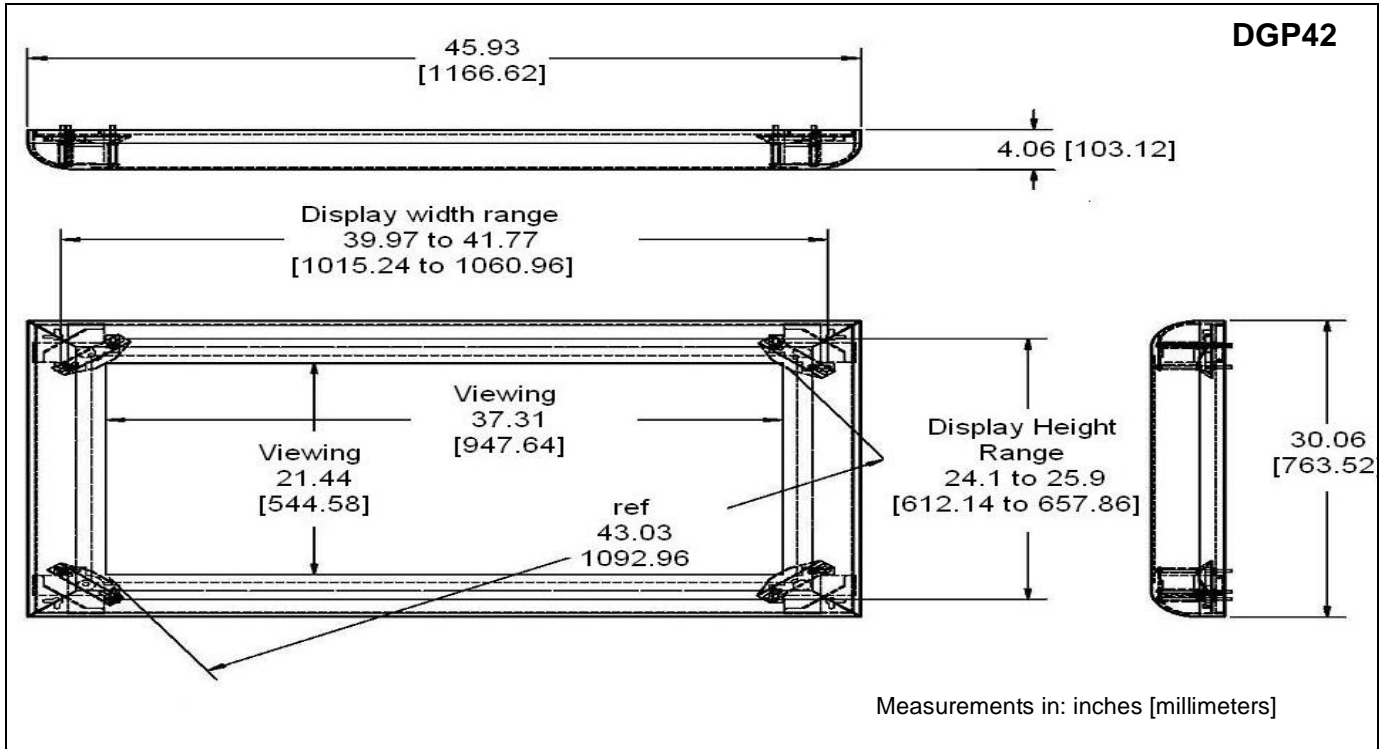

LEGEND

	Open-Ended Wrench
	Llave de boca
	Gabelschlüssel
	Chave de bocas
	Chiave a punte aperte
	Steeksleutel
Clé à fourche	

TOOLS REQUIRED FOR INSTALLATION

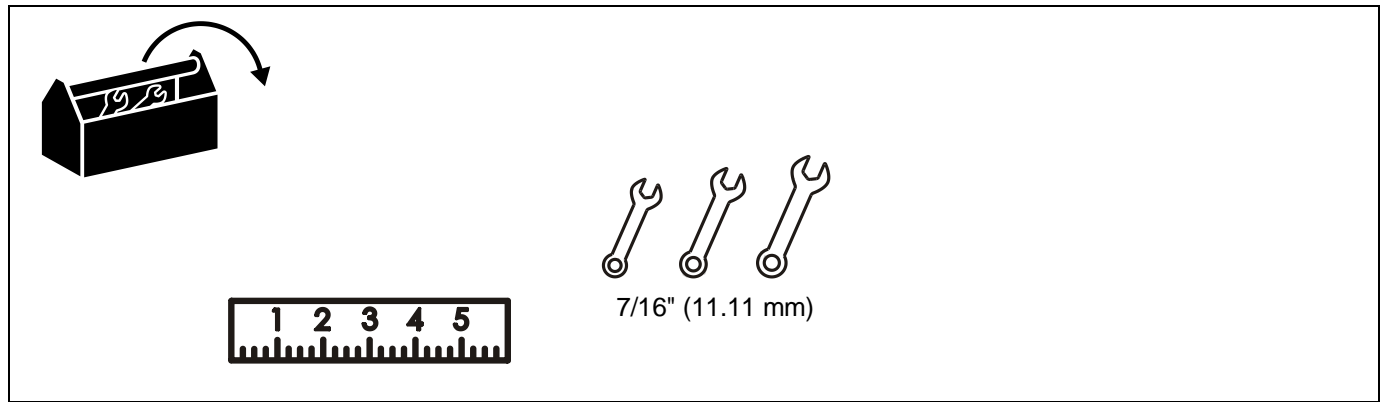

PARTS

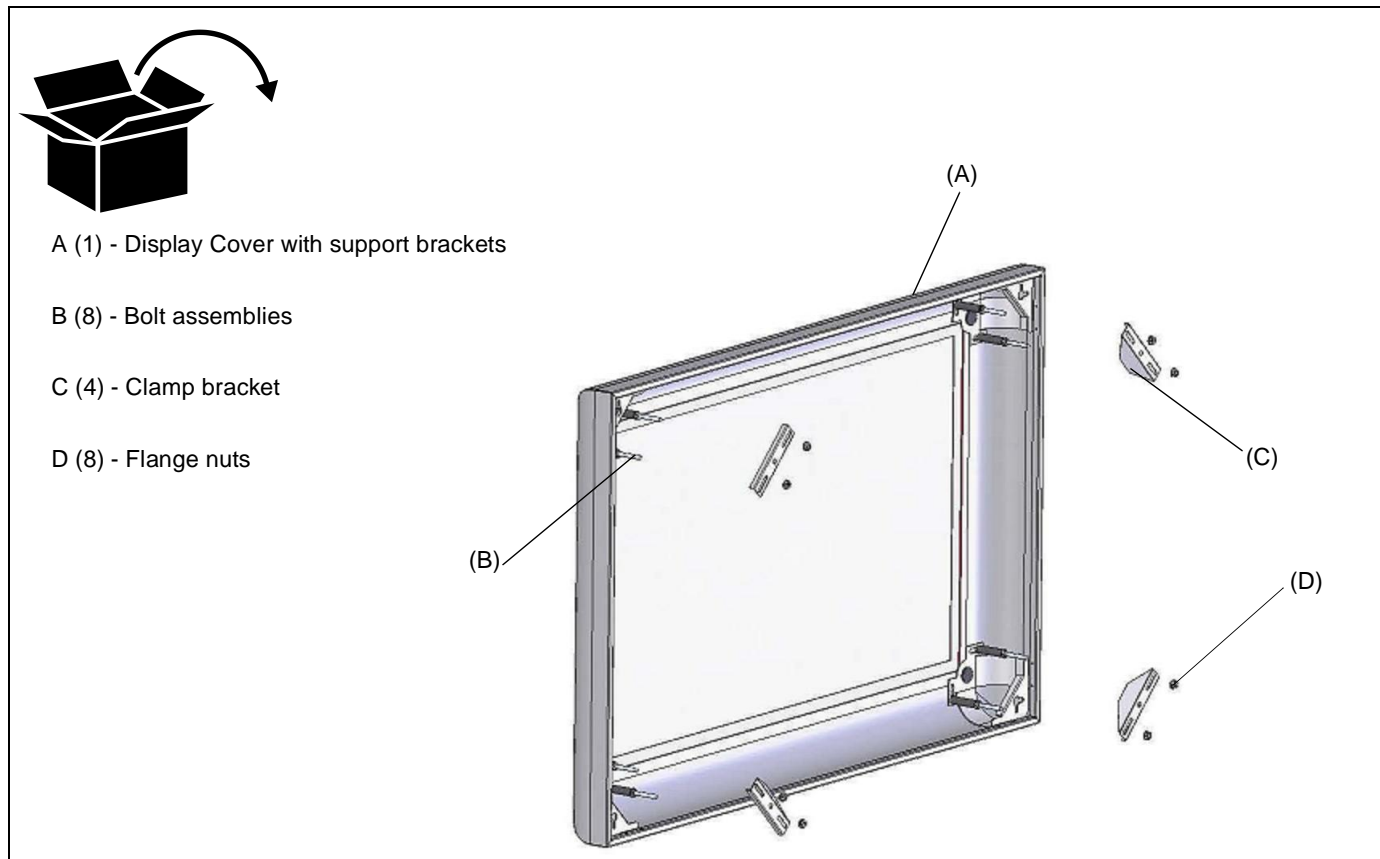

Assembly And Installation



CAUTION: Overheating may cause damage or display failure. Use correct size display cover to allow air circulation around and behind display to prevent overheating.

NOTE: Access to back of display is necessary for installation of DGP display cover.

Adjusting Display Cover Size

1. Measure height and width of display.
2. Loosen and remove flange nuts (D) and padded tubes on bolt assemblies (B). (See Figure 1)

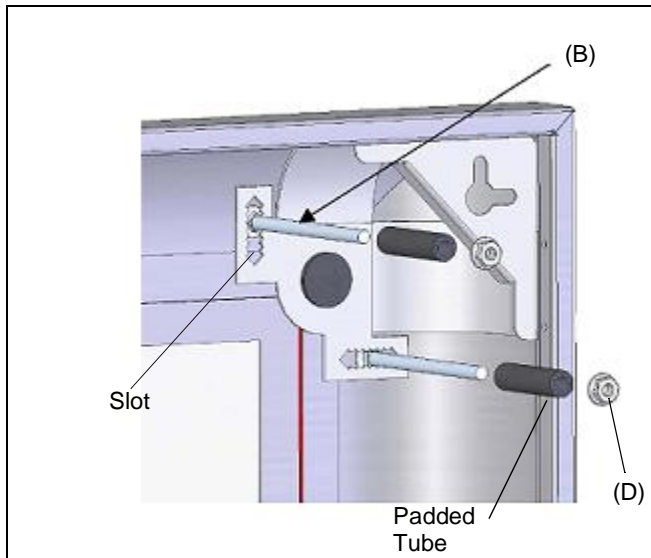

Figure 1

3. Adjust and position bolts (B) into the slots which provide the correct spacing.

NOTE: Engage base of bolts at top of cover in the slot notches. Base of bolts on sides and bottom of cover should be parallel to the slots. (See Figure 2)

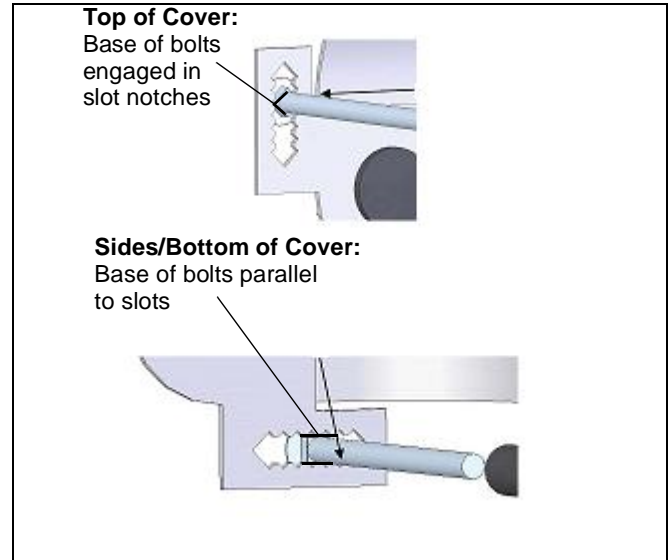

Figure 2

4. Position bolts and tighten the flange nuts securely against the padded tubes. (See Figure 1)
5. Place cover on display.

NOTE: Sponge bumpers and padded bolts may be used to prevent scratches on display.

6. Check display alignment and adjust as necessary.
7. Install clamp brackets (C) over the bolt ends (B). (See Figure 3)

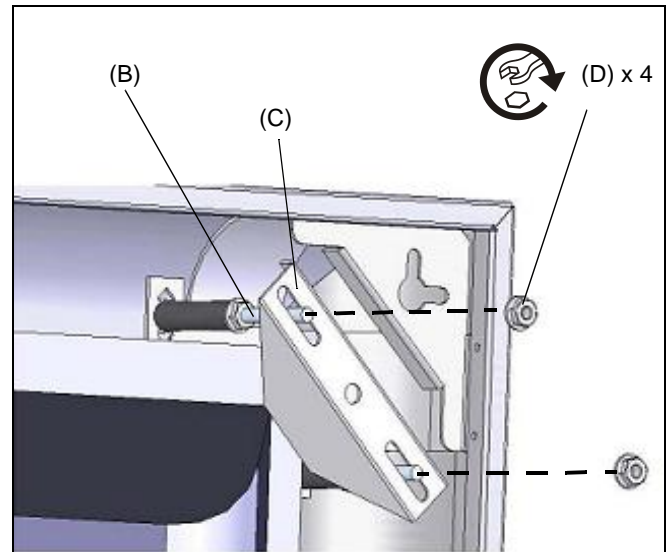

Figure 3

8. Secure with flange nuts (D).

NOTE: Clamps may be rotated to best fit cover to display.



8831-000014
©2007 Chief Manufacturing
www.chiefmfg.com
03/07

USA/International	A 8401 Eagle Creek Parkway, Savage, MN 55378 P 800.582.6480 / 952.894.6280 F 877.894.6918 / 952.894.6918
Europe	A Fellenoord 130 5611 ZB EINDHOVEN, The Netherlands P +31 (0)40 2668620 F +31 (0)40 2668615
Asia Pacific	A Room 30I, Block D, Lily YinDu International Building LuoGang, BuJi Town, Shenzhen, CHINA. Post Code: 518112 深圳市布吉罗岗百合银都国际大厦D栋30I P +86-755-8996 9226 ; 8996 9236 ; 8996 9220 F +86-755-8996 9217