

INSTALLATION INSTRUCTIONS

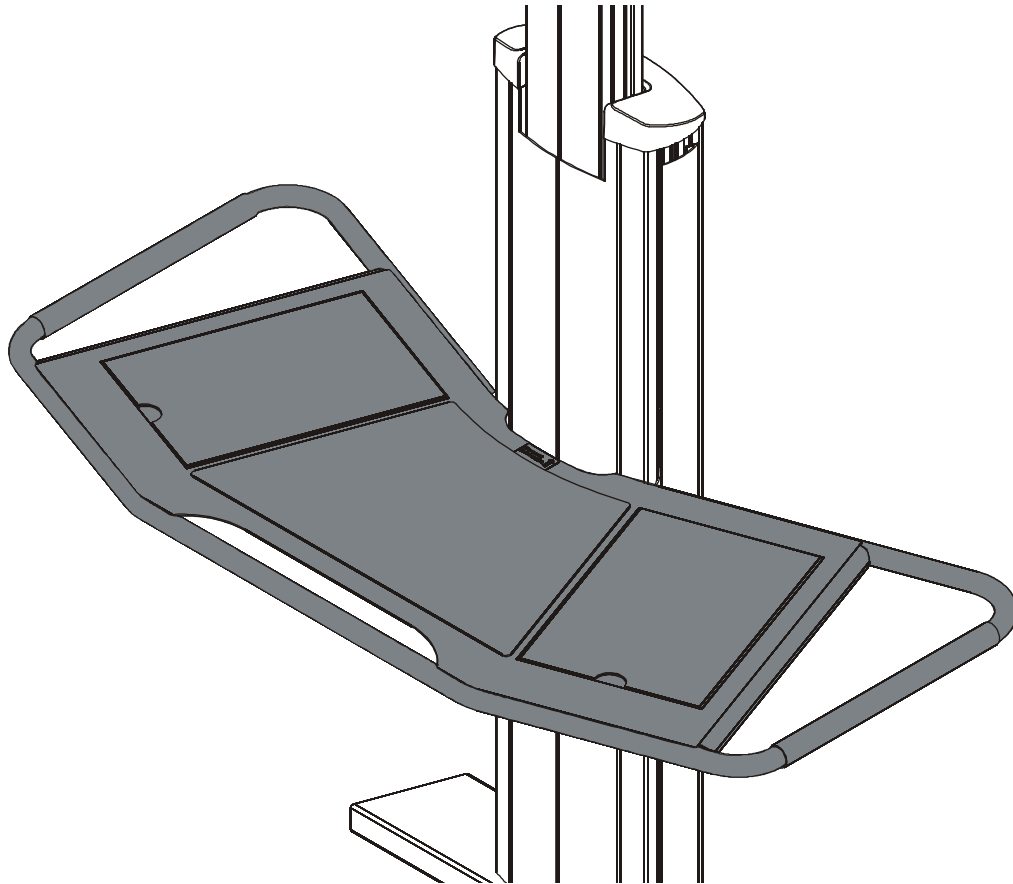

Large Shelf for Fusion™ Cart

DISCLAIMER

Milestone AV Technologies and its affiliated corporations and subsidiaries (collectively "Milestone"), intend to make this manual accurate and complete. However, Milestone makes no claim that the information contained herein covers all details, conditions or variations, nor does it provide for every possible contingency in connection with the installation or use of this product. The information contained in this document is subject to change without notice or obligation of any kind. Milestone makes no representation of warranty, expressed or implied, regarding the information contained herein. Milestone assumes no responsibility for accuracy, completeness or sufficiency of the information contained in this document.

Chief® is a registered trademark of Milestone AV Technologies. All rights reserved.

IMPORTANT SAFETY INSTRUCTIONS

 **WARNING:** A WARNING alerts you to the possibility of serious injury or death if you do not follow the instructions.

 **CAUTION:** A CAUTION alerts you to the possibility of damage or destruction of equipment if you do not follow the corresponding instructions.

 **WARNING:** Failure to read, thoroughly understand, and follow all instructions can result in serious personal injury, damage to equipment, or voiding of factory warranty! It is the installer's responsibility to make sure all components are properly assembled and installed using the instructions provided.

 **WARNING:** Failure to provide adequate structural strength for this component can result in serious personal injury or damage to equipment! It is the installer's responsibility to make sure the structure to which this component is attached can support five times the combined weight of all equipment. Reinforce the structure as required before installing the component.

 **WARNING:** Exceeding the weight capacity can result in serious personal injury or damage to equipment! It is the installer's responsibility to make sure the combined weight of all components located on the FCA610 does not exceed 25 lbs (11.34 kg).

 **WARNING:** Use this mounting system only for its intended use as described in these instructions. Do not use attachments not recommended by the manufacturer.

 **WARNING:** Never operate this mounting system if it is damaged. Return the mounting system to a service center for examination and repair.

 **WARNING:** Do not use this product outdoors.







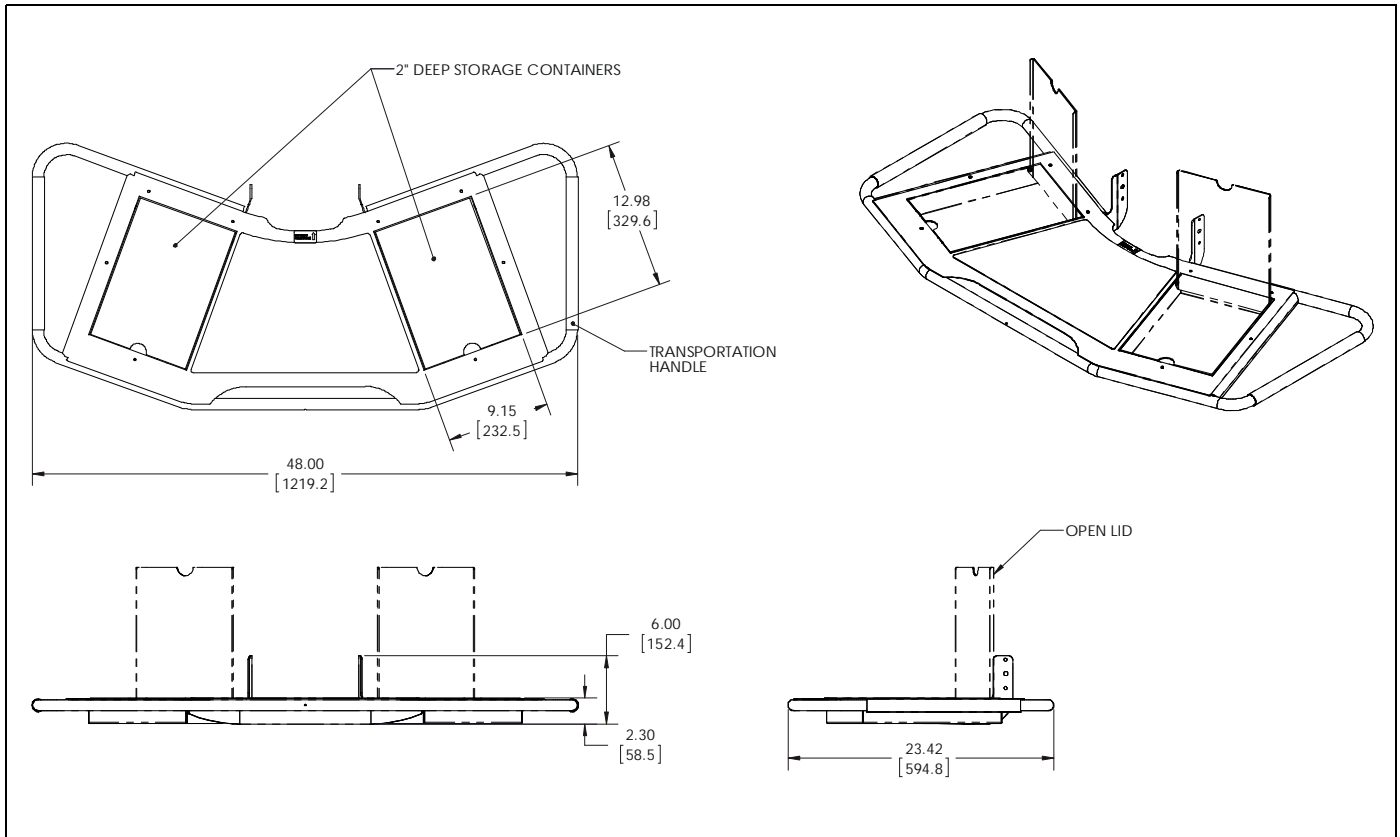

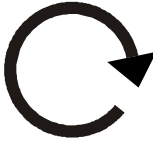

 **WARNING:** RISK OF INJURY TO PERSONS! Do not place video equipment such as televisions or computer monitors on cart legs.

--SAVE THESE INSTRUCTIONS--

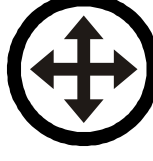
DIMENSIONS



LEGEND

	Tighten Fastener Apretar elemento de fijación Befestigungsteil festziehen Apertar fixador Serrare il fissaggio Bevestiging vastdraaien Serrez les fixations		Pencil Mark Marcar con lápiz Stiftmarkierung Marcar com lápis Segno a matita Potloodmerkteken Marquage au crayon
	Loosen Fastener Aflojar elemento de fijación Befestigungsteil lösen Desapertar fixador Allentare il fissaggio Bevestiging losdraaien Desserrez les fixations		Drill Hole Perforar Bohrloch Fazer furo Praticare un foro Gat boren Percez un trou
	Phillips Screwdriver Destornillador Phillips Kreuzschlitzschraubendreher Chave de fendas Phillips Cacciavite a stella Kruiskopschroevendraaier Tournevis à pointe cruciforme		Adjust Ajustar Einstellen Ajustar Regolare Afstellen Ajuster
	Open-Ended Wrench Llave de boca Gabelschlüssel Chave de bocas Chiave a punte aperte Steeksleutel Clé à fourche		Remove Quitar Entfernen Remover Rimuovere Verwijderen Retirez
	By Hand A mano Von Hand Com a mão A mano Met de hand À la main		Optional Opcional Optional Opcional Opzionale Optie En option
	Hex-Head Wrench Llave de cabeza hexagonal Sechskantschlüssel Chave de cabeça sextavada Chiave esagonale Zeskantsleutel Clé à tête hexagonale		Security Wrench Llave de seguridad Sicherheitsschlüssel Chave de segurança Chiave di sicurezza Veiligheidsleutel Clé de sécurité

TOOLS REQUIRED FOR INSTALLATION

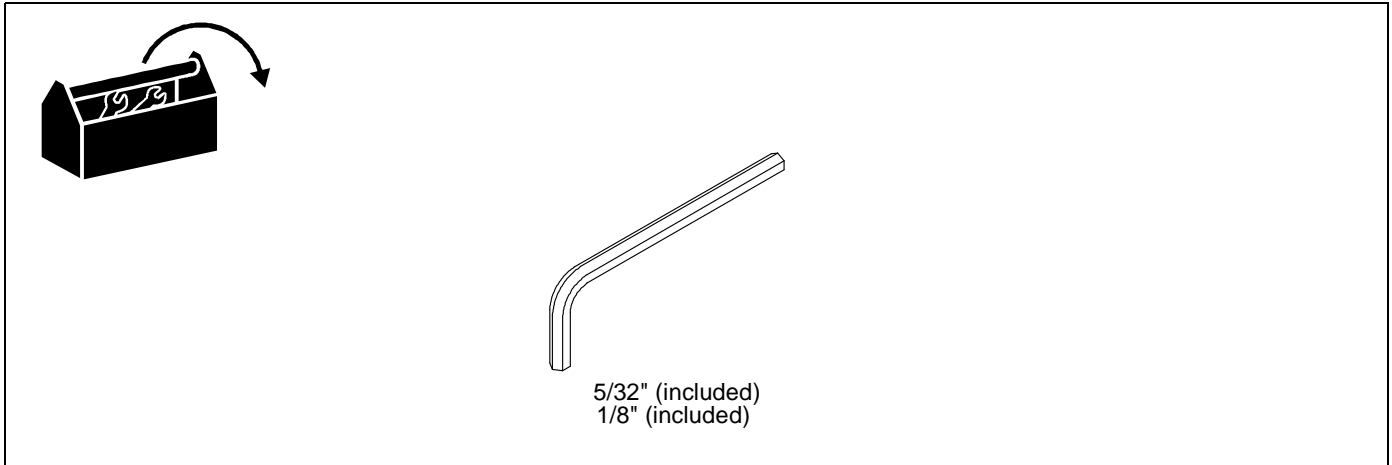

PARTS

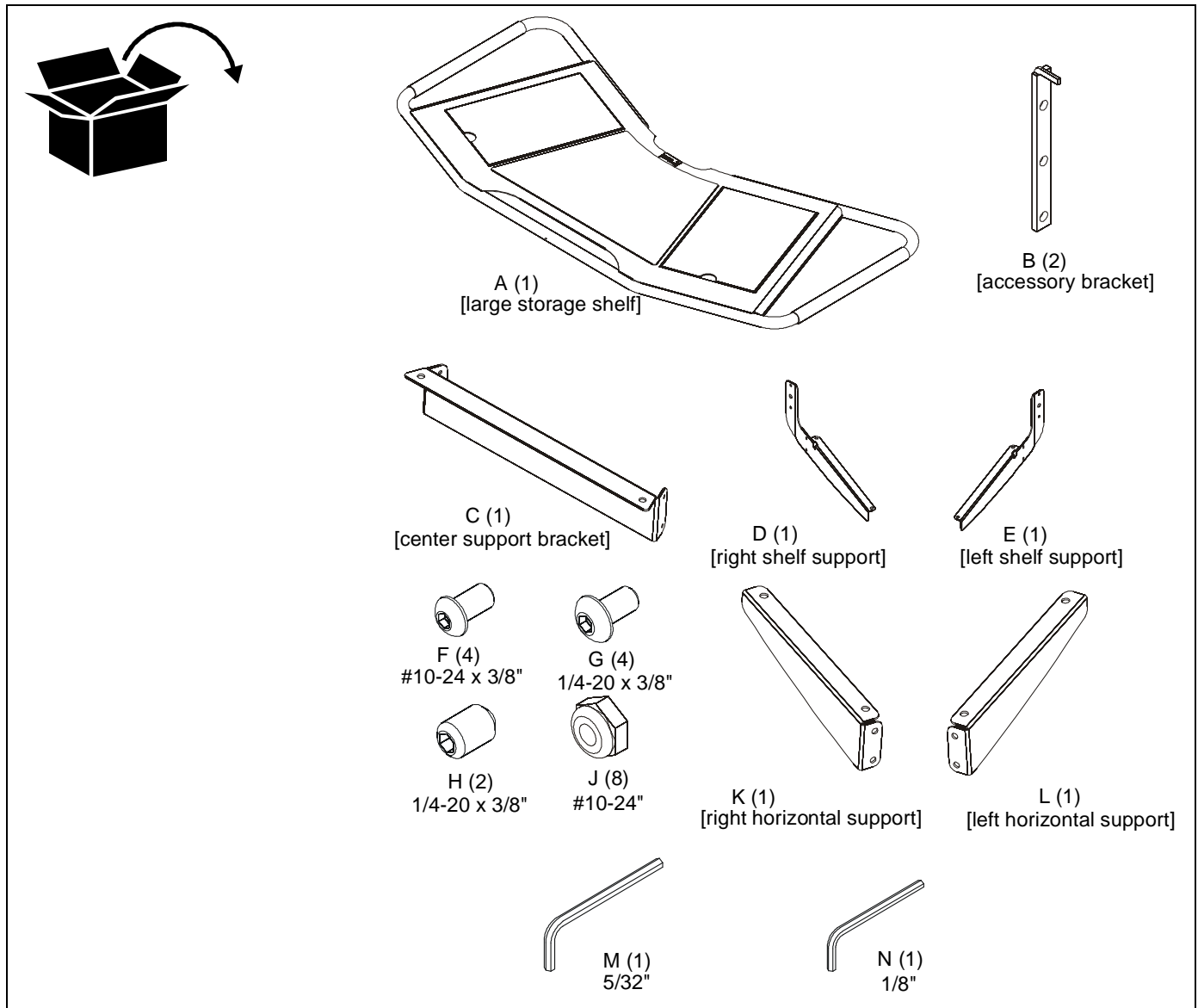

Assembly And Installation

NOTE: The following procedure assumes the Fusion™ Cart/ Stand has already been completely assembled with the display attached.

IMPORTANT ! : The FCA610 shelf has been designed specifically for Chief's Fusion™ Series Carts and Stands. DO NOT attempt to install this shelf onto any other cart or stand!

1. Remove back cover from cart/stand. (See Figure 1)
2. Remove column inner cover from cart/stand. (See Figure 1)
3. Remove side covers from cart/stand by sliding them up the channel. (See Figure 1)

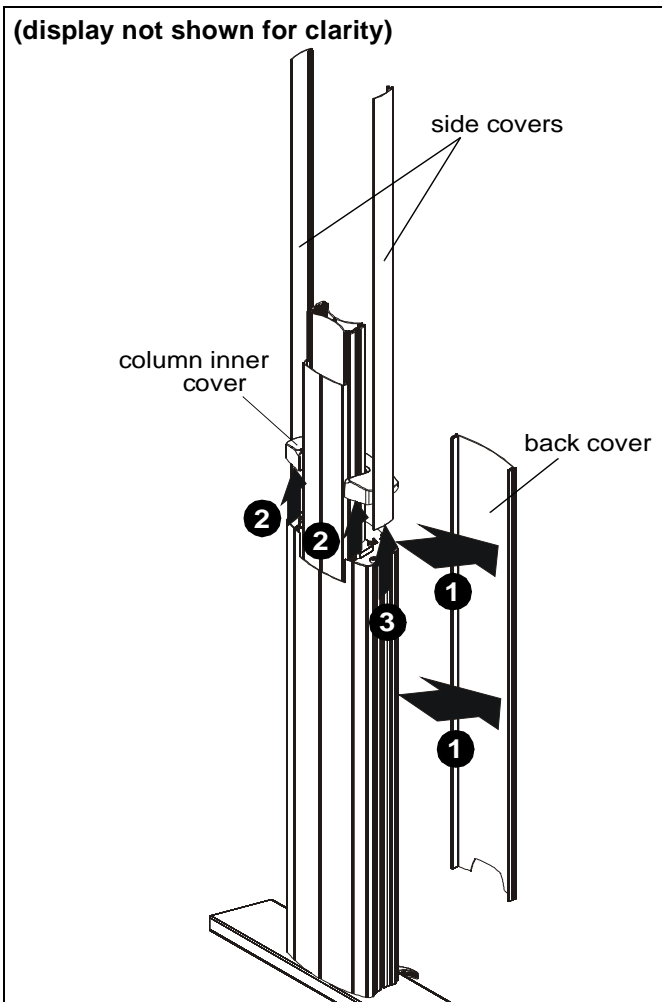

Figure 1

4. Partially install 1/4-20 x 3/8" set screw (H) into accessory bracket (B). (See Figure 2)
5. Slide accessory bracket (B) with set screw (H) into side channel. (See Figure 2)

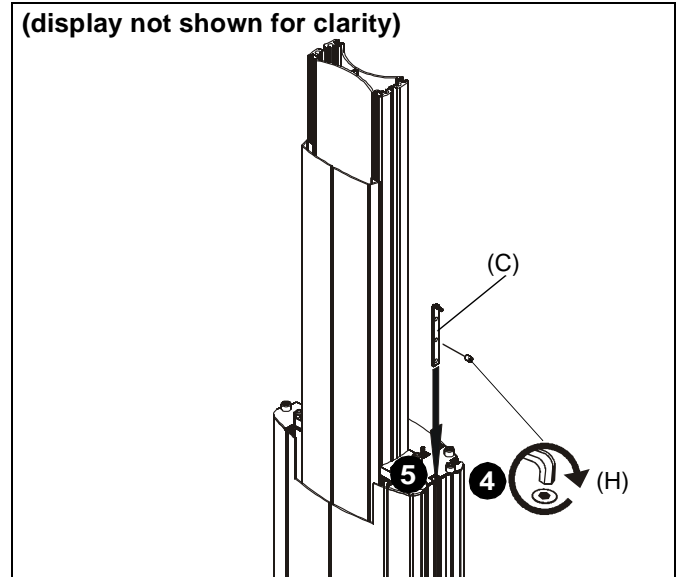

Figure 2

6. Slide accessory bracket (B) up or down in side channel until desired mounting height is reached. (See Figure 3)
7. Tighten set screw (H) to lock bracket in position. (See Figure 3)
8. Repeat Steps 4-7 on other side, making sure bracket position lines up horizontally with the other bracket.
9. Use four 1/4-20 x 3/8" button head cap screws (G) to secure right and left shelf supports (D and E) to adapter bracket (C). (See Figure 3)
10. Use four #10-24 x 3/8" button head cap screws (F) to secure right and left horizontal supports (K and L) to right and left shelf supports (D and E) and center support bracket (C). (See Figure 3)

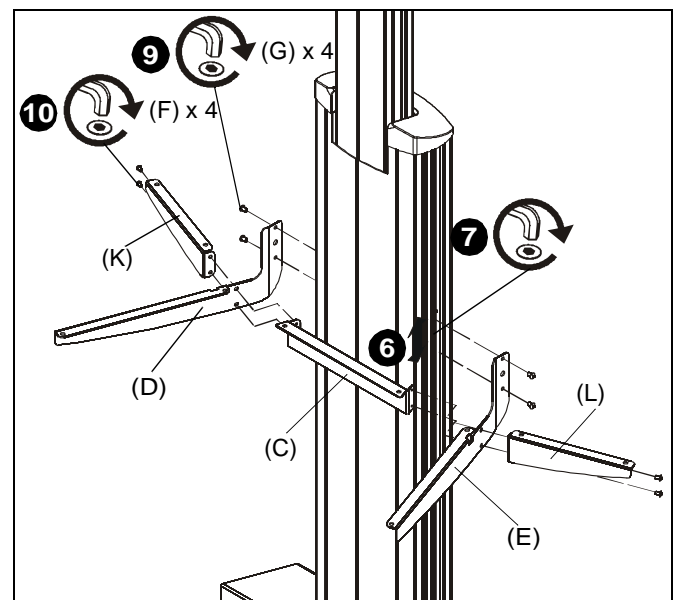

Figure 3

11. Place large shelf (A) onto support brackets (C, D, E, K and L) making sure corresponding screws on underside of shelf line up with mounting holes on brackets. (See Figure 4) and (See Figure 5)
12. Use four #10-24" lock nuts (J) to secure right and left shelf supports (D and E) to large shelf (A). (See Figure 4) and (See Figure 5)
13. Use four #10-24" lock nuts (J) to secure right and left horizontal supports (L and M) to large shelf (A). (See Figure 4) and (See Figure 5)

14. Reinstall side covers into side slots on cart/stand column. (See Figure 6)
15. Reinstall column inner cover to cart/stand column. (See Figure 6)
16. Reinstall back cover to cart/stand column. (See Figure 6)
17. Install components to shelf and shelf drawers. (See Figure 6)



WARNING: Exceeding the weight capacity can result in serious personal injury or damage to equipment! It is the installer's responsibility to make sure the combined weight of all components located on the FCA610 does not exceed 25 lbs (11.34 kg).

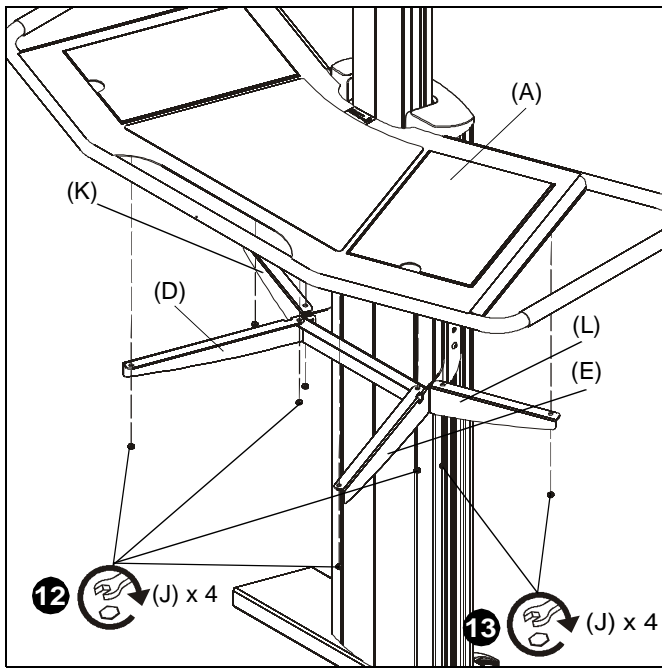

Figure 4

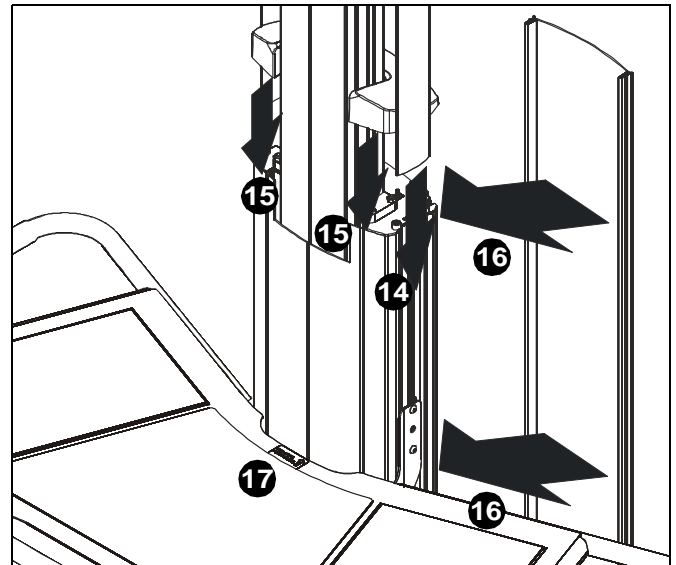

Figure 6

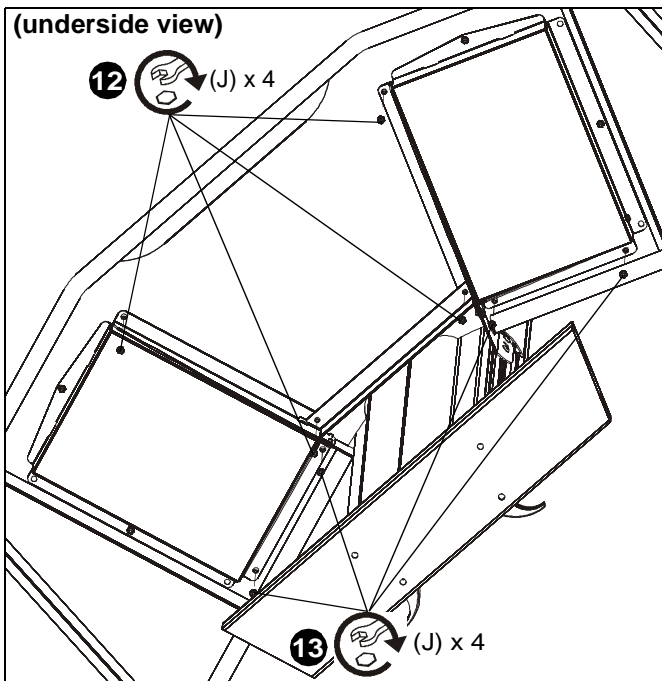

Figure 5

Adjustments

Height Adjustment

1. Remove column inner cover from cart/stand. (See Figure 7)
2. Remove side covers from cart/stand by sliding them up the channel. (See Figure 7)
3. Loosen set screws on each side of shelf. (See Figure 8)
4. Loosen all button head cap screws holding shelf to column. (See Figure 8)
5. Adjust shelf height to desired level. (See Figure 8)
6. Tighten all button head cap screws holding shelf to column. (See Figure 8)
7. Reinstall side covers into side slots on cart/stand column. (See Figure 8)
8. Reinstall column inner cover to cart/stand column. (See Figure 8)

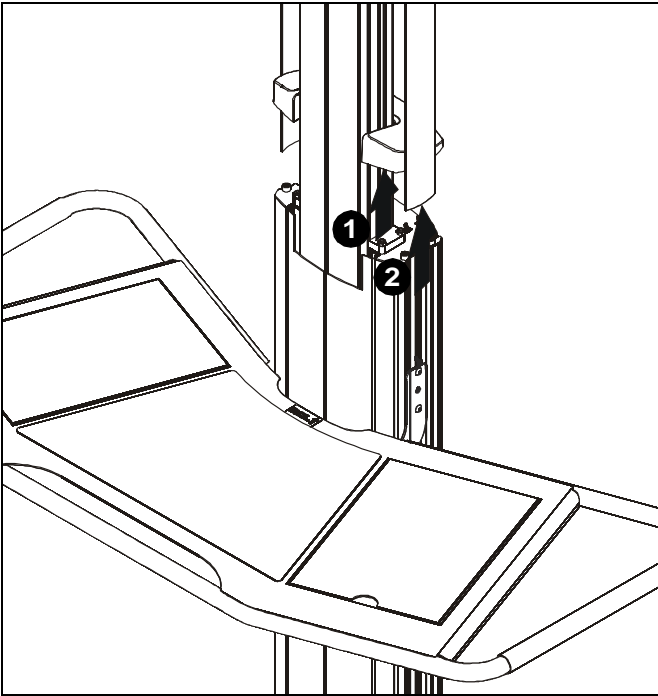

Figure 7

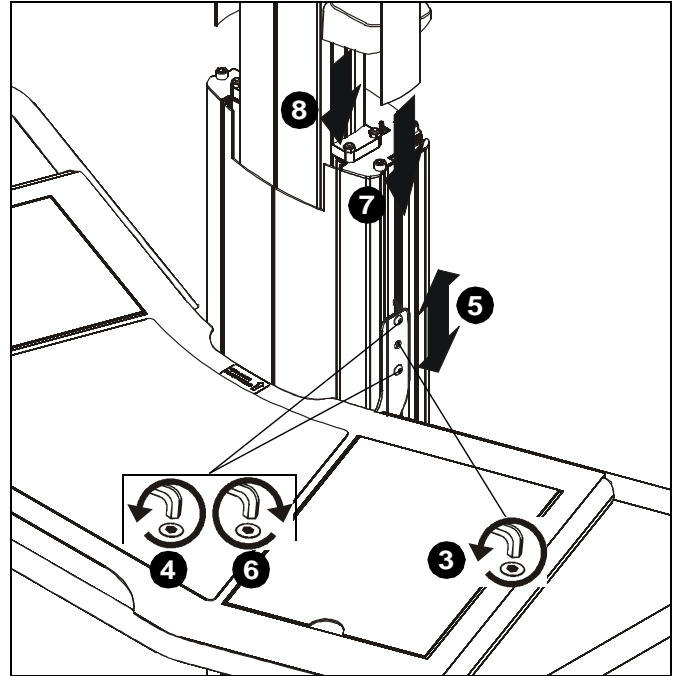

Figure 8



Our Mounts. **Your Vision.**

Chief Manufacturing, a products division
of Milestone AV Technologies

8800-002261 Rev01
©2012 Milestone AV Technologies, a
Duchossois Group Company
www.chiefmfg.com
11/12

USA/International	A 6436 City West Parkway, Eden Prairie, MN 55344 P 800.582.6480 / 952.225.6000 F 877.894.6918 / 952.894.6918
Europe	A Franklinstraat 14, 6003 DK Weert, Netherlands P +31 (0) 495 580 852 F +31 (0) 495 580 845
Asia Pacific	A Office No. 1 on 12/F, Shatin Galleria 18-24 Shan Mei Street Fotan, Shatin, Hong Kong P 852 2145 4099 F 852 2145 4477

