

---

# INSTALLATION INSTRUCTIONS

---

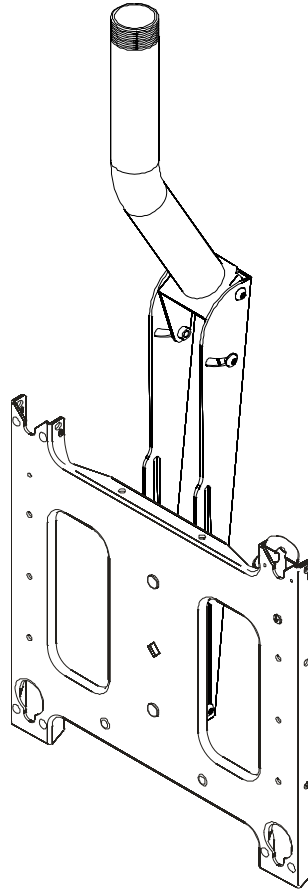

---

**Plasma Ceiling Mount**

---

## DISCLAIMER

Milestone AV Technologies, Inc., and its affiliated corporations and subsidiaries (collectively, "Milestone"), intend to make this manual accurate and complete. However, Milestone makes no claim that the information contained herein covers all details, conditions or variations, nor does it provide for every possible contingency in connection with the installation or use of this product. The information contained in this document is subject to change without notice or obligation of any kind. Milestone makes no representation of warranty, expressed or implied, regarding the information contained herein. Milestone assumes no responsibility for accuracy, completeness or sufficiency of the information contained in this document.

## IMPORTANT WARNINGS AND CAUTIONS!

**WARNING:** A WARNING alerts you to the possibility of serious injury or death if you do not follow the instructions.

**CAUTION:** A CAUTION alerts you to the possibility of damage or destruction of equipment if you do not follow the corresponding instructions.

**WARNING:** Failure to read, thoroughly understand, and follow all instructions can result in serious personal injury, damage to equipment, or voiding of factory warranty! It is the installer's responsibility to make sure all components are properly assembled and installed using the instructions provided.

**WARNING:** Failure to provide adequate structural strength for the installation of this kit can result in serious personal injury or damage to equipment! It is the installer's responsibility to make sure the structure to which this mount is attached can support five times the combined weight of all equipment.

**WARNING:** Exceeding the weight capacity can result in serious personal injury or damage to equipment! It is the installer's responsibility to make sure the combined weight of all components attached to this mount does not exceed 200 lbs (91 kg).

**WARNING:** The installer is responsible for verifying that the 1 1/2" NPT fixture this mount is installed on is capable of supporting four times the maximum weight capacity of the mount as stated above.

## LEGEND

	Tighten Fastener
	Apretar elemento de fijación
	Befestigungsteil festziehen
	Apertar fixador
	Serrare il fissaggio
	Bevestiging vastdraaien
	Serrez les fixations
	Сожмите Застежку

	Loosen Fastener
	Afajar elemento de fijación
	Befestigungsteil lösen
	Desapertar fixador
	Allentare il fissaggio
	Bevestiging losdraaien
	Desserrez les fixations
	Ослабьте Застежку

	Open-Ended Wrench
	Llave de boca
	Gabelschlüssel
	Chave de bocas
	Chiave a punta aperte
	Steeksleutel
	Clé à fourche
	Открытый Рывок

	Adjust
	Ajustar
	Einstellen
	Ajustar
	Regolare
	Afstellen
	Ajuster
	Приспособьтесь

	Hex-Head Wrench
	Llave de cabeza hexagonal
	Sechskantschlüssel
	Chave de cabeça sextavada
	Chiave esagonale
	Zeskantsleutel
	Clé à tête hexagonale
	Главный вейдмой Рывок

	Phillips Screwdriver
	Destornillador Phillips
	Kreuzschlitzschraubendreher
	Chave de fendas Phillips
	Cacciavite a stella
	Kruiskopschroevendraaier
	Tournevis à pointe cruciforme
	Отвертка

**TOOLS REQUIRED FOR INSTALLATION AND PARTS**

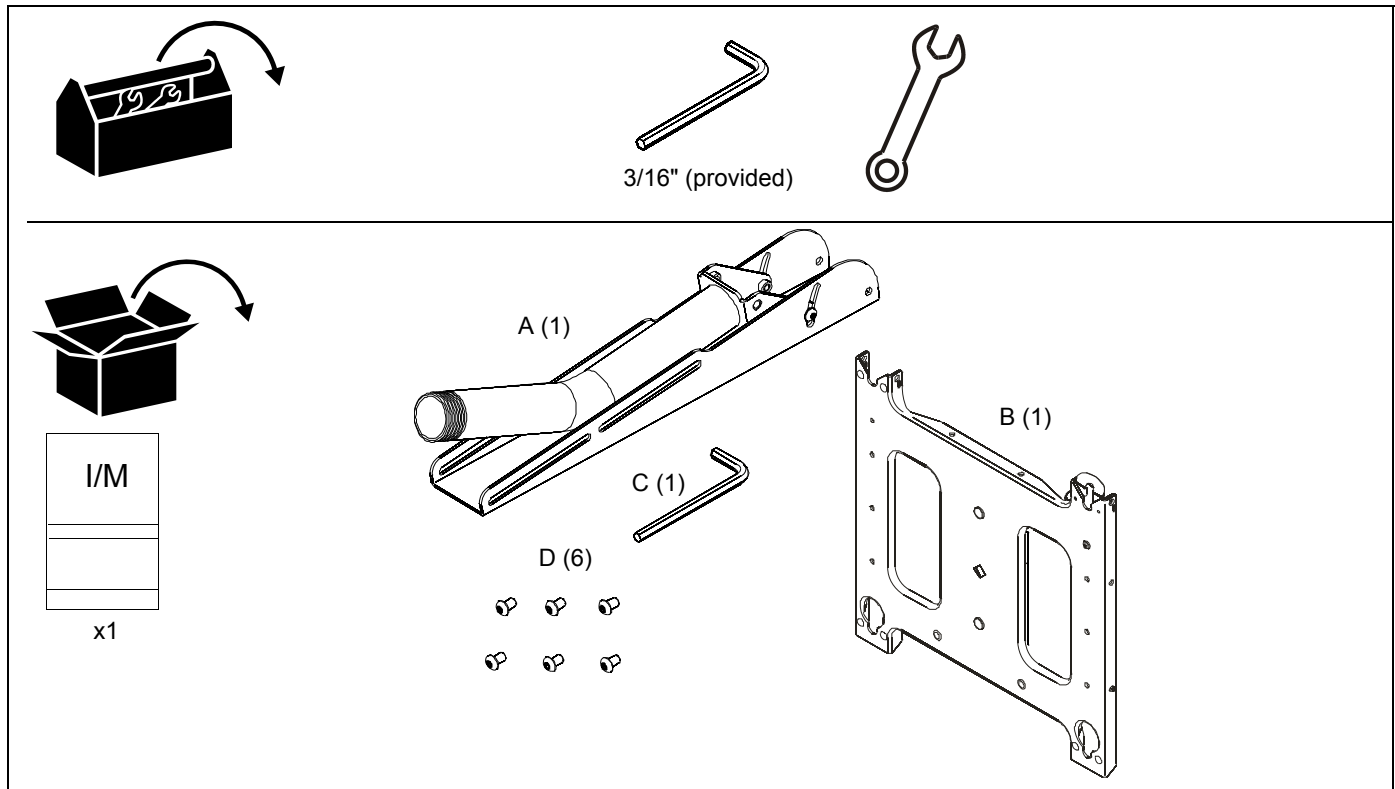

**DIMENSIONS**

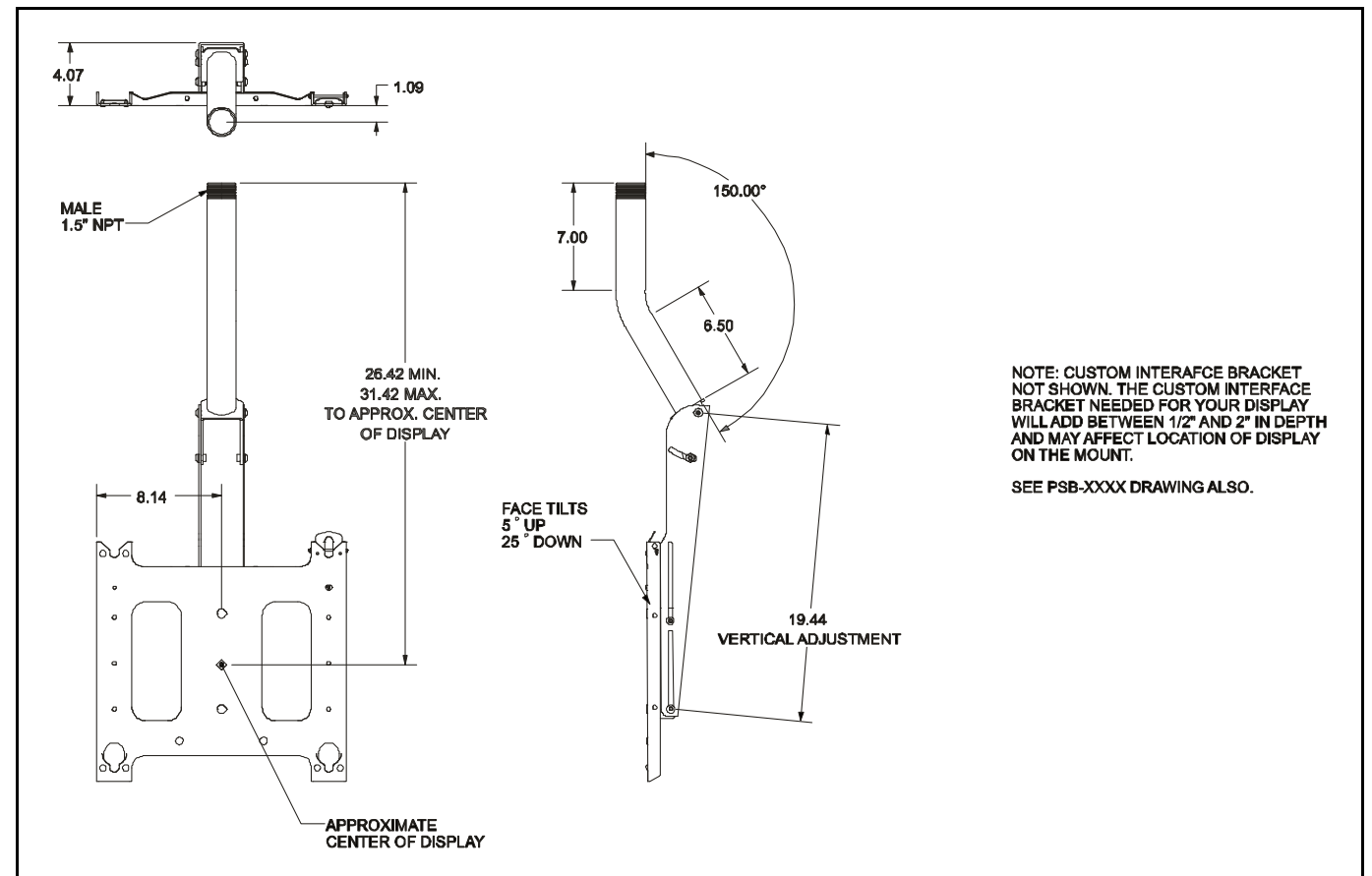

Figure 1

### Mount Assembly and Installation

1. Fold tube out until tube mounting bracket rests against faceplate mounting bracket. (See Figure 2)
2. Secure tube to faceplate mounting bracket using 3/16" hex wrench (C) and two 5/16-18 x 1/2" button head cap screws (D).
3. Tighten all hardware.

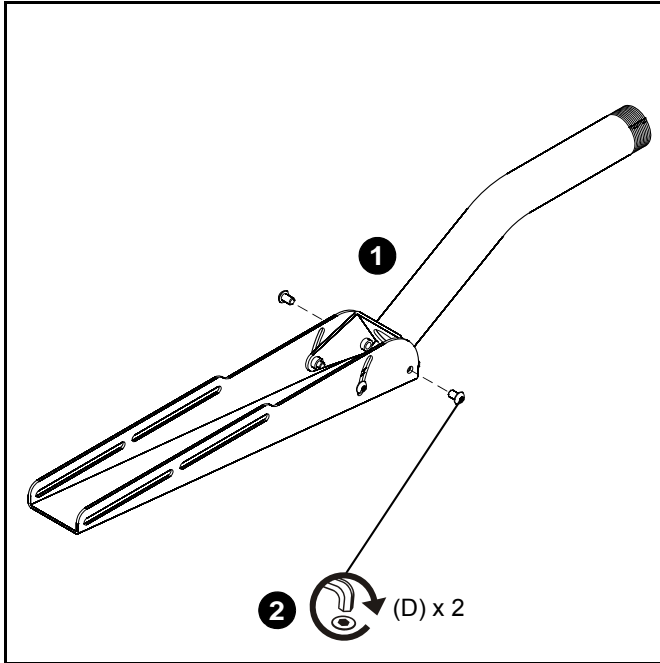

Figure 2

4. Thread the tube assembly (A) onto 1-1/2" NPT.
- NOTE:** The product is suitable for use with a Listed ceiling plate which can accommodate 1-1/2" NPT pipe, and has a rated weight capacity of 200 lbs (91 kg).
5. Secure faceplate (B) to faceplate mounting bracket using 3/16" hex wrench (C) and four 5/16-18 x 1/2" button head cap screws (D).

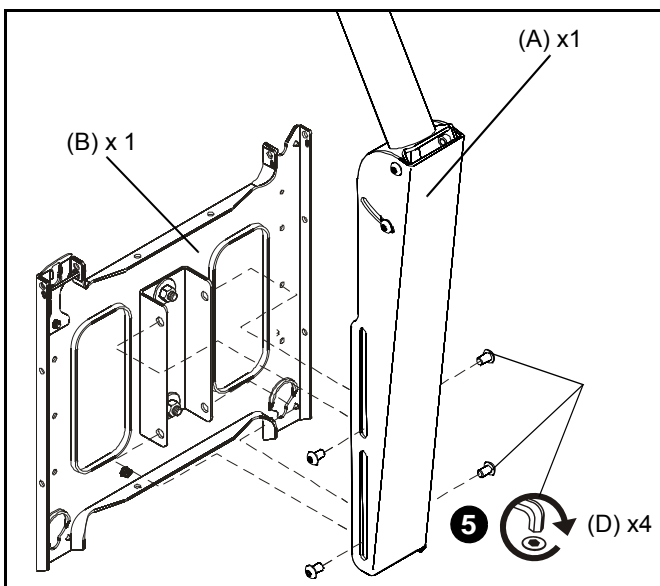

Figure 3

### Display Installation

If the mounting pattern of the display being installed is a VESA standard 200 x 200 pattern the mounting buttons can be installed directly to the back of the display. If the display has any other mounting pattern an interface bracket must be obtained before proceeding. Consult a Chief Customer Service representative if an interface bracket is required by calling 1-800-582-6480 or visit [www.chiefmfg.com](http://www.chiefmfg.com).



**WARNING:** IMPROPER INSTALLATION CAN LEAD TO MOUNT FALLING CAUSING SEVERE PERSONAL INJURY OR DAMAGE TO EQUIPMENT. Displays can weigh in excess of 40 lbs (18.1kg). ALWAYS use two people and proper lifting techniques when installing display.



**WARNING:** IMPROPER INSTALLATION CAN LEAD TO MOUNT FALLING CAUSING SEVERE PERSONAL INJURY OR DAMAGE TO EQUIPMENT. Make sure mounting buttons on display are properly seated in mounting holes in faceplate.

To install display:

1. While supporting both sides of display, align four mounting buttons on display or interface bracket with four mounting holes in faceplate. (See Figure 4)
2. Lower display into place listening for audible "click" to ensure recessed area of mounting buttons are properly seated in lower area of mounting holes and "click lock" mechanism has engaged. (See Figure 4) and (See Figure 5)

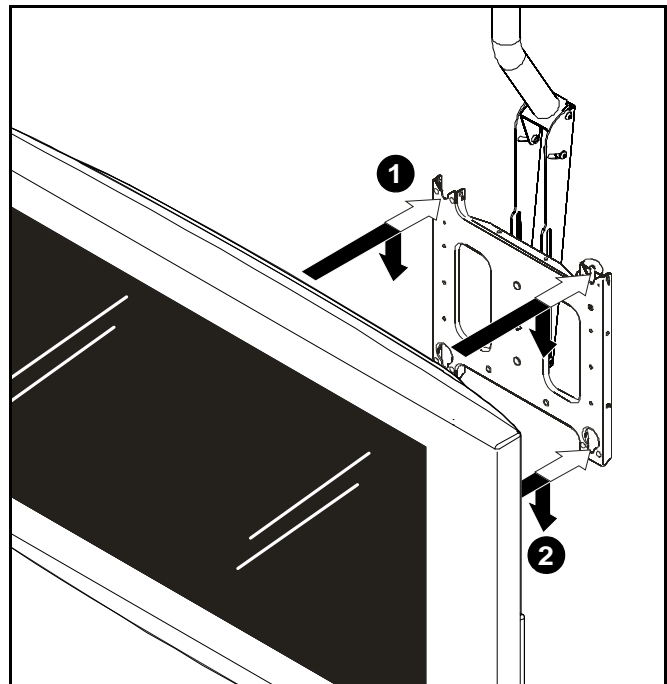

Figure 4

**NOTE:** Holes are provided in the faceplate for use with a padlock or similar locking device, if desired. In addition, the pin and nut may be removed from the upper holes and moved to the lower holes for use as a more permanent locking device. (See Figure 5)

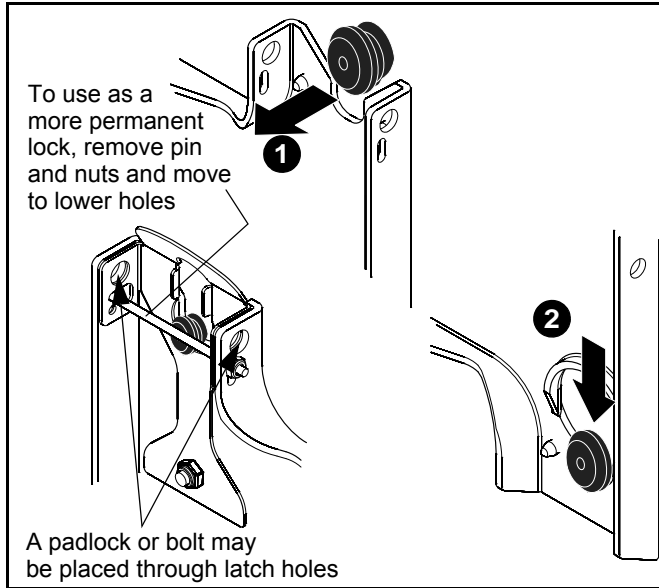

Figure 5

### Adjustments

The PCM is designed to accommodate 5" of display height adjustment, 4° right and left display roll adjustment, and 15° down/5° up display pitch (Tilt) adjustment.

Remove display before performing adjustments.

#### Display Height Adjustment

To adjust display height:

1. Loosen four 5/16-18 button head cap screws using 3/16" hex wrench (C). (See Figure 6)
2. Adjust faceplate to desired position. (See Figure 6)
3. Tighten four 5/16-18 button head cap screws using 3/16" hex wrench (C). (See Figure 6)

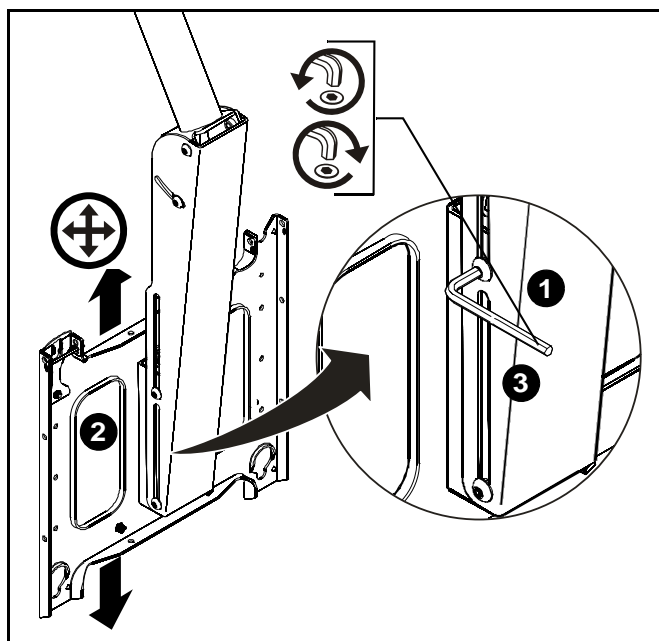

Figure 6

#### Display Roll Adjustment

To adjust display roll:

1. Loosen 3/8-16 Nylock nut. (See Figure 7)
2. Adjust faceplate to desired position. (See Figure 7)
3. Tighten 3/8-16 Nylock nut. (See Figure 7)

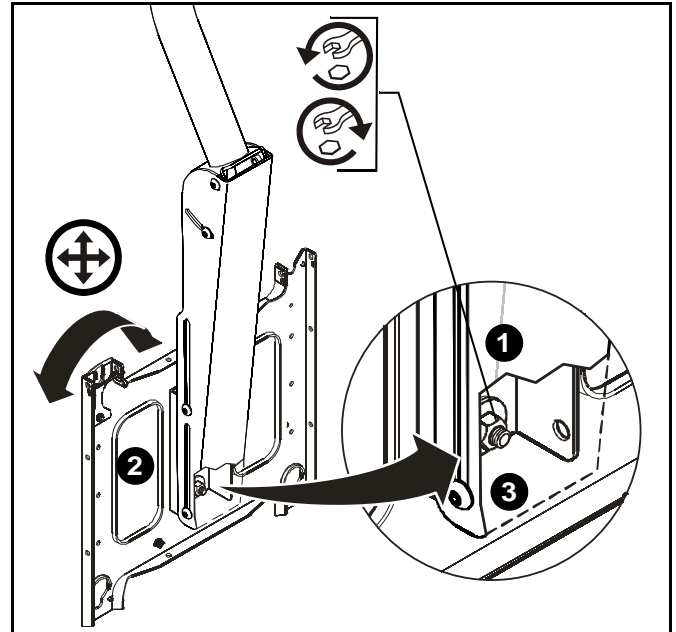

Figure 7

#### Display Pitch (Tilt) Adjustment

To adjust display pitch:

1. Loosen four 5/16-18 button head cap screws. (See Figure 8)
2. Adjust to desired tilt position. (See Figure 8)
3. Tighten four 5/16-18 button head cap screws. (See Figure 8)

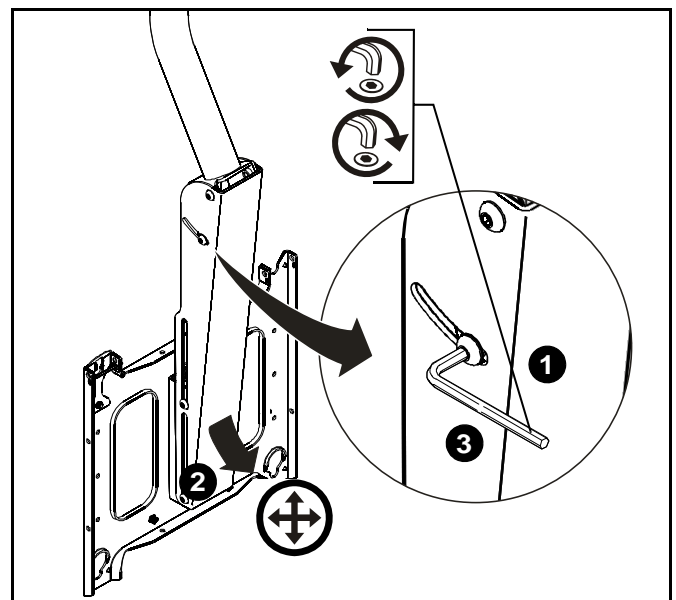

Figure 8





Chief® and ClickConnect™ are trademarks of Milestone AV Technologies, Inc. All rights reserved.



Chief Manufacturing, a division of  
Milestone AV Technologies

8805-000114 RevE  
©2008 Milestone AV Technologies  
[www.chiefmfg.com](http://www.chiefmfg.com)  
04/08

<b>USA/International</b>	<b>A</b> 8401 Eagle Creek Parkway, Savage, MN 55378 <b>P</b> 800.582.6480 / 952.894.6280 <b>F</b> 877.894.6918 / 952.894.6918
<b>Europe</b>	<b>A</b> Fellenoord 130 5611 ZB EINDHOVEN, The Netherlands <b>P</b> +31 (0)40 2668620 <b>F</b> +31 (0)40 2668615
<b>Asia Pacific</b>	<b>A</b> Room 24F, Block D, Lily YinDu International Building LuoGang, BuJi Town, Shenzhen, CHINA. <b>深圳市布吉罗岗村百合银都国际大厦D栋24F</b> <b>P</b> +86-755-8996 9226 <b>F</b> +86-755-8996 9217

