

M8 Installation Instructions

CABLE MANAGEMENT

- a. The M8 includes a cable management system to keep monitor cables organized and protected. Start by inserting cables into Cable Clip A.
- b. Route cables across the bottom of the Upper Arm and around to the top of the Lower Arm. Insert cables into groove on top of the Lower Arm (B). Place Arm Cover (C) onto the Lower Arm so that the grooves interlock. Slide Arm Cover up until it snaps in place.

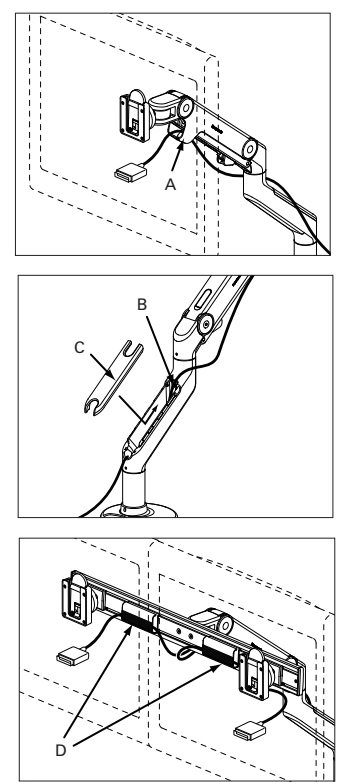

Note: For dual-monitor applications, first route monitor cables through cable management clips (D), then refer to Step a.

M8 INSTALLATION HARDWARE

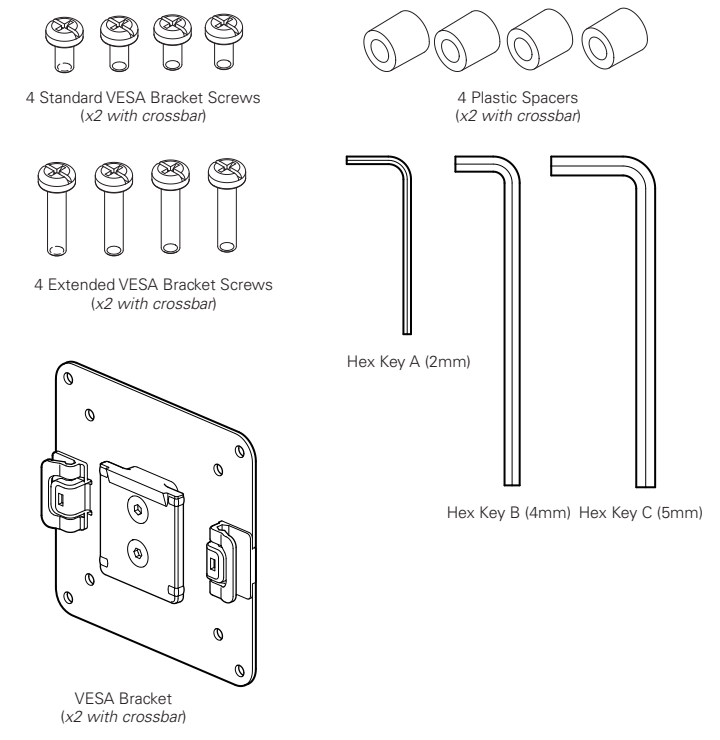

FRICTION ADJUSTMENT

- a. If your monitor is particularly heavy, or after prolonged use, the Ball Joint Swivel/Tilt Mechanism may require increased friction. This can be achieved by tightening the 3 Ball Joint Friction Screws (A) using Hex Key B.

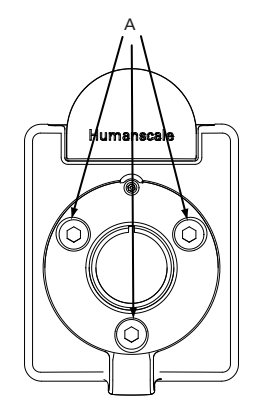

Bolt-Through Mount

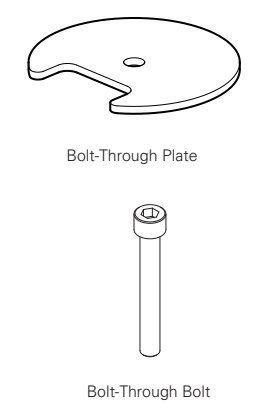

Clamp Mount

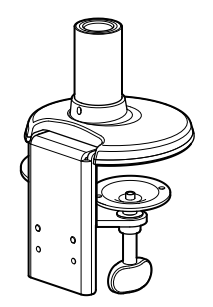

HEX KEY STORAGE

- a. The M8's VESA bracket is built to house 2 Hex Keys for storage. Insert Hex Key B and Hex Key C into the clips on either side of the VESA bracket, making sure each Hex Key corresponds to the size of the lip.

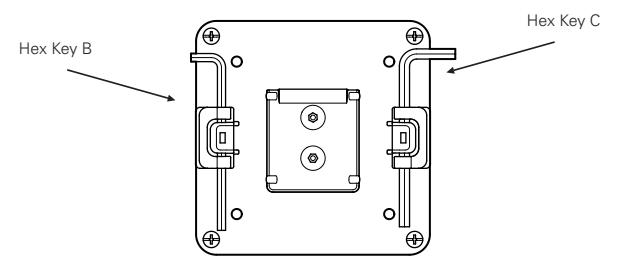

CROSSBAR INSTALLATION HARDWARE



STEP 1: ATTACH MOUNT TO WORK SURFACE

CLAMP MOUNT

- a. For installation on open edge of work surface:

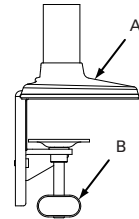

- i. Slide Mount (A) against work surface edge and fully tighten Clamp Screws (B).

Note: If work surface is too thin to attach Mount at default setting, proceed to Step b.

- ii. Proceed to Step 2.

- b. For installation on work surface positioned against a wall or panel:

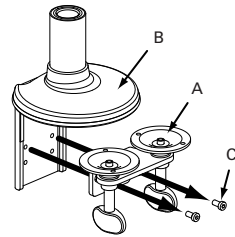

- i. Attach arm to Base Stem following Step 2 instructions before proceeding.

- ii. Detach the Bottom Clamp (A) from the Top Bracket (B) by loosening Bracket Screws (C) with Hex Key B.

- iii. Position the Top Bracket against work surface edge.

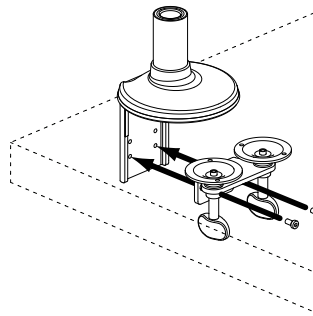

- iv. Underneath the work surface, reattach the Bottom Clamp to the Top Bracket using the Bracket Screws.

Note: There are two sets of Bracket Screw holes to accommodate different surface thicknesses. Use the set of holes that allow the Clamp Screws to tighten fully. Use the top holes for surfaces up to 1.8" (48mm) thick and lower holes for surfaces up to 2.7" (68mm) thick.

- v. Fully tighten Clamp Screws.

- vi. Proceed to Step 2.

BOLT-THROUGH MOUNT

- a. If both mount options were purchased, begin with Step i below. Otherwise, proceed to Step iii.

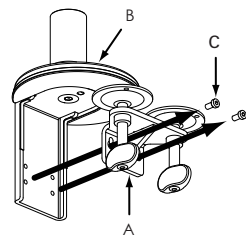

- i. To convert from Clamp Mount to Bolt-Through Mount, detach Bottom Clamp (A) from Top Bracket (B) by loosening Bracket Screws (C) with Hex Key B.

- ii. Using an 8mm Hex Key (not included), remove Base Stem Screw (D) from Mount.

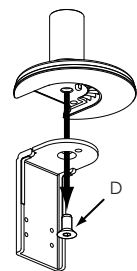

- iii. Drill 1/2" (13mm) hole through work surface in desired location.

Note: Bolt-Through Mount can accommodate a hole up to 4" (102mm) in diameter. If hole is 2" (51mm) or more, cables can be routed through the hole. For some 2" grommet holes, cables should be routed before installation of mount to accommodate cable plugs (cable access is approximately 1.5" x 0.25" with 2" grommets).

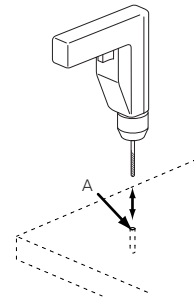

- iv. Position the M8 Base over the work surface hole (A).

- v. Align Bolt-Through Plate (A) under the work surface. Pass the Bolt-Through Bolt (B) through the hole in the plate (C) and screw into M8 Base. Using a 10mm Hex Key (not included), fully tighten until secure.

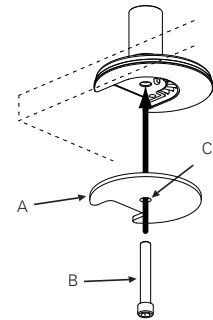

- vi. Proceed to Step 2.

STEP 2: ATTACH ARM TO BASE STEM

- a. Insert M8 Arm (A) into the Base Stem (B).
- b. Using Hex Key A, tighten Screw (C) so that the arm is unable to lift out.

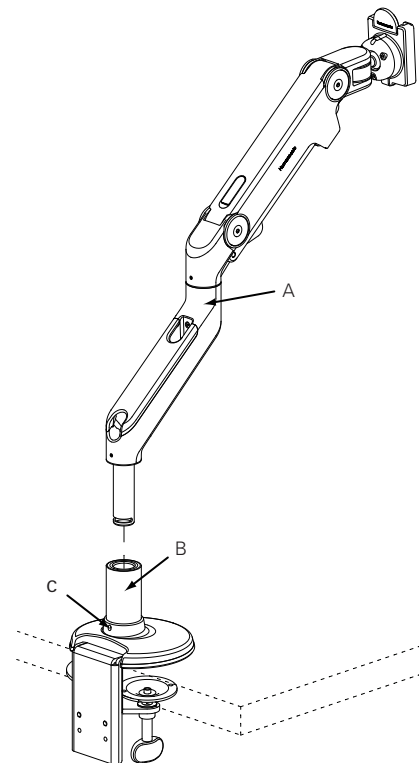

STEP 3: ATTACH VESA BRACKET TO MONITOR

- a. Place VESA Bracket in position on back of monitor with clips (A) on the left and right. Attach using 4 Standard VESA Bracket Screws provided. VESA bracket can accommodate 75mm and 100mm hole patterns. For this installation, you may also use screws that came with your monitor.

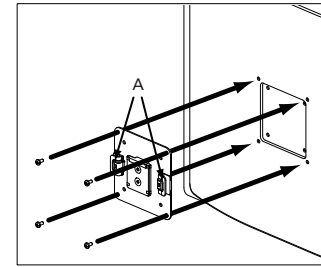

- i. If mounting space for 75mm VESA bracket is inset into back of monitor, place the 4 Plastic Spacers (B) between VESA Bracket and monitor (align with hole pattern), and using the 4 Extended VESA Bracket Screws (C), attach through the Spacers.

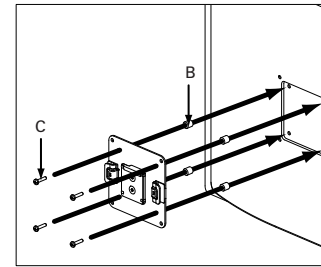

STEP 4: ATTACH CROSSBAR TO ARM (DUAL-MONITOR APPLICATION ONLY)

- a. If using Crossbar for dual-monitor application, follow Step i below. Otherwise, proceed to Step 5.
- i. Attach Crossbar (A) to Crossbar Link (B) using Crossbar Link Screws (C). Tighten with Hex Key D until secure.

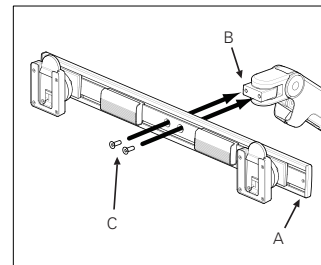

STEP 5: ATTACH MONITOR TO ARM

- a. Slide VESA Bracket (A) into Ball Joint until it clicks.
- b. To remove, depress Quick-Release Tab (B) and slide monitor up and away from Arm.
- c. If security is required, tighten Security Screw using Hex Key A.

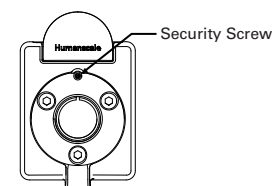
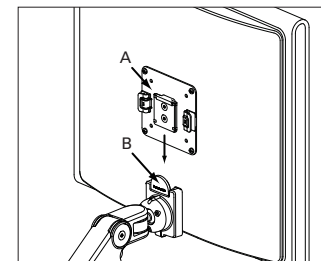

STEP 6: MONITOR WEIGHT ADJUSTMENT

- a. Your monitor should move up and down easily and stay in place once adjusted. If it is difficult to adjust or moves without assistance, it is not properly counterbalanced.

Use Hex Key C to adjust the Tension Screw (A) located in the Upper Arm of the M8. Turn the Tension Screw clockwise to increase tension for larger, heavier monitors. Turn the Tension Screw counterclockwise to decrease tension for smaller, lighter monitors.

Note: Monitor should not exceed 40 lbs (18 kg).

- i. If further tension adjustment is required, tension can be fine tuned via the half-dollar-size friction discs (B) located on the side of the M8's Upper Arm.

Use Hex Key B to turn the screws on each friction disc clockwise to increase friction. Turn each screw counterclockwise to decrease friction. Be sure to apply the same amount of rotation to each screw.

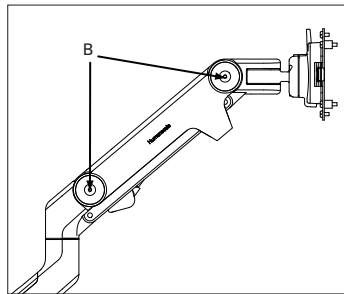
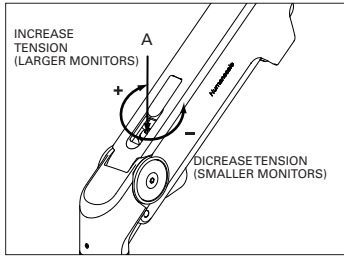

MONITOR HEIGHT ADJUSTMENT (DUAL-MONITOR APPLICATION ONLY)

- a. To fine tune the height of your monitor when using the Crossbar for dual-monitor applications, use Hex Key B to turn Screw (A). This will adjust your monitor's height up or down.

