

# WPSMS Assembly Instructions



## H. WILSON

H. Wilson Company  
 Address: 2245 Delany Rd.  
 Waukegan, IL  
 Phone: 800.245.7224  
 Fax: 800.245.8224  
 Email: sales@hwilson.com  
 web: www.hwilson.com  
September 2010 - Rev00



### Hardware List:

- A. 1 - 27 x 23.5 Base Plate
- B. 2 - Chrome Tubes (30", 44" or 60" Length)
- C. 1 - Upper Tube Bracket
- D. 1 - WFST Universal Flat Panel Mount
- E. 8 - M8 Set Screws
- F. 4 - M8 Button Head Screws
- G. 4 - M8 Washers
  
- I. 1 - 4 mm Allen Wrench
- J. 1 - 5 mm Allen Wrench
- K. 1 - Caster Set (2 w/ Brake - 2 w/o Brake)
- L. 4 - M10 Acorn Nuts
- M. 4 - M10 Lock Washers
- N. 8 - M10 Washers

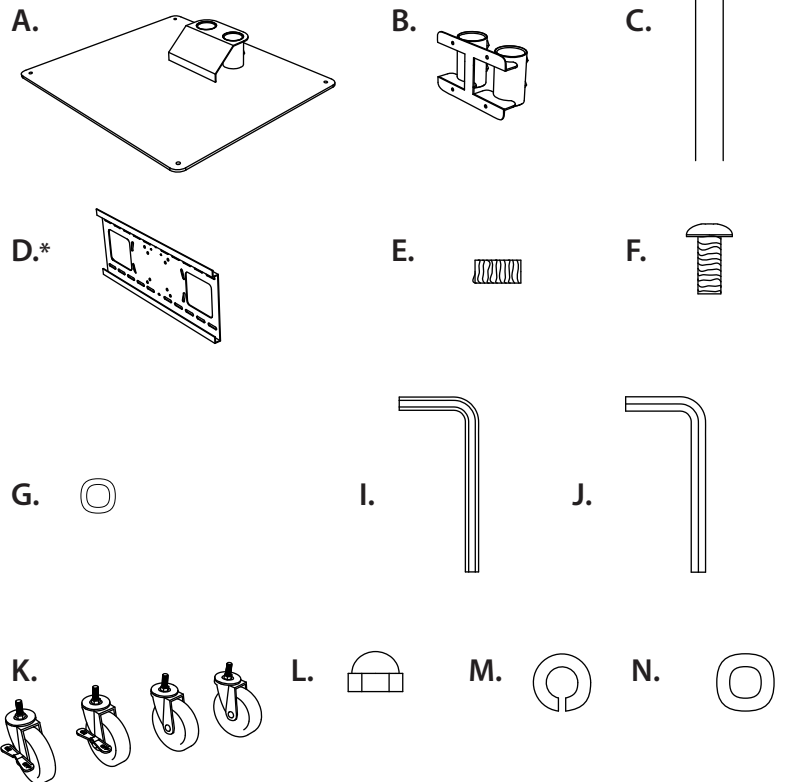

' = Tube Length varies by Model.

'' = K, L, M and N are only included with Models with a -4 designation.

\* = WFST Main Bracket (located in WFST box)

**Tools Required: 2 - 17mm wrenches**

# 1 This step requires 2 people.

Go to step 2 if your model number does not have a -4 designation.

Hardware Used: A (Base Plate), K (Caster Set), L (4 - Acorn Nuts), M (4 - Lock Washers) and N (8 - Washers).

Tools Required: 2 - 17mm wrenches.

Order of Hardware Assembly: Caster(K), M10 Washer(N), Base Plate(A), M10 Washer(N), M10 Lock Washer(M) and Acorn Nut(L).  
With assistance, attach the casters to the base plate following the order of hardware assembly list above.  
Using the 17mm wrenches, tighten the assembly until the lock washer compresses.

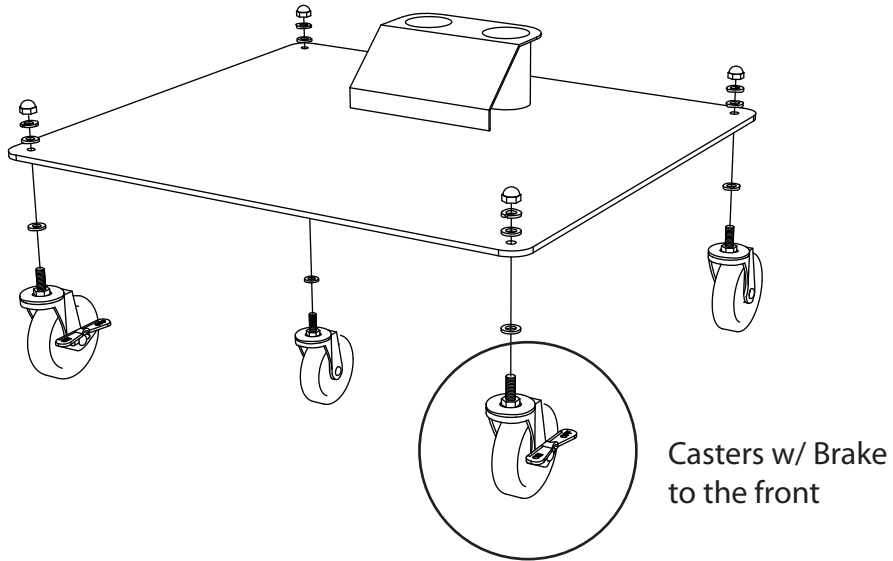

# 2 Hardware Used: B (2 - Chrome Tubes), E (4 - Set Screws) and I (4mm Allen Wrench).

Insert the chrome tubes (B) into the base plate (A).

Insert 4 - set screws (E) into the base plate.

With the 4mm allen wrench (I), tighten the set screws until the chrome tubes are secure.

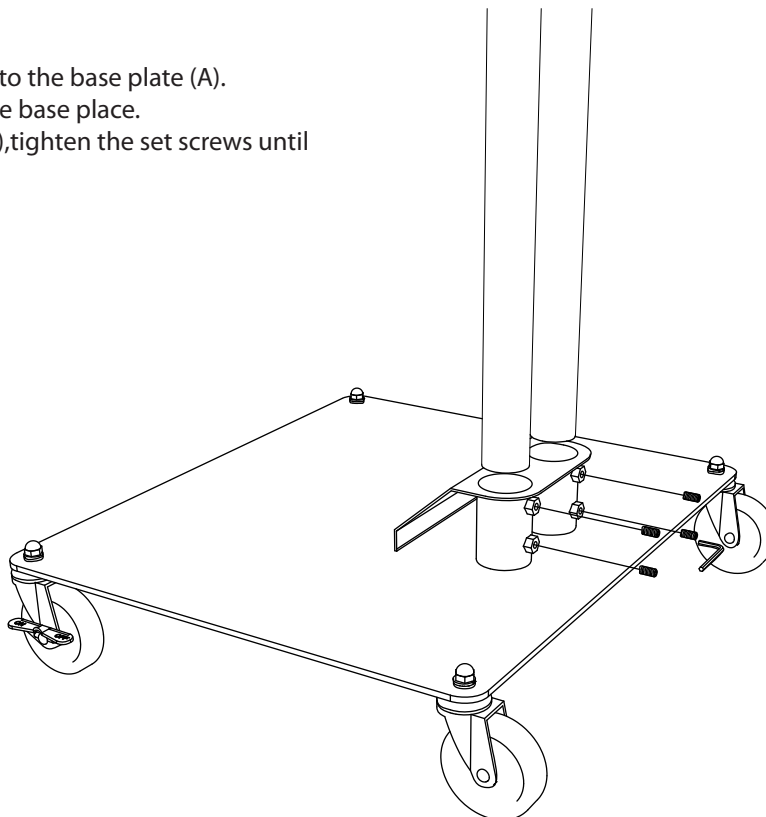

# 3

Hardware Used: C (Upper Bracket), E (4 - Set Screws) and I (4mm Allen Wrench).

Place the upper bracket (C) onto the chrome tubes(B).  
Insert 4 set screws (E), and tighten with the 4mm allen wrench (I) until secure.  
Make sure the bracket (C) is at least 3" below the top of the chrome tubes (B).

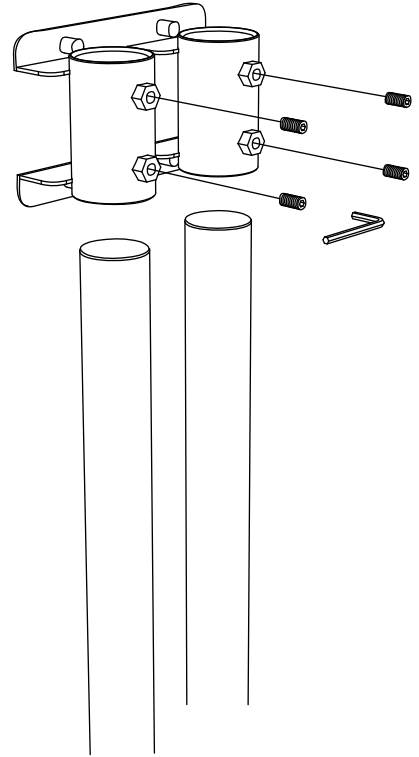

# 4

Hardware Used: D (WFST Main Plate), F (4 - Button Head Screws), G (4 - Washers) and J (4mm Allen Wrench).

Order of Hardware Assembly: Button head screw (F), washer (G), WFST plate (D) and upper bracket (C).  
Using the order of assembly above, attach the WFST plate (D) to the upper bracket (C).  
Using the 4mm allen wrench (J), tighten the button head screws (F) until the lock washer (H) compresses.

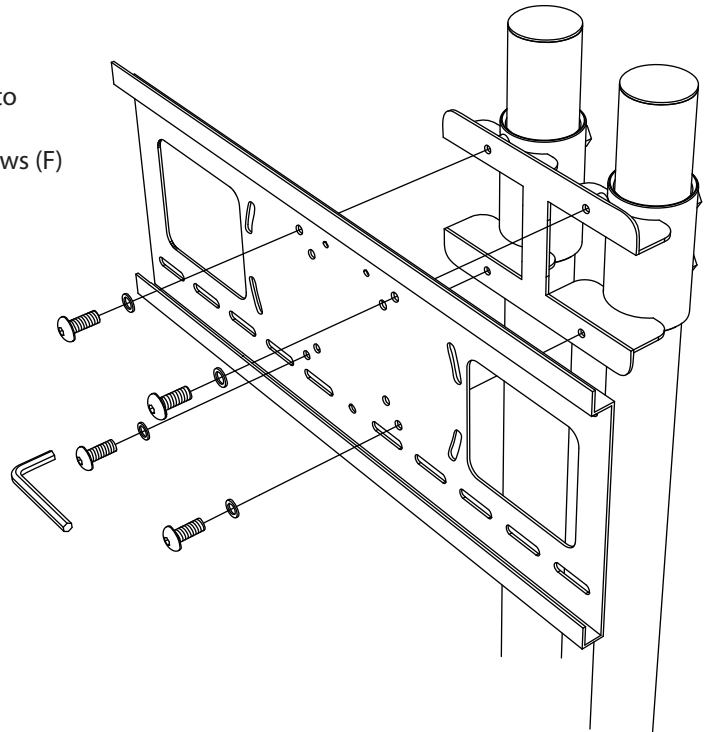

# 5

Follow the instructions provided in the WTFS box to complete the assembly.