

SC551GL

SC5 Series Flat Panel Cart for 42" to 56" Flat Panel Displays



The Peerless-AV SC551GL Floor Cart is designed to provide the ideal display viewing position, centralize audio video components and match the décor of any environment - boardrooms, training rooms, lobbies, classrooms, auditoriums, or exhibit halls. The SC551GL is a perfect solution whether video conferencing from a boardroom or presenting on a trade show floor. Internal cable management hides the AV cabling, showing a clean, clutter-free look.

FEATURES

- Compact design offers personalized computing and video conferencing
- Universal mounting pattern from 200 x 200mm up to 600 x 400mm
- Display tilt adjustment of -5°/+15° for desired viewing angle
- Continuous vertical adjustment of 11.8" for the perfect viewing height
- Adjustable tempered glass shelf for AV components and accessories
- Completely hides cables giving a clean and professional look
- 2.5" swivel casters with two locking casters
- Assembly hardware included



Display size: 42" - 56"



Max load: 66lb (30kg) display
25lb (11kg) shelf

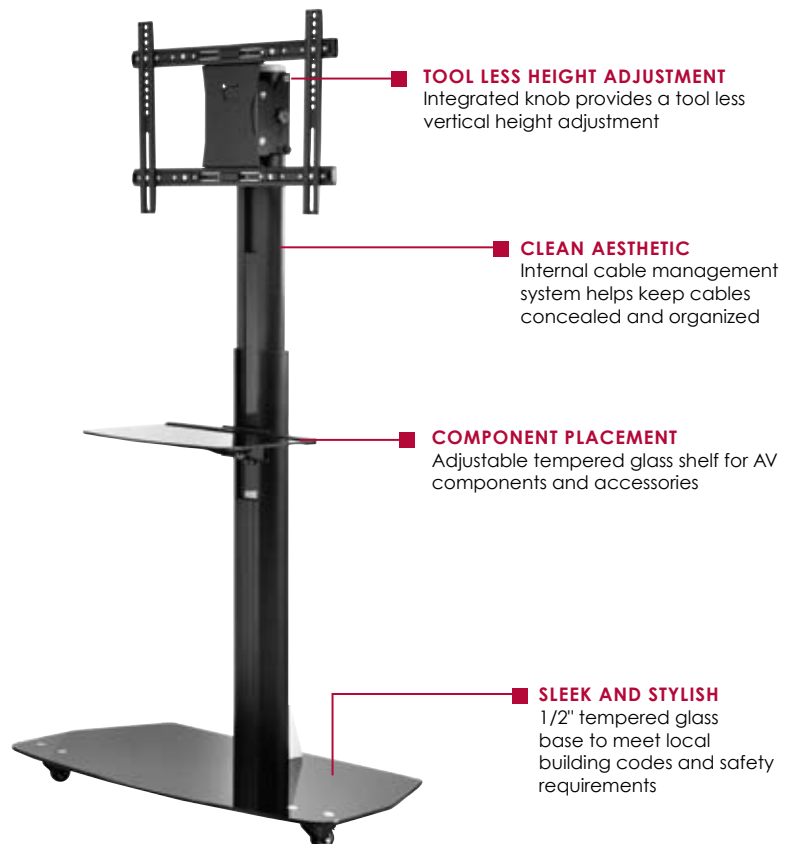

TOOL LESS HEIGHT ADJUSTMENT

Integrated knob provides a tool less vertical height adjustment

CLEAN AESTHETIC

Internal cable management system helps keep cables concealed and organized

COMPONENT PLACEMENT

Adjustable tempered glass shelf for AV components and accessories

SLEEK AND STYLISH

1/2" tempered glass base to meet local building codes and safety requirements



RoHS
2002/95/EC

SC551GL C5 Series Flat Panel Cart for 42" to 56" displays up to 66lb (30kg)

Product Specifications

	DIMENSIONS (W x H x D)	PRODUCT WEIGHT	LOAD CAPACITY	FINISH	AVAILABLE COLORS
SC551GL	34.6" x 75.1" x 34.6" (878 x 1907 x 878mm)	84.4lb (38.3kg)	91lb (41kg) 66lb (30kg) display 25lb (11kg) shelf	Powder Coat	Black

Package Specifications

	PACKAGE SIZE (W x H x D)	PACKAGE SHIP WEIGHT	PACKAGE UPC CODE	PACKAGE CONTENTS	UNITS IN PACKAGE
SC551GL	Box 1: 73.5" x 9.5" x 6" (1867 x 241 x 152mm) Box 2: 41" x 21.5" x 3.75" (1041 x 546 x 95mm)	95lb (43kg)	735029277118	Cart, metal or tinted glass shelf, adapter plate, assembly and display attachment hardware	1

All dimensions = inch (mm)

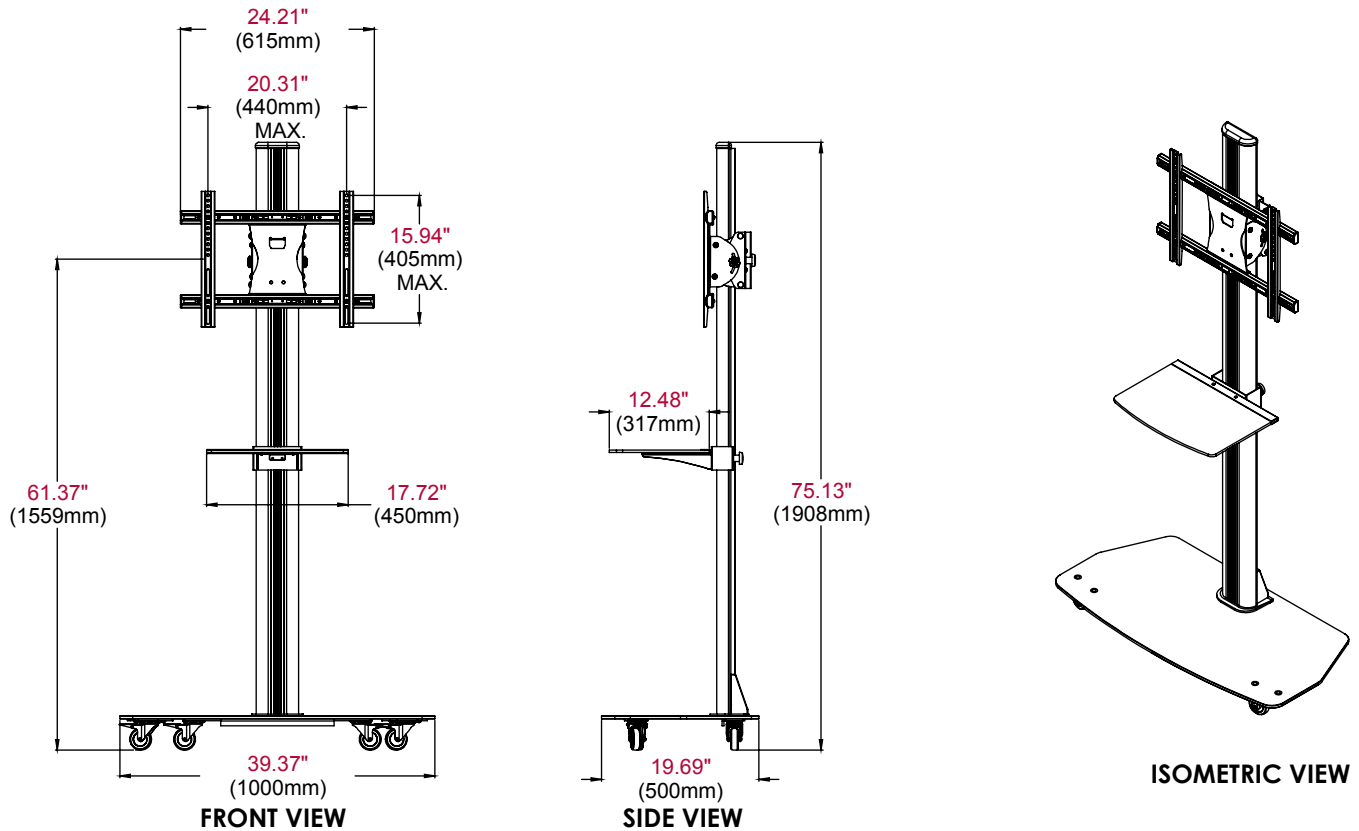

ARCHITECTS SPECIFICATIONS

C5 Series Flat Panel Cart shall be a Peerless-AV model SC551GL and shall be located where indicated on the plans. It shall be finished in black. Assembly and installation shall be done according to instructions provided by the manufacturer.

Peerless Industries, Inc. ■ 2300 White Oak Circle ■ Aurora, IL 60502 ■ (800) 865-2112 ■ (630) 375-5100 ■ Fax: (800) 359-6500 ■ www.peerless-av.com

Visit www.peerless-av.com to see the complete line of AV solutions from Peerless-AV, including flat panel mounts, projector mounts, carts/stands, furniture, cables, screen cleaners and a full assortment of accessories.