

# SC550 SC550GL

## SC5 Series Flat Panel Carts for 42" to 58" Flat Panel Displays

The Peerless-AV SC550 and SC550GL Floor Cart is designed to provide the ideal display viewing position, centralize audio video components and match the décor of any environment - boardrooms, training rooms, lobbies, classrooms, auditoriums, or exhibit halls. Both carts offer a perfect solution whether video conferencing from a boardroom or presenting on a trade show floor. Internal cable management hides the AV cabling, showing a clean, clutter-free look.



### FEATURES

- Compact design offers personalized computing and video conferencing
- Universal mounting pattern from 200 x 200mm up to 600 x 400mm
- Display tilt adjustment of -5°/+15° for desired viewing angle
- Continuous vertical adjustment of 11.8" for the perfect viewing height
- Adjustable tempered glass shelf for AV components and accessories
- Completely hides cables giving a clean and professional look
- 2.5" swivel casters with two locking casters
- Assembly hardware included



Display size: 42" - 58"



Max load: 125lb (56.7kg) display  
25lb (11kg) shelf

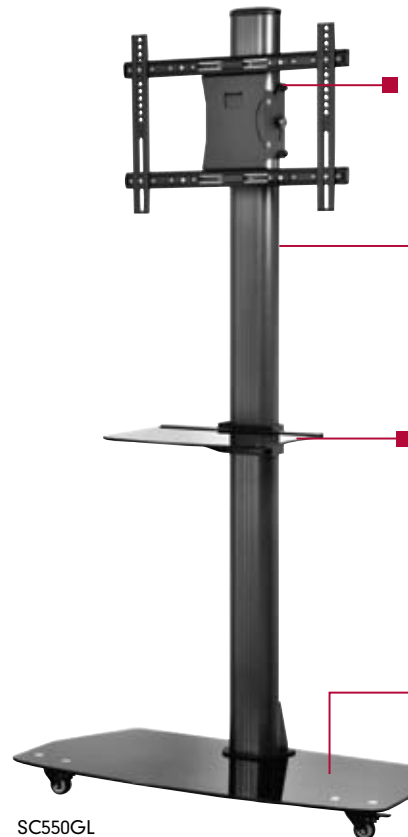

SC550GL

#### TOOL LESS HEIGHT ADJUSTMENT

Integrated knob provides a tool less vertical height adjustment

#### CLEAN AESTHETIC

Internal cable management system helps keep cables concealed and organized

#### COMPONENT PLACEMENT

Adjustable tempered glass shelf for AV components and accessories

#### SLEEK AND STYLISH

1/2" tempered glass base to meet local building codes and safety requirements



SC550



**RoHS**  
2002/95/EC

## Model Numbers

**WARRANTY:** Limited 5-year

<b>SSC550</b>	C5 Series Flat Panel Cart for 42" to 58" displays up to 125lb (56.7kg)
<b>SC550GL</b>	C5 Series Flat Panel Cart for 42" to 58" displays up to 125lb (56.7kg)

## Product Specifications

	DIMENSIONS (W x H x D)	PRODUCT WEIGHT	LOAD CAPACITY	FINISH	AVAILABLE COLORS
<b>SC550</b>	34.6" x 75.1" x 34.6" (878 x 1907 x 878mm)	93.3lb (42.3kg)	150lb (68kg)	Powder Coat	Black
<b>SC550GL</b>	34.6" x 75.1" x 34.6" (878 x 1907 x 878mm)	75.6lb (34.3kg)	125lb (56.7kg) display 25lb (11kg) shelf		

## Package Specifications

	PACKAGE SIZE (W x H x D)	PACKAGE SHIP WEIGHT	PACKAGE UPC CODE	PACKAGE CONTENTS	UNITS IN PACKAGE
<b>SC550</b>	Box 1: 73.5" x 9.5" x 6" (1867 x 241 x 152mm) Box 2: 35.6" x 27.4" x 3.35" (904 x 696 x 85mm)	104lb (47.18kg)	735029277095	Cart, metal or tinted glass shelf, adapter plate, assembly and display attachment hardware	1
<b>SC550GL</b>	Box 1: 73.5" x 9.5" x 6" (1867 x 241 x 152mm) Box 2: 41" x 21.5" x 3.75" (1041 x 546 x 95mm)	85lb (38.7kg)	735029277101		

All dimensions = inch (mm)

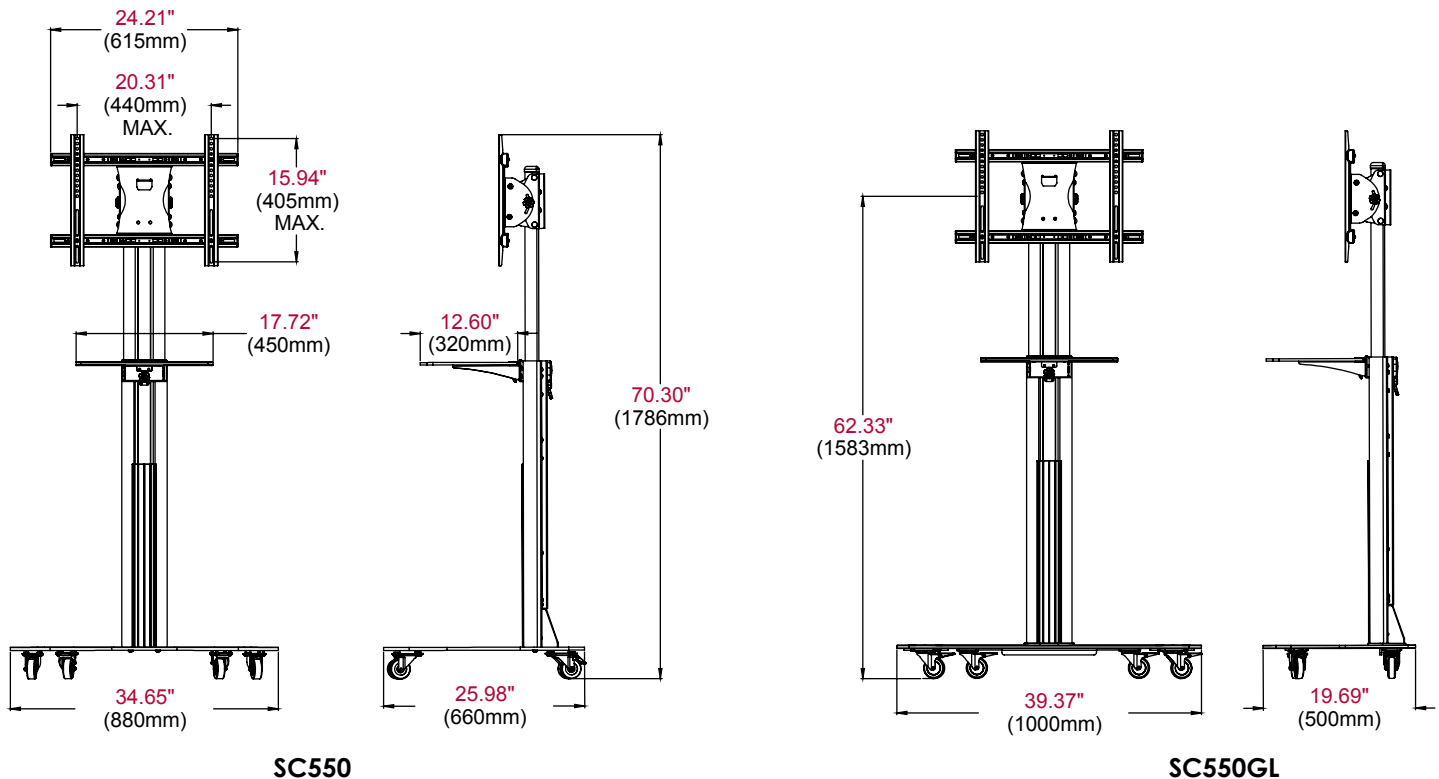

## ARCHITECTS SPECIFICATIONS

C5 Series Flat Panel Carts shall be Peerless-AV models SC550/SC550GL and shall be located where indicated on the plans. It shall have a 125lb load capacity with a 25lb max for the shelf. It shall be finished in black. Assembly and installation shall be done according to instructions provided by the manufacturer.

Peerless Industries, Inc. ■ 2300 White Oak Circle ■ Aurora, IL 60502 ■ (800) 865-2112 ■ (630) 375-5100 ■ Fax: (800) 359-6500 ■ [www.peerless-av.com](http://www.peerless-av.com)

Visit [www.peerless-av.com](http://www.peerless-av.com) to see the complete line of AV solutions from Peerless-AV, including flat panel mounts, projector mounts, carts/stands, furniture, cables, screen cleaners and a full assortment of accessories.