

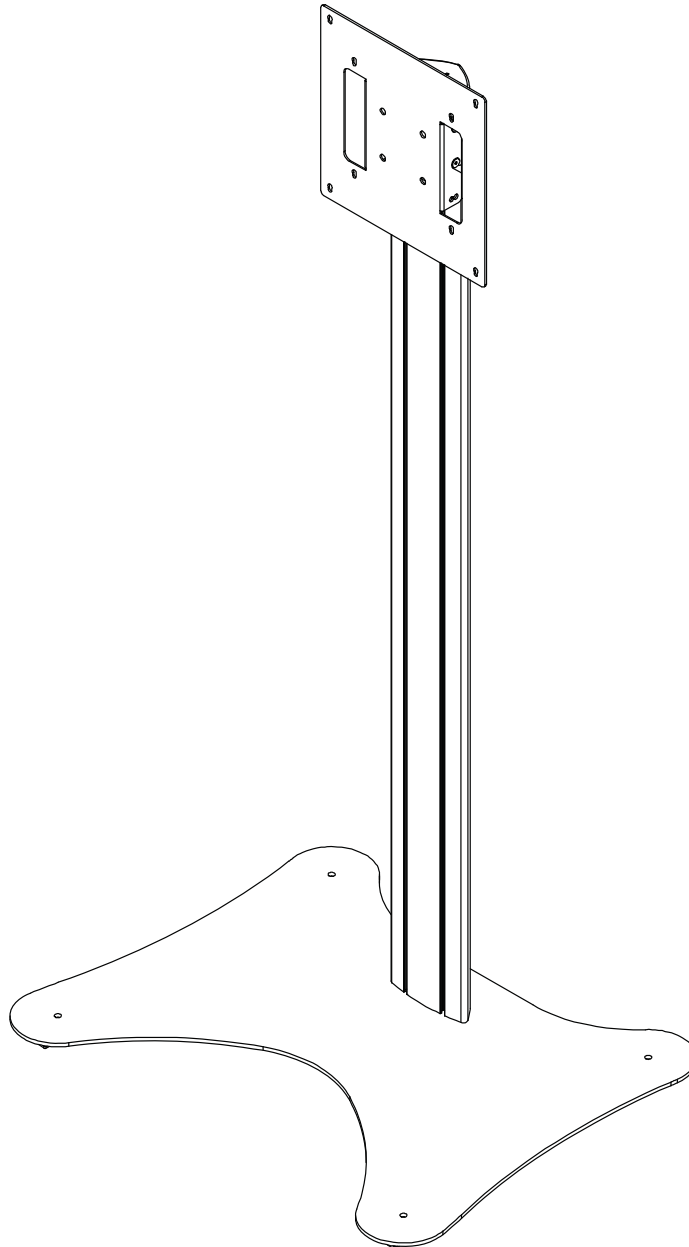

Installation and Assembly: Display Stand for 32" - 60" Flat Panel Displays

Models: SS560F



Max UL Load Capacity: 150 lb (68 kg)

NOTE: Read entire instruction sheet before you start installation and assembly.

WARNING

- Do not begin to install your Peerless product until you have read and understood the instructions and warnings contained in this Installation Sheet. If you have any questions regarding any of the instructions or warnings, please call Peerless customer care at 1-800-865-2112.
- This product should only be installed by someone of good mechanical aptitude, and fully understands these instructions.
- Never exceed the Maximum UL Load Capacity on page 1.
- Always use an assistant or mechanical lifting equipment to safely lift and position equipment.
- Tighten screws firmly, but do not overtighten. Overtightening can damage the items, greatly reducing their holding power.
- The stand is not affixed or secured to the floor, and may therefore tip over and/or fall if display and/or stand is shaken or hit. Always monitor children and do not let children play alone around stand as they could get hurt by a falling display. Not recommended for use in areas with heavy traffic.

Tools Needed for Assembly

- level
- phillips screwdriver

Table of Contents

Parts List.....	3
Assembling Floor Stand	4
Attaching Display using VESA 200 or VESA 300 Mounting Pattern.....	6

Before you begin, make sure all parts shown are included with your product.

Parts List		SS560F
Description	Qty.	Part #
A base	1	009-1407
B upright	1	009-1413
C display mounting bracket	1	201-1156
D adapter plate	1	009-1414
E top cover	1	590-1210
F 3/8-16 x 2.5" button socket cap screw	3	520-9550
G 1/4-20mm nut	6	530-1050
H 1/4-20 x 12mm decorative screw	10	520-2325
I 4mm allen wrench	1	560-9646
J 7/32" allen wrench	1	560-9715
K M10 x .402 ID washer	3	540-9424

Some parts may appear slightly different than illustrated.

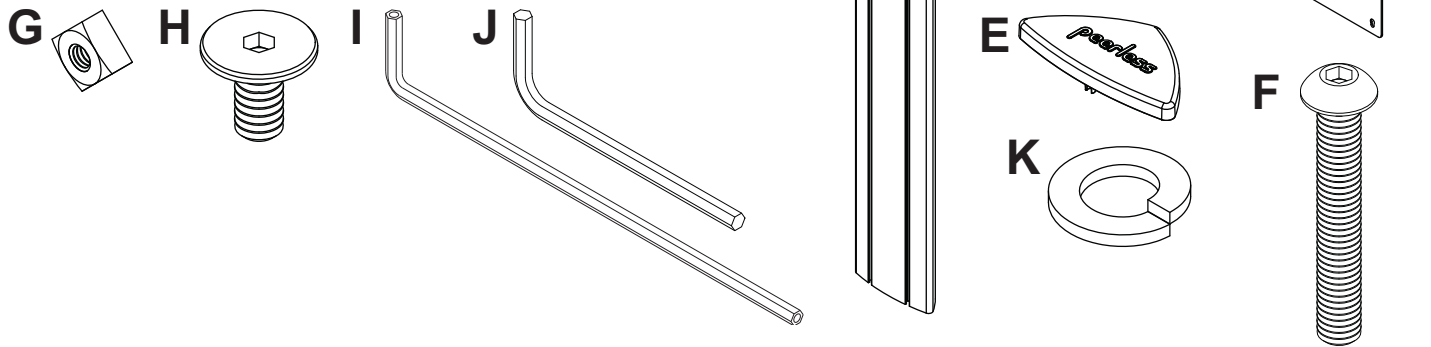

Adapter Plate Fasteners

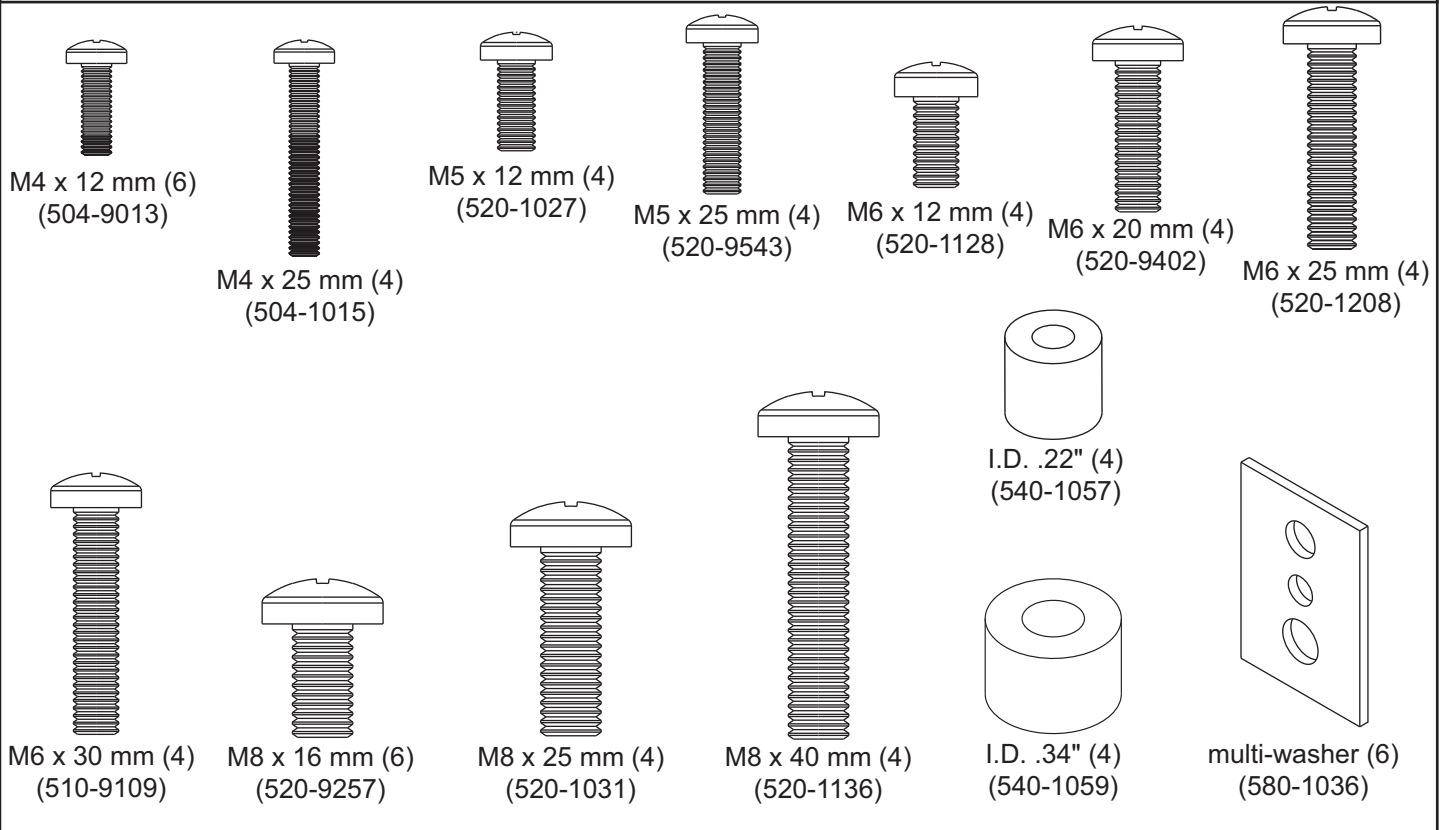

- 1 Attach upright (B) to base (A) with three 3/8-16 x 2.5" socket screws (F) and three M10 washers (K) as shown in figure 1.1. Tighten screws using 7/32" allen wrench (J). Run cords through upright (B) using cord management holes as shown in figure 1.2.

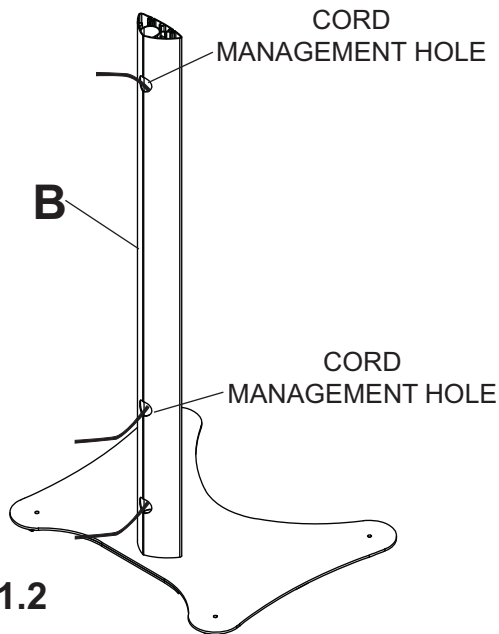
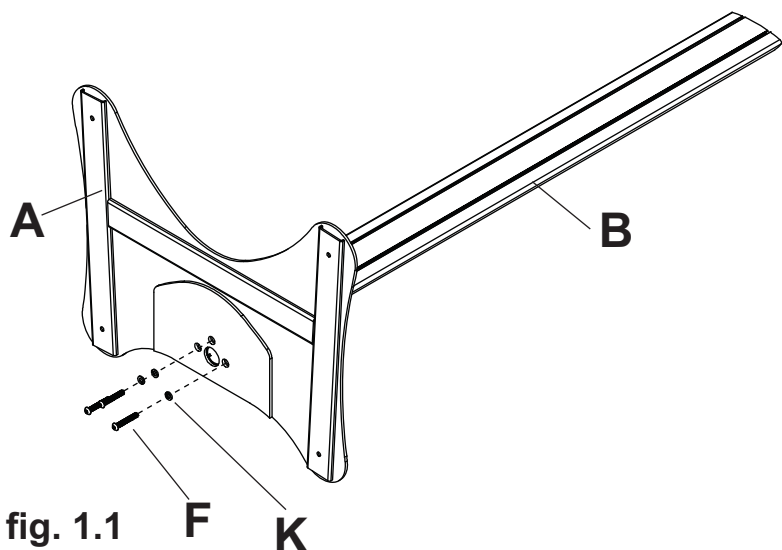

- 2 Loosely attach six 1/4-20 x 12 mm screws (H) and 1/4-20 nuts (G) to display mounting bracket (C).

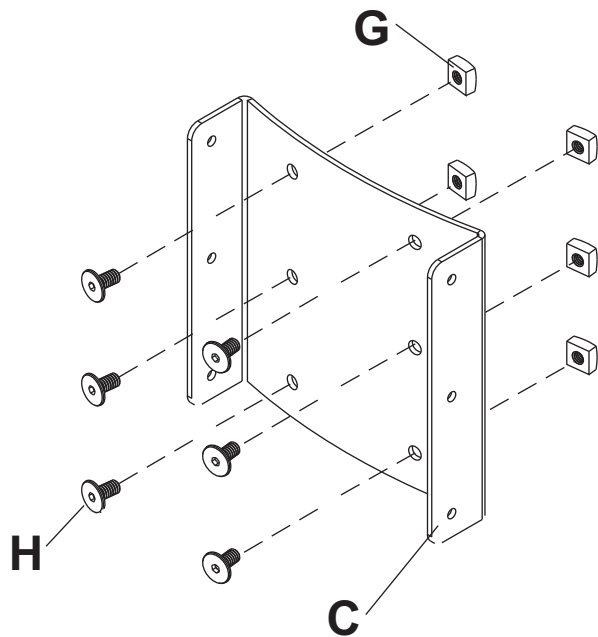

- 3 Slide display mounting bracket (C) onto upright (B) so that 1/4-20 nuts (G) slide into slots of upright (B) as shown in figure 3.1 and detail 1. Slide display mounting bracket to desired position, level, then tighten 1/4-20 x 12 mm screws (H) using 4 mm allen wrench (I).

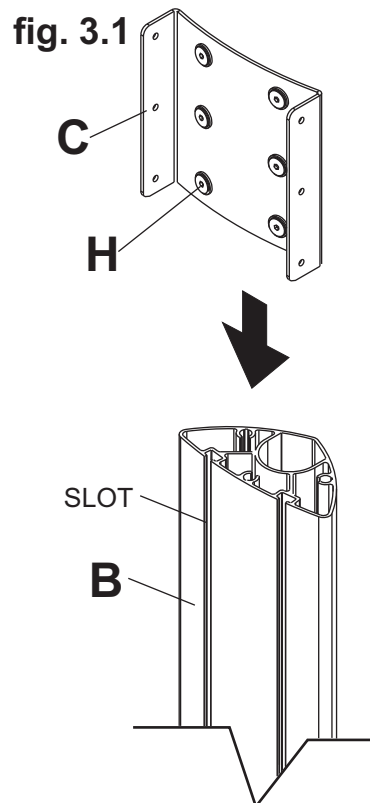
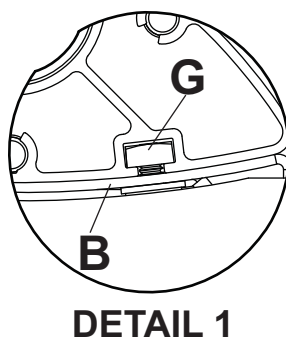

4 Snap top cover (E) onto upright (B).

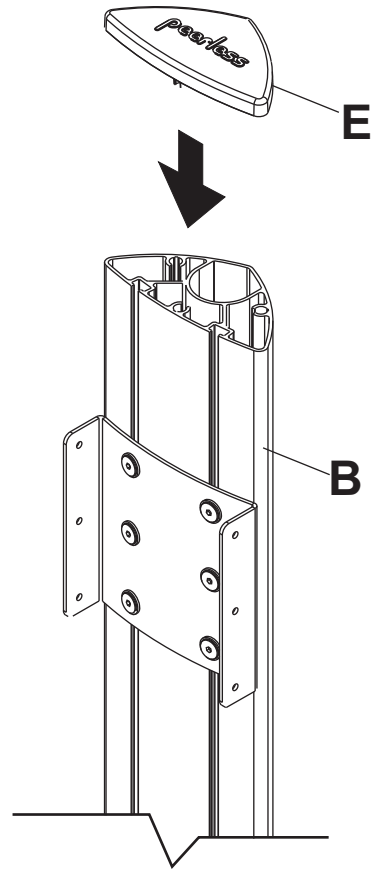

5 Insert two 1/4-20 x 12 mm screws (H) into display mounting bracket (C), leaving 1/8" of exposed thread as shown in figure 5.1 and detail 2.

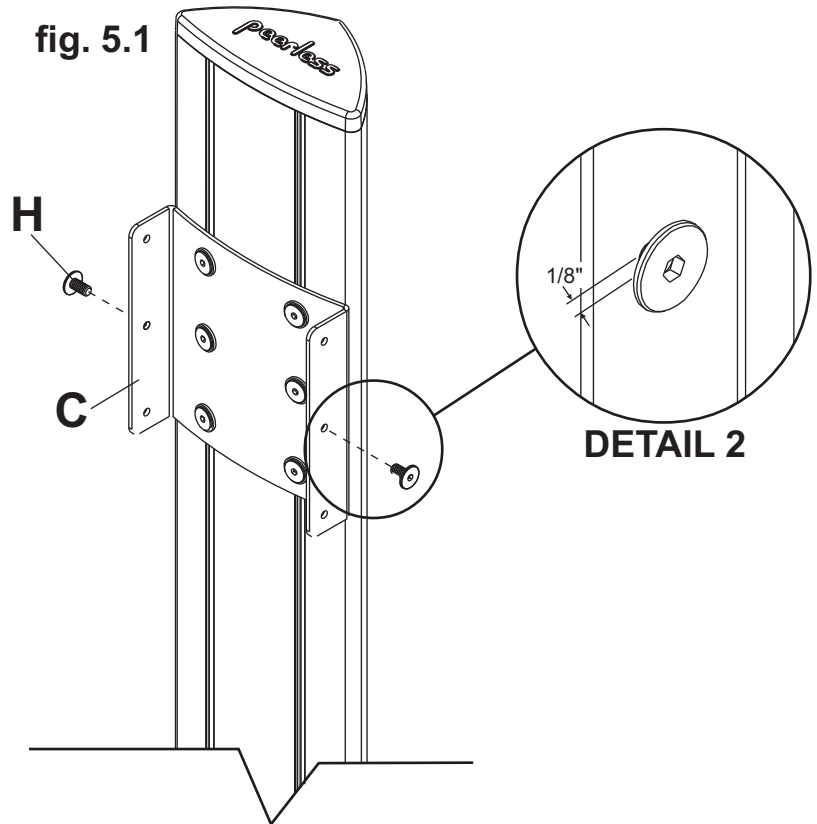

Installing Adapter Plate

⚠ WARNING

- Tighten screws so adapter plate is firmly attached. Do not tighten with excessive force. Overtightening can cause stress damage to screws, greatly reducing their holding power and possibly causing screw heads to become detached. Tighten to 40 in. • lb (4.5 N.M.) maximum torque.
- If screws don't get three complete turns in the display inserts or if screws bottom out and adapter plate is still not tightly secured, damage may occur to display or product may fail.

6 To prevent scratching the display, set a cloth on a flat, level surface that will support the weight of the display. Place display face side down. If display has knobs on the back, remove them to allow the adapter plates to be attached. Place adapter plate (**D**) on back of display, align to holes, and center on back of display as shown below. Attach the adapter plates to the back of the display using the appropriate combination of screws, multi-washers, and spacers as shown in figure 6.1 or 6.2.

NOTE: Top and bottom mounting holes on display must be used for attaching brackets.

NOTE: Verify that all holes are properly aligned, and then tighten screws using a phillips screwdriver.

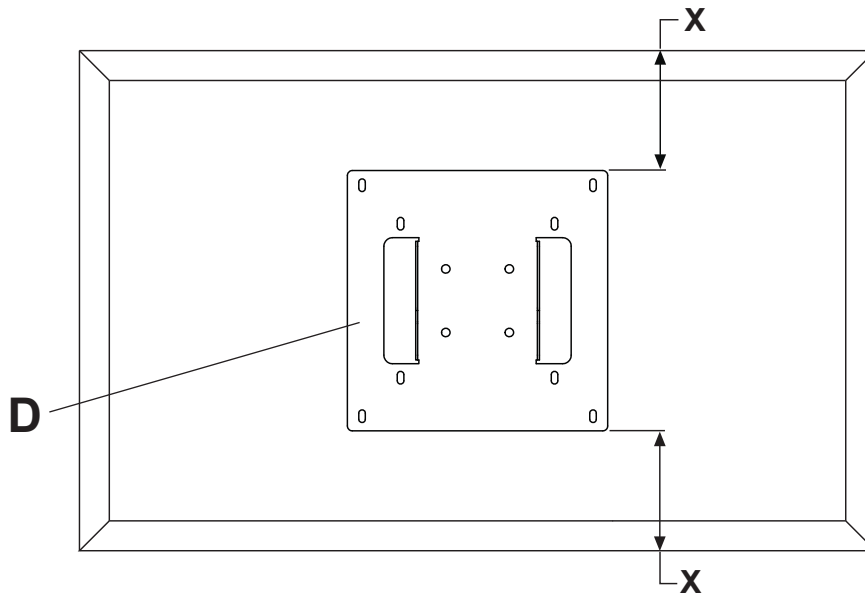

NOTE: "X" dimensions should be equal.

MULTI-WASHER

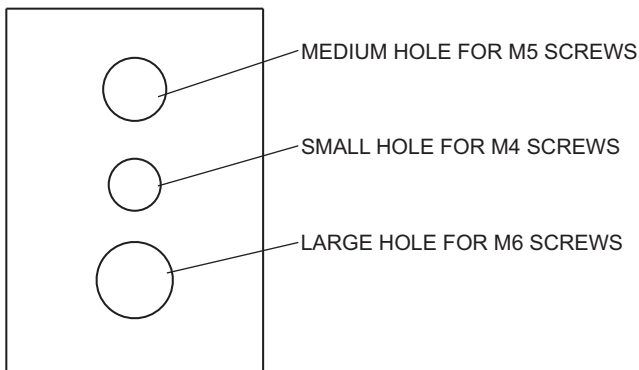

NOTES:

- The number of fasteners used will vary, depending upon the type of display.
- Multi-washers and spacers may not be used, depending upon the type of display.
- Use the corresponding hole in the multi-washer that matches your screw size as shown.

NOTE: For **flat back displays** proceed to step 6-1. For **bump-out or recessed back display** skip to step 6-2.

Attaching Display using VESA 200 or VESA 300 Mounting Pattern

⚠ WARNING

- If screws don't get three complete turns in the display inserts or if screws bottom out and adapter plate is still not tightly secured, damage may occur to display or product may fail.

For Flat Back Display

- 6-1** Select the screws from the baffled fastener pack that best fit your display. Begin with the shortest length screw, hand thread through multi-washer and adapter plate (D) into display as shown below. Screw must make at least three full turns into the mounting hole and fit snug into place. Do not over tighten. If screw cannot make three full turns into the display, select a longer length screw from the baffled fastener pack. Repeat for remaining mounting holes and tighten screws.

NOTE: Spacers may not be used, depending upon the type of display.

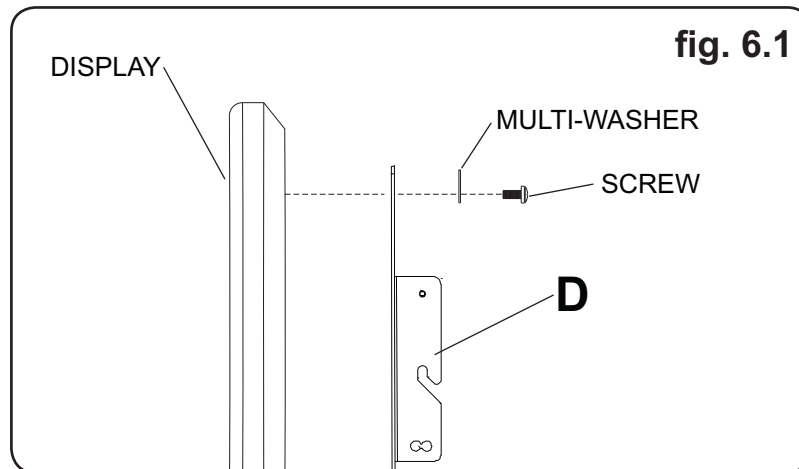

If you have any questions, please call Peerless customer care at 1-800-865-2112.

For Bump-out or Recessed Back Display

- 6-2** Select the screws from the baffled fastener pack that best fit your display. Begin with longer length screw, hand thread through multi-washer, adapter plate (D) and spacer in that order into display as shown below. Screw must make at least three full turns into the mounting hole and fit snug into place. Do not over tighten. If screw cannot make three full turns into the display, select a longer length screw from the baffled fastener pack. Repeat for remaining mounting holes and tighten screws.

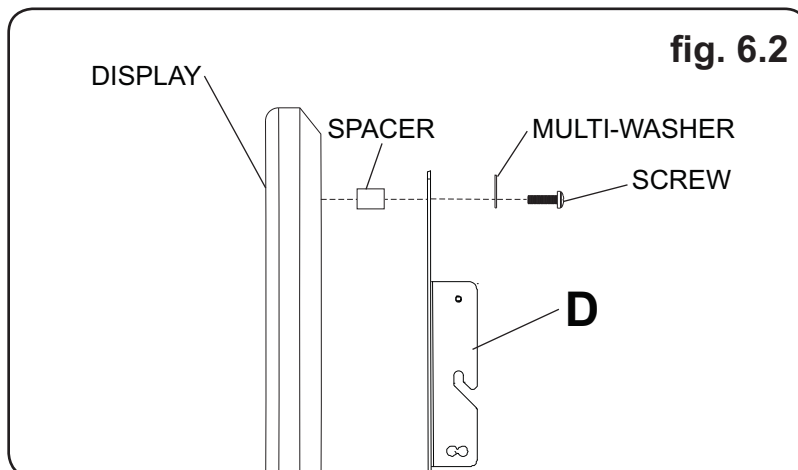

If you have any questions, please call Peerless customer care at 1-800-865-2112.

- 7** Attach adapter plate (**D**) to display mounting bracket (**C**).

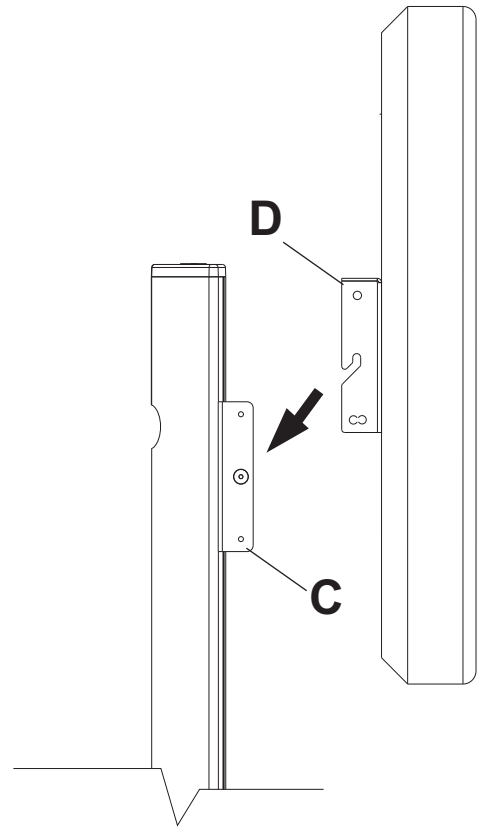

- 8** Insert two 1/4-20 x 12 mm screws (**H**) into holes indicated below for desired display orientation. Tighten all screws using 4 mm allen wrench (**I**).

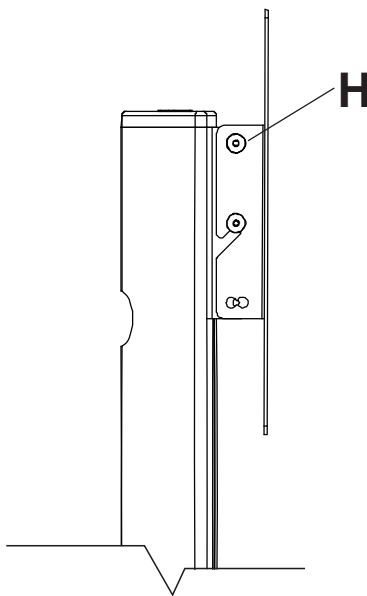

No Tilt

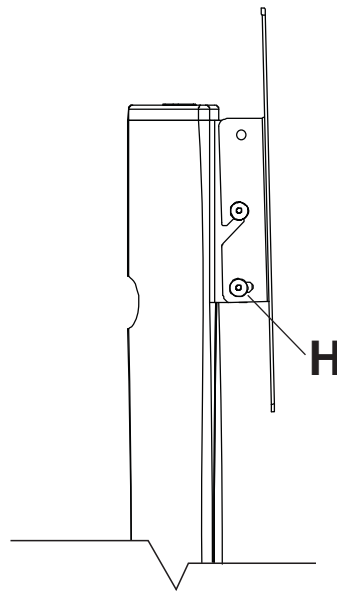

2° Backward Tilt

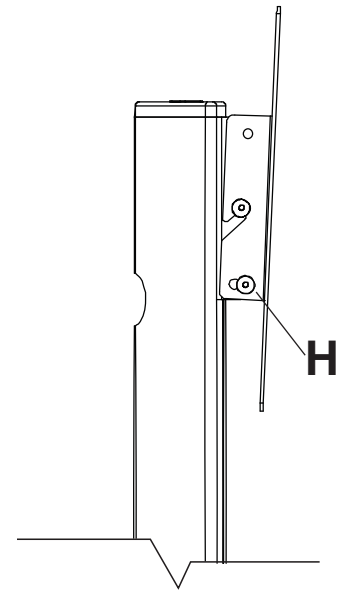

5° Forward Tilt

LIMITED FIVE-YEAR WARRANTY

Peerless Industries, Inc. ("Peerless") warrants to original end-users of Peerless® products will be free from defects in material and workmanship, under normal use, for a period of five years from the date of purchase by the original end-user (but in no case longer than six years after the date of the product's manufacture). At its option, Peerless will repair or replace, or refund the purchase price of, any product which fails to conform with this warranty.

In no event shall the duration of any implied warranty of merchantability or fitness for a particular purpose be longer than the period of the applicable express warranty set forth above. Some states do not allow limitations on how long an implied warranty lasts, so the above limitation may not apply to you.

This warranty does not cover damage caused by (a) service or repairs by the customer or a person who is not authorized for such service or repairs by Peerless, (b) the failure to utilize proper packing when returning the product, (c) incorrect installation or the failure to follow Peerless' instructions or warnings when installing, using or storing the product, or (d) misuse or accident, in transit or otherwise, including in cases of third party actions and force majeure.

In no event shall Peerless be liable for incidental or consequential damages or damages arising from the theft of any product, whether or not secured by a security device which may be included with the Peerless® product. Some states do not allow the exclusion or limitation of incidental or consequential damages, so the above limitation or exclusion may not apply to you.

This warranty is in lieu of all other warranties, expressed or implied, and is the sole remedy with respect to product defects. No dealer, distributor, installer or other person is authorized to modify or extend this Limited Warranty or impose any obligation on Peerless in connection with the sale of any Peerless® product.

This warranty gives specific legal rights, and you may also have other rights which vary from state to state.

peerless-AV

www.peerlessmounts.com

© 2011 Peerless Industries, Inc.