

## INSTALLATION INSTRUCTIONS

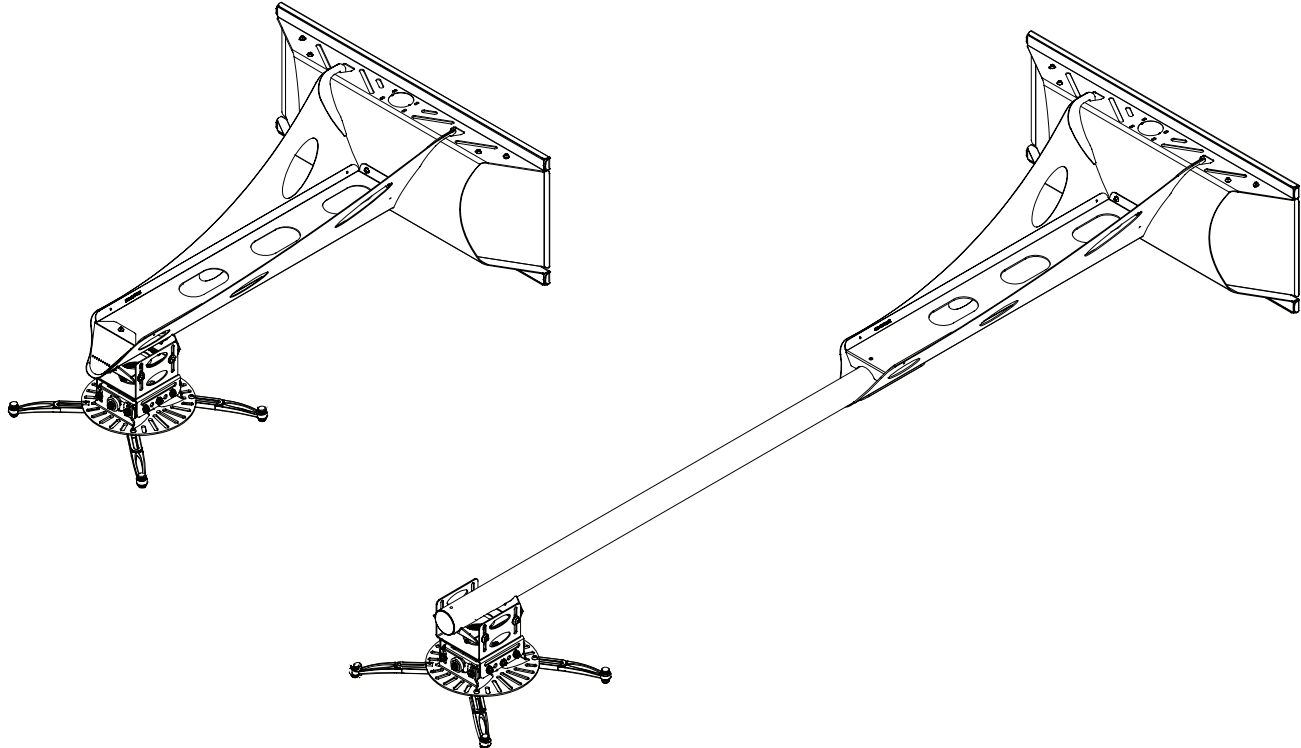

### **Universal Short Throw Projector Arm** Model: UNI-STA/UNI-EXT

---

#### **NORTH AMERICA**

3130 East Miraloma Avenue  
Anaheim, CA 92806 USA  
USA and Canada  
Phone: 1-800-368-9700  
Fax: 1-800-832-4888  
Other Locations  
Phone: (001) 714-632-7100  
Fax: (001) 714-632-1044

#### **EUROPE**

Swallow House,  
Shilton Industrial Estate,  
Shilton, Coventry, England CV79JY  
Phone: +44 (0) 2476 614700  
Fax: +44 (0) 2476 614710



# Table of Contents

- Weight Capacity ..... 2
- Warning Statements ..... 2
- Installation Tools ..... 3
- Parts List ..... 3
- PDS-PLUS-STA/PDS-PLUSW-STA Mounting Hardware ..... 4
- Lock-It™ Security Pack ..... 4
- Determining the Installation Height ..... 5
- Wood Stud Installation ..... 6
- Attaching the Projector Arm ..... 7
- Throw Distance Calculation ..... 8
- Adjustable Mounting Bracket Installation ..... 9
- Attaching the Base Box to the Adjustable Mounting Bracket ..... 10
- Extension Arm Installation (Optional) ..... 10
- Low Profile Bracket Installation ..... 11
- Attaching the Base Box to the Upper Mounting Plate ..... 11
- Attaching the Universal Projector Plate ..... 12
- Attaching the Projector ..... 16
- Set Screw Installation ..... 17
- Utilizing the Storage Feature ..... 17
- Cable Management ..... 18
- Technical Specifications ..... 19
- Warranty ..... 20
- Disclaimer ..... 20

## Weight Capacity

Maximum projector weight: **50 lb.**

THE WALL STRUCTURE MUST BE CAPABLE OF HOLDING FIVE (5) TIMES THE WEIGHT OF THE PROJECTOR. IF NOT, THEN THE WALL STRUCTURE MUST BE REINFORCED.

## Warning Statements

 PRIOR TO THE INSTALLATION OF THIS PRODUCT, THE INSTALLATION INSTRUCTIONS SHOULD BE READ AND COMPLETELY UNDERSTOOD. THE INSTALLATION INSTRUCTIONS MUST BE READ TO PREVENT PERSONAL INJURY AND PROPERTY DAMAGE. KEEP THESE INSTALLATION INSTRUCTIONS IN AN EASILY ACCESSIBLE LOCATION FOR FUTURE REFERENCE.

 PREMIER MOUNTS DOES NOT WARRANT AGAINST DAMAGE CAUSED BY THE USE OF ANY PREMIER MOUNTS PRODUCT FOR PURPOSES OTHER THAN THOSE FOR WHICH IT WAS DESIGNED OR DAMAGE CAUSED BY UNAUTHORIZED ATTACHMENTS OR MODIFICATIONS, AND IS NOT RESPONSIBLE FOR ANY DAMAGES, CLAIMS, DEMANDS, SUITS, ACTIONS OR CAUSES OF ACTION OF WHATEVER KIND RESULTING FROM, ARISING OUT OF OR IN ANY MANNER RELATING TO ANY SUCH USE, ATTACHMENTS OR MODIFICATIONS.

 SAFETY MEASURES MUST BE PRACTICED AT ALL TIMES DURING THE ASSEMBLY OF THIS PRODUCT. USE PROPER SAFETY GEAR AND TOOLS FOR THE ASSEMBLY PROCEDURE TO PREVENT PERSONAL INJURY.

 At least two qualified people should perform the assembly procedure. Injury and/or damage can result from dropping or mishandling the projector.

 If mounting to studs, make sure that the mounting screws are anchored into the center of the studs. Use of an edge-to-edge stud finder is recommended.

 Be aware of the mounting environment. If drilling and/or cutting into the mounting surface, always make sure that there are no electrical wires in wall. Cutting/drilling into an electrical line may cause serious injury.

 Make sure there are no water lines inside the wall where the mount is to be located. Cutting/drilling into a water line may cause severe water damage to the mounting surface.

 This product is intended for indoor use only. Use of this product outdoors could lead to product failure and personal injury.

 Do not install near sources of high heat. Do not install on a structure that is prone to vibration, movement or chance of impact

 Contact Premier Mounts with any questions  
(800) 368-9700  
techsupport@mounts.com



## Installation Tools

The following tools may be required depending upon your particular installation. They are not included.

	<p>Phillips Screwdriver</p>	<p>1/4" Drill Bit</p>	<p>Electronic Stud Finder</p>	<p>Level</p>
	<p>1/2" Socket and Socket Wrench</p>		<p>Drill</p>	











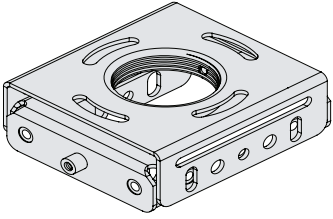
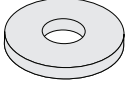
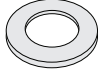

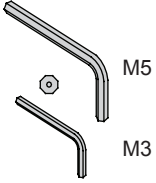
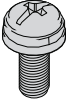









## Parts List

Make sure your Premier Mounts product has the following hardware and components before beginning installation. If there are parts missing and/or damaged, stop the installation and call Premier Mounts at (800) 368-9700.

UNI-STA/UNI-EXT Hardware					
<p>Wall Plate (Qty 1)</p>	<p>Arm Assembly (Qty 1)</p>	<p><b>Extension Hardware Pack</b></p> <p>M6 x 12mm Security (Qty 2)</p> <p>M6 Flat Washer (Qty 2)</p>		<p>Extension Arm - Optional (Qty 1) included with the UNI-EXT</p> <p>Internal Slide Plate (Qty 1)</p>	
<p>End Cover (Qty 1)</p>	<p>Adjustable Mounting Assembly - Pre-Assembled (Qty 1)</p>	<p>External Slide Plate (Qty 1)</p>	<p>Back Plate Covers (Qty 2)</p>		
<p>M5 x 8mm Security Screws (Qty 7)</p>	<p>M6 x 16mm Security Screws (Qty 2)</p>	<p>5/16" x 3" Lag Bolts (Qty 4)</p>	<p>M6 x 12mm Security Screws (Qty 2)</p>	<p>1/8" Nylon Spacer (Qty 2)</p>	<p>Square Washers (Qty 4)</p>
<p>Projector Bracket (Qty 1)</p>		<p>Mounting Legs - Long (Qty 4)</p>		<p>Mounting Legs - Short (Qty 4)</p>	



## Parts List (cont'd)

PDS-PLUS-STA/PDS-PLUSW-STA Mounting Hardware			
Base Box (Qty 1)		Nylon Spacer (Qty 2)	
		Flat Washer (Qty 2)	
External Tooth Washer (Qty 4)		Security Wrenches (Qty 2)	
M6 x 12mm Phillips Head w/Integrated Split Washer (Qty 12; 6 pre-installed)		<b>Lock-It™ Security Pack</b>	
M2.5 x 10mm Phillips Pan Head Screw (Qty 4)		M6 x 12mm Security Head w/Integrated Split Washer (Qty 12)	
M6 x 8mm Set Screw (Qty 1)		M2.5 x 10mm Security Screw (Qty 4)	
M3 Flat Washer (Qty 10)		M6 x 8mm Security Set Screw (Qty 1)	
M2.5 x 12mm Screw (Qty 4)		M3 Flat Washer (Qty 10)	
M3 x 16mm Screw (Qty 4)		M2.5 x 12mm Security Screw (Qty 4)	
M4 x 12mm Screw (Qty 4)		M3 x 16mm Security Screw (Qty 4)	
M5 x 12mm Screw (Qty 4)		M4 x 12mm Security Screw (Qty 4)	
M6 x 12mm Screw (Qty 8)		M5 x 12mm Security Screw (Qty 4)	
1/4" - 20 x 5/16" Screw (Qty 1)		M6 x 12mm Security Screw (Qty 8)	
		1/4" - 20 x 5/16" Security Screw (Qty 1)	



## Determining the Installation Height

In order to determine the installation height and throw distance, the PDS-PLUS projector bracket must be mounted to the projector. Please refer to the PDS-PLUS Installation Instructions prior to performing the following steps.

Refer to the projectors User's Manual to determine the offset of the projector lens to the top of the screen/whiteboard (B).

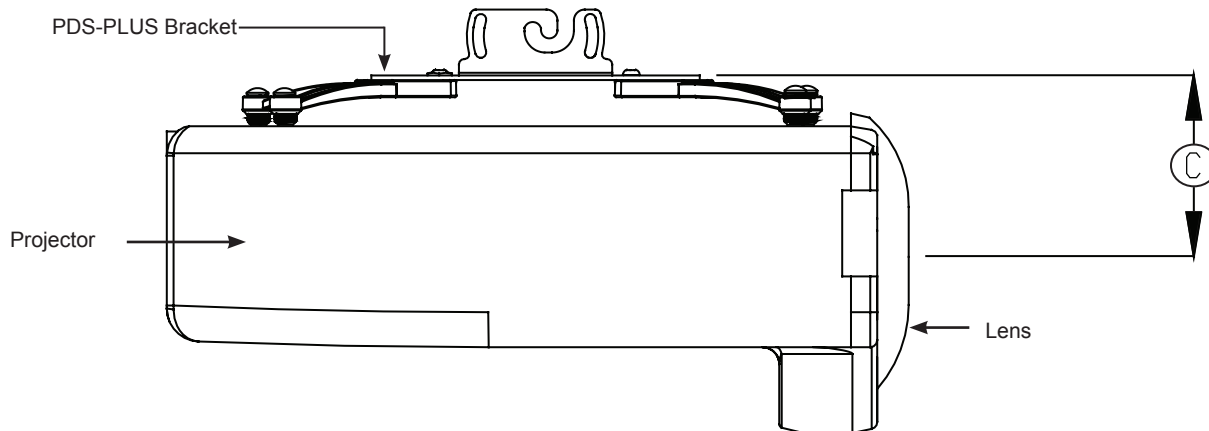

- 1 Measure distance from center of lens to the top of the PDS-PLUS bracket (C).
- 2 Add the distance from the ground to the top of the screen (A). Add the projector manufacturers recommended offset from the projector manual (B). Add the measurement from Step 1 (C), and then add 2.5" to the total.  
(Example:  $A + B + C + 2.5" = ?$ )
- 3 Add the measurements to determine the mounting height mark. Place a mark at the top of the total calculated height measurement starting from the ground up. This mark will represent the lower edge of the wall plate.

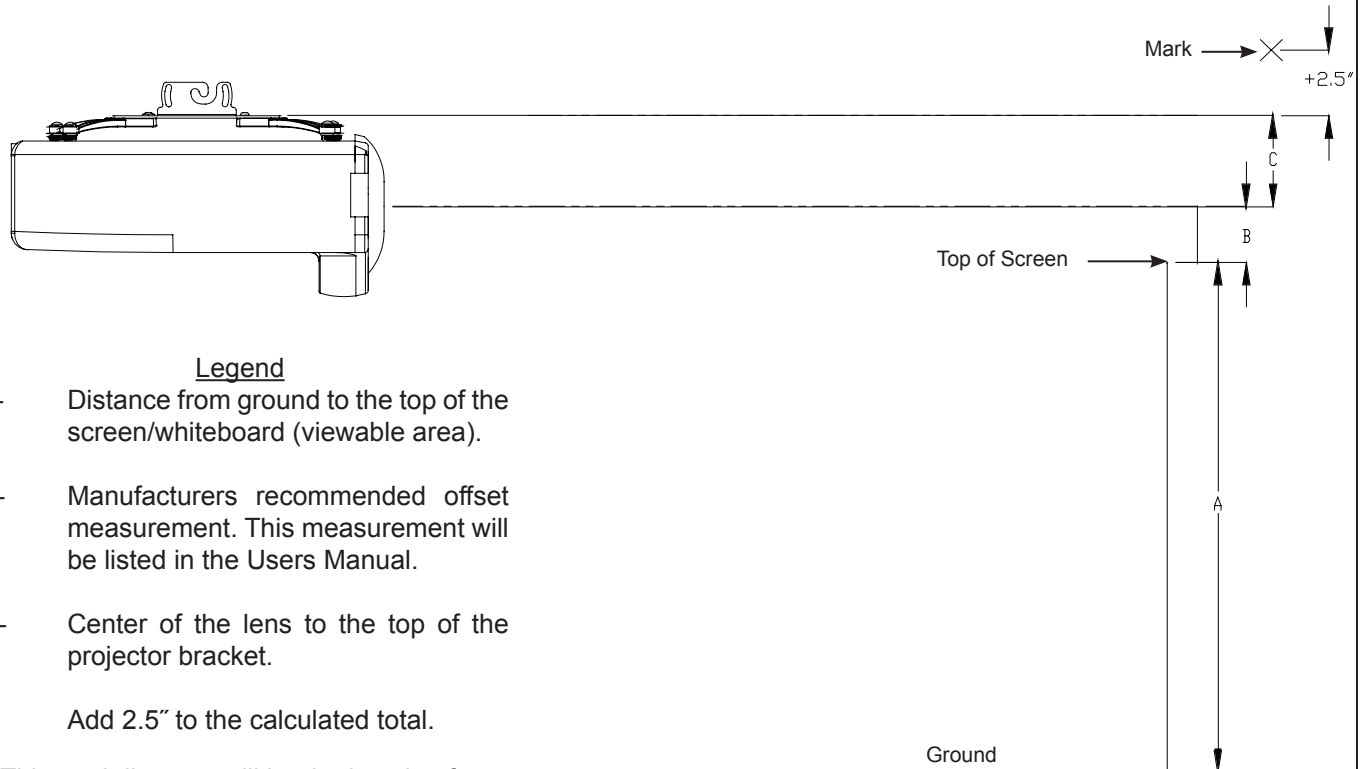

### Legend

- A - Distance from ground to the top of the screen/whiteboard (viewable area).
- B - Manufacturers recommended offset measurement. This measurement will be listed in the Users Manual.
- C - Center of the lens to the top of the projector bracket.

Add 2.5" to the calculated total.

This total distance will be the location for the bottom rail on the wall plate.

Proceed to the **“Wood Stud Installation”** section.



## Wood Stud Installation



Do NOT over-tighten lag bolts when attaching the mount to the wall. Improper installation may result in personal injury or damage to property.



THE EXACT CENTER OF THE STUD MUST BE LOCATED FOR CORRECT AND SAFE INSTALLATION.

### Step 1

Use an electronic stud finder (not supplied) to locate the center of the stud that is in the wall.

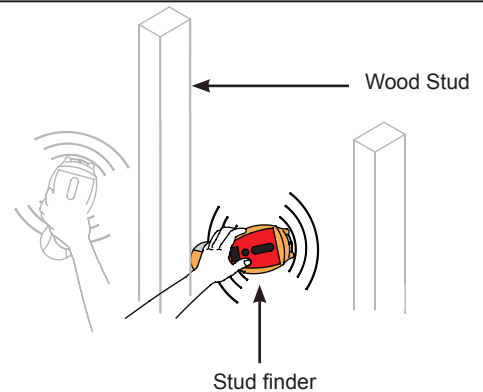

### Step 2

Use a pencil to mark the first mounting point, just above your height mark (from page 5).

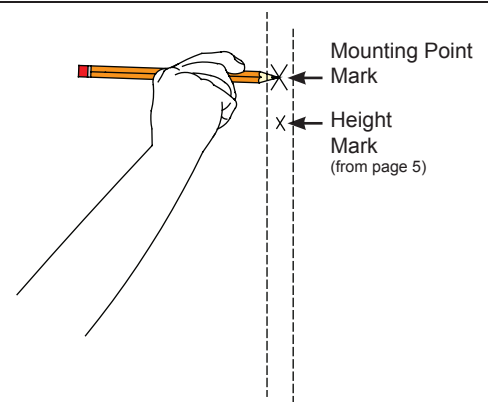

### Step 3

- 1 Use the level to make sure the wall plate is level from side to side.
- 2 Place the wall plate over the first mounting point mark and use a pencil to mark the rest of the mounting points.



Four (4) mounting points must be used. Two (2) upper mounting points and two (2) lower mounting points.

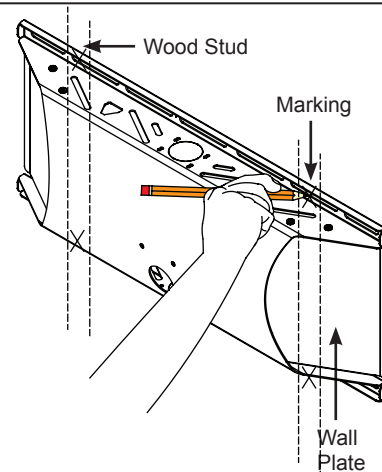

### Step 4

Once the mounting points have been marked, use a 1/4" drill bit and portable drill to drill the pilot holes.

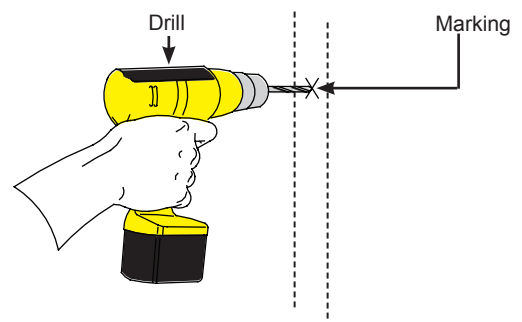



### Step 5

After the pilot holes have been drilled, use four (4)  $\frac{5}{16}$ " x 3" lag bolts and four (4) square washers to mount the wall plate to the wooden studs.

Use a  $\frac{1}{2}$ " socket and socket wrench to finish this step.

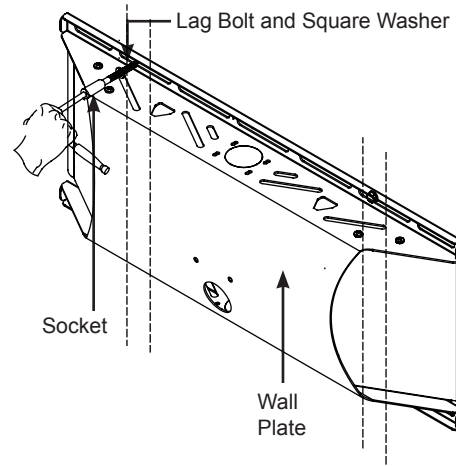

### Step 6

Insert and gently tap the upper and lower back plate covers into place.

Proceed to the "Attaching the Projector Arm" section.

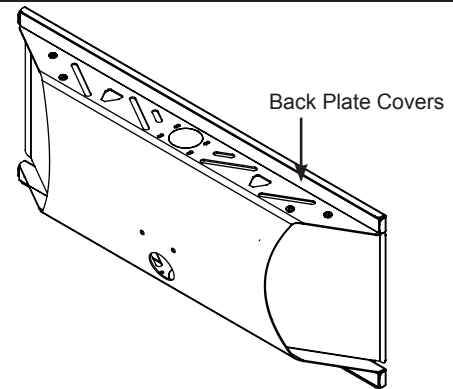

## Attaching the Projector Arm

### Step 1

- 1 Locate the mounting hook cutout on the top of the wall plate.
- 2 Tilt the arm slightly and gently insert the mounting hooks into the mounting hook cutouts.
- 3 Slowly lower and let the projector arm rest against the wall plate.



If using the storage feature of the product, it may be easier to route any wiring at this time (please see Page 12).



**MAKE SURE THE PROJECTOR ARM IS FULLY SEATED BEFORE RELEASING THE UNIT.**

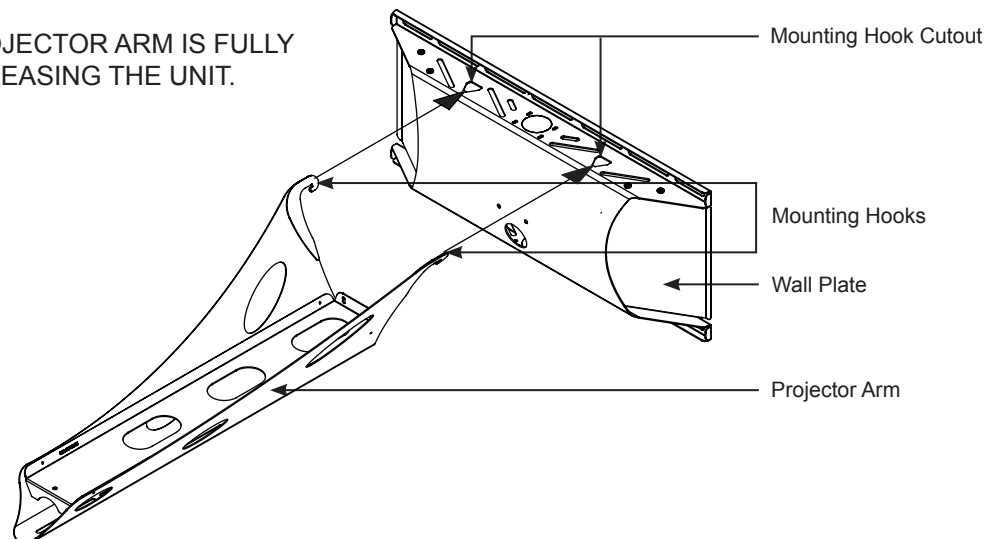

**Step 2**

- 4 Locate the two (2) lock mounting points on the projector arm. These two points will be aligned with the lock mounting points on the wall plate.
- 5 Using a security wrench, insert and tighten two (2) M5 x 8mm security head screws.



Do NOT overtighten these screws.

Proceed to the “**Throw Distance Calculation**” section.

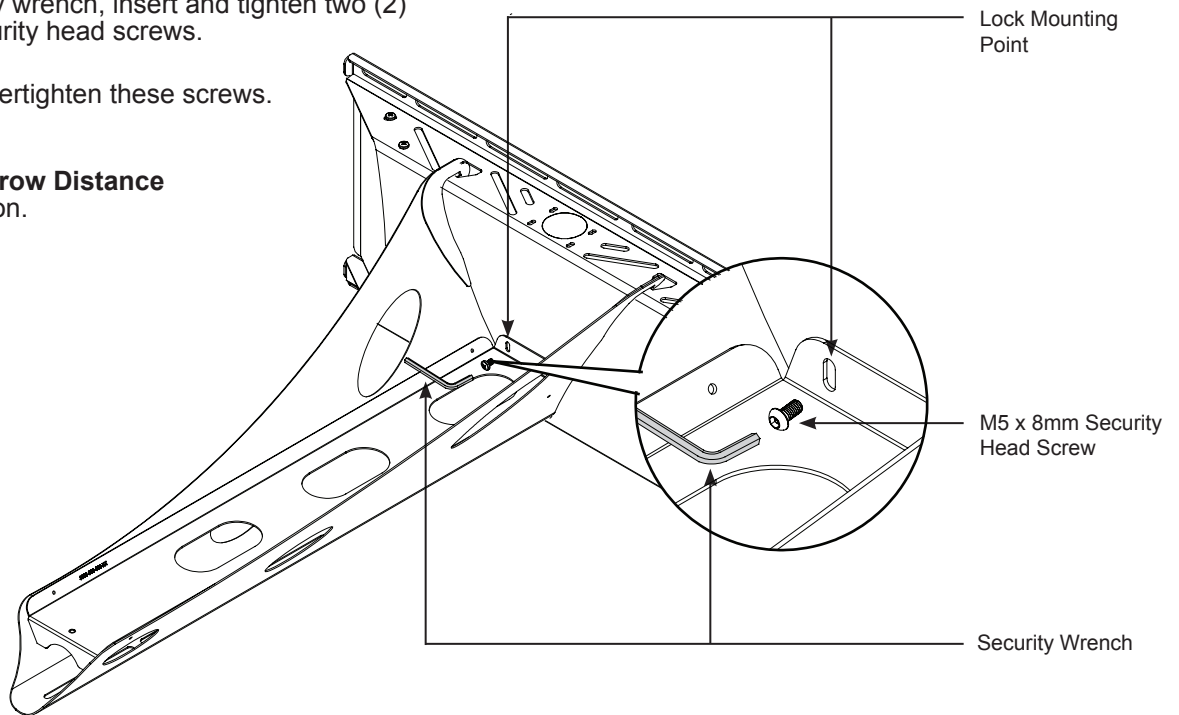
**Throw Distance Calculation**

Please review the Operator's Manual that came packaged with your projector before attaching the upper mounting bracket. The correct throw distance (the distance from the projector to the screen) must be determined prior to mounting the projector.

- 1 Refer to the projector's Users Manual to determine the distance from the lens to the front of the screen (X).
- 2 Measure the distance from the front of the lens to the center of the projector (Y).
- 3 Measure the distance from the wall to the face of the whiteboard/screen (Z).
- 4 Add all measurements (X + Y + Z) to determine projector placement on the arm assembly. This measurement will determine where the center of the mount bracket will be located on the arm assembly. Please make note of this measurement.

Calculations

X = Manufacturer's recommended throw distance

Z = Distance from wall to face of whiteboard/screen

Front Lens Throw Distance =  
(X + Y + Z)

Rear Lens Throw Distance =  
(X - Y + Z)

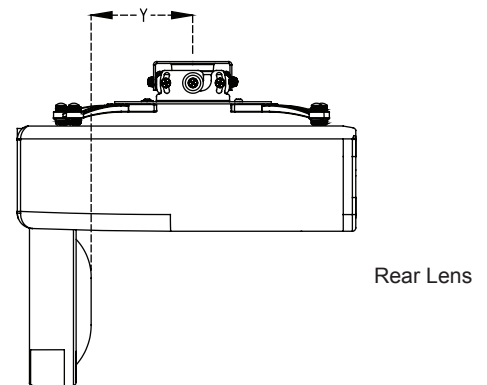
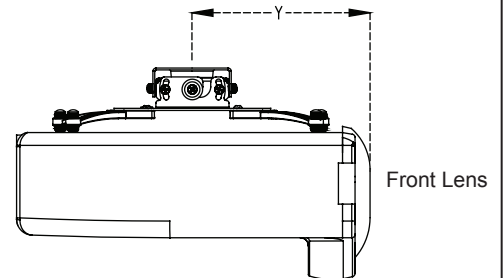

The UNI-STA/UNI-EXT can be also used as a wall-mounted standard projector mount as well as a short throw projector mount. Align the projector facing the opposite direction from the wall plate to project the image across the room. Please take into account the projector's throw capabilities prior to mounting in the projector opposite direction.

Proceed to the “**Adjustable Mounting Bracket Installation**” section.





## Adjustable Mounting Bracket Installation

- 1 Insert the inner slide plate into the projector arm.
- 2 Determine which adjustment slot best matches your throw distance calculation (above).
- 3 Raise the adjustable mounting bracket into position.
- 4 Align the mounting holes of the upper mounting plate with the mounting holes of the inner slide plate.



Two (2 - one per screw)  $\frac{1}{8}$ " nylon washers must be placed between the adjustable mounting bracket and the projector arm (see inset to the right).

- 5 Secure and finger-tighten two (2) M6 x 16mm security head screws.



If using the optional extension arm, proceed to Page 10.

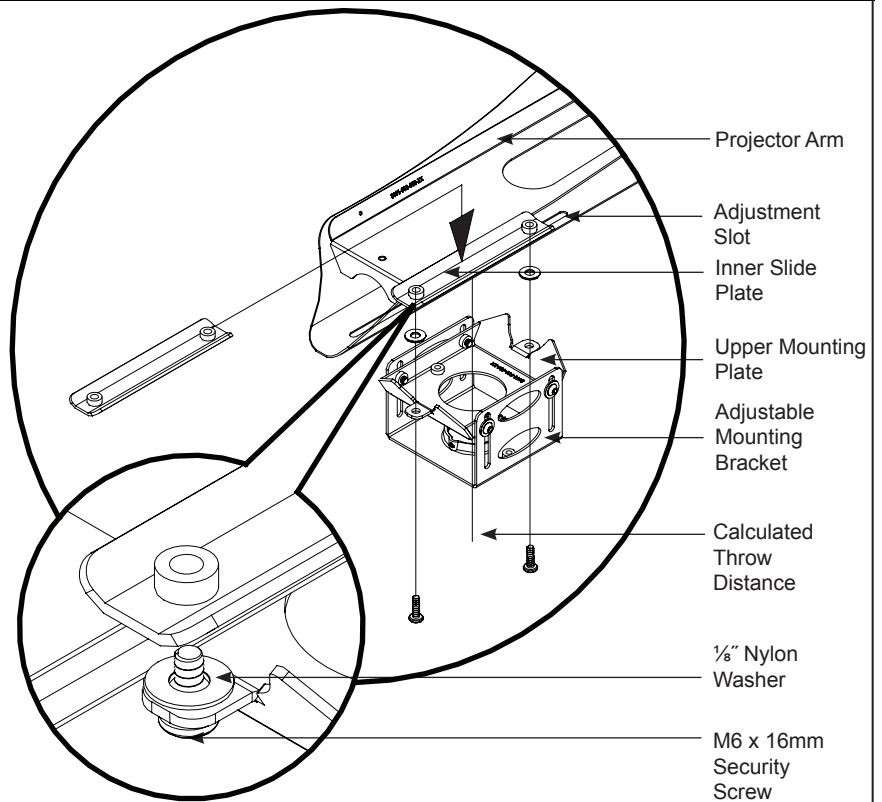

- 6 If needed, determine the Throw Distance again.
- 7 Once the correct throw distance has been determined, use the security wrench (supplied) to tighten the mounting screws.



If the adjustable mounting bracket needs to be adjusted, the four (4) M6 x 12mm security screws may be loosened so that the bracket can be moved  $\pm 2$ ". Once the desired height has been achieved, re-tighten the hardware.



Do NOT overtighten these screws.

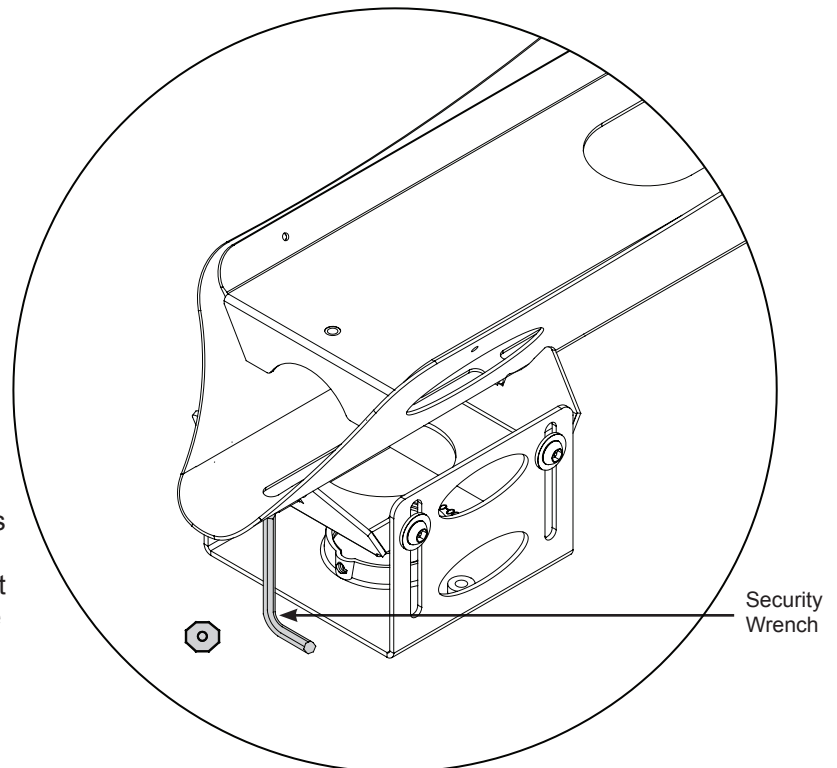

Proceed to the "Attaching the Base Box to the Adjustable Mounting Bracket" section.



## Attaching the Base Box to the Adjustable Mounting Bracket



The M6 x 12mm security head screws must be mounted from the underside of the base box.



Do NOT overtighten these screws.

- 1 Raise the base box to the upper mounting bracket.
- 2 Align the two (2; one each side) mounting holes.
- 3 Using a security wrench, insert and tighten two (2) M6 x 12mm security head screws.
- 4 Attach the projector to the base box, referring to the PDS-PLUS installation instructions for final adjustments.

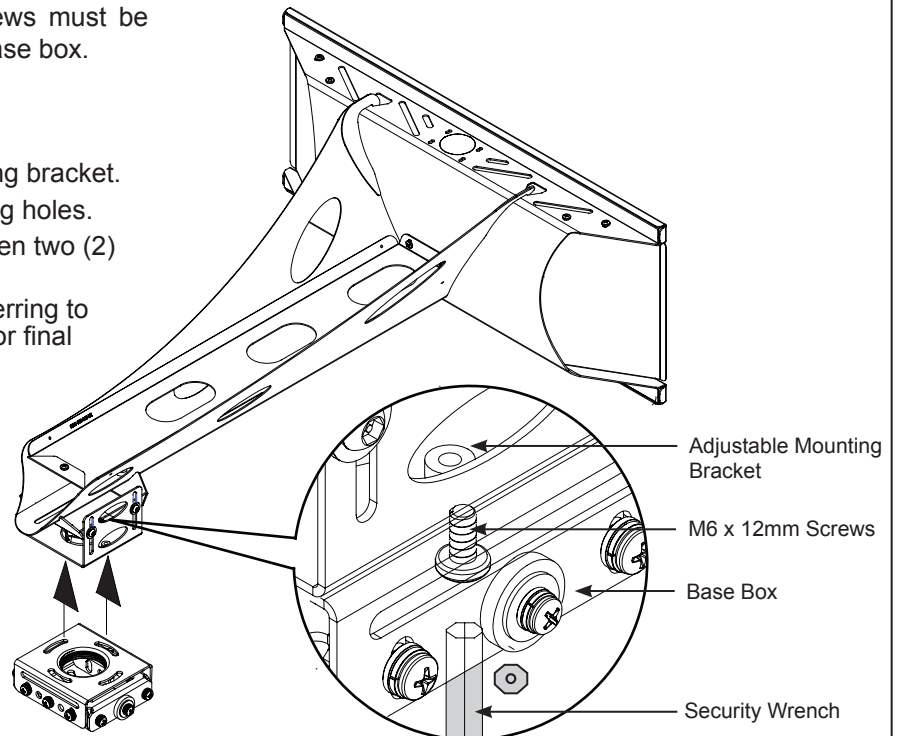

## Extension Arm Installation (Optional)



Please see the Operator's Manual to determine the correct throw distance (the distance from the projector to the screen). The throw distance must be determined prior to mounting the projector (Page 8).



If the extension arm is purchased at a later date, the end cover must be removed prior to installing the extension arm.

- 1 Slide the extension arm into the open end of the UNI-STA (the front of the mount).
- 2 Adjust length so that the center of the adjustable mounting bracket matches the throw distance calibration.
- 3 Line up the mounting holes on the extension arm with the mounting slots on the UNI-STA.
- 4 Using a screwdriver, insert and tighten two (2) M6 x 12mm security head screws and M6 flat washers through the external slide plate and tighten.
- 5 Attach the projector.



Please refer to **Attaching the Base Box to the Adjustable Mounting Bracket** (above) for steps on attaching the projector.

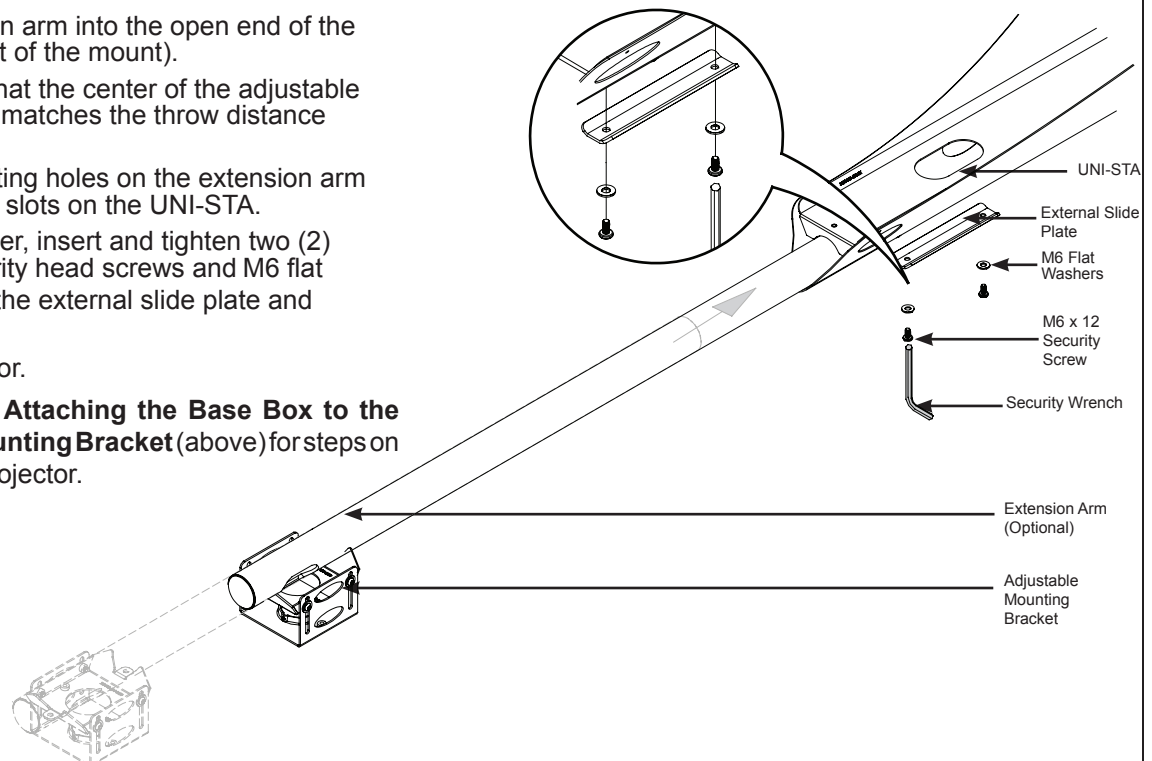

Proceed to the **"Low Profile Bracket Installation"** section.



## Low Profile Bracket Installation



Projector dimensions differ between manufacturers. If the projector hangs too low from the UNI-STA/UNI-EXT, the adjustable mounting bracket may be removed. This will allow you to attach the base box directly to the upper mounting bracket for an even lower profile installation.

- ❶ Using a M5 security wrench, remove the four (4) M6 x 12mm security screws by rotating the security wrench counterclockwise.
- ❷ Slide the adjustable mounting bracket off the upper mounting bracket.

Proceed to the “**Attaching the Base Box to the Upper Mounting Plate**” section.

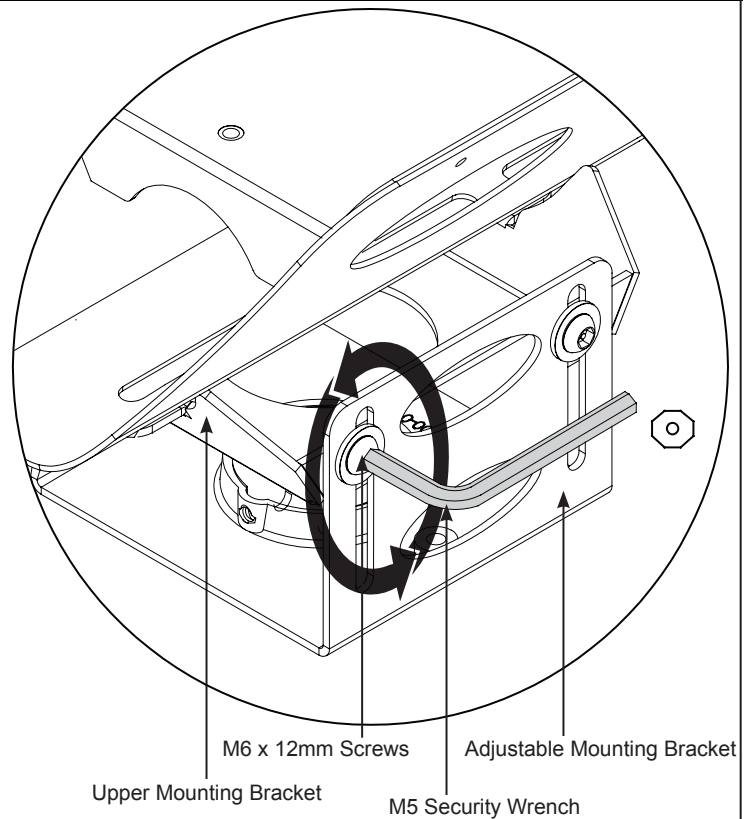

## Attaching the Base Box to the Upper Mounting Plate



The PDS-PLUS comes with optional security hardware (Lock-It™ Security Pack) that may be installed for added security.



Please review the installation instructions that came packaged with the projector before attaching the projector to the upper mounting bracket.



The M6 x 12mm security head screws must be mounted from the underside of the base box.



Do not overtighten the screws.

- ❶ Raise the base box to the upper mounting bracket.
- ❷ Align the two (2; one each side) mounting holes.
- ❸ Using a security wrench, insert and tighten two (2) M6 x 12mm security head screws.
- ❹ Attach the projector to the base box, referring to the PDS-PLUS installation instructions for final adjustments.

Proceed to the “**Attaching the Universal Projector Plate**” section.

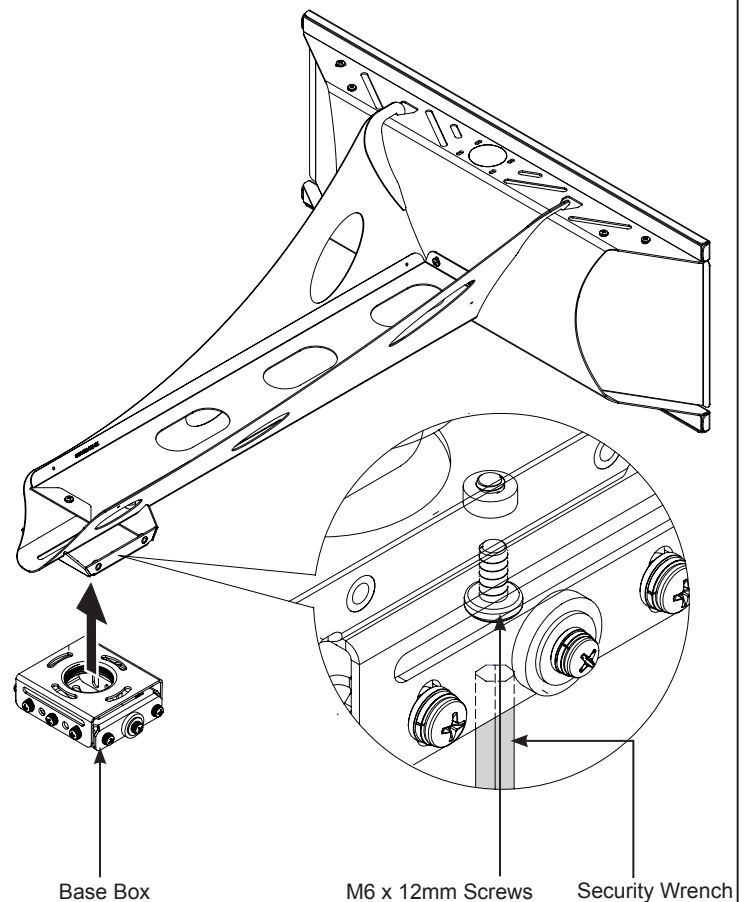



# Attaching the Universal Projector Plate

## Selecting the Mounting Hardware

- 1 Insert a small straw or toothpick into the threaded inserts found on the bottom or top of the projector.
- 2 Use a pencil to mark the depth of the threaded insert on the small straw or toothpick.
- 3 Mark the straw or toothpick 1/8" above the depth of the threaded insert, as shown in Figure 1.
- 4 Insert the small straw or toothpick into the remaining threaded inserts to compare and verify their depth using the straw or toothpick's 1/8" allowance mark.
- 5 Locate the correct diameter screw for the threaded insert.

 If the screw you selected is longer than the 1/8" allowance mark on the small straw or toothpick, as shown in Figure 2 and Figure 3, do not use this screw. The screw length must not bypass the mark.

- 6 Test each size of the screws provided.

The correct screws should thread easily into the mounting point and not pull out when tension is applied.

 Does your projector have multiple mount points or a single mount point?

If your projector has multiple mount points, proceed to the **"Multiple Mount Point Installation"** section.

If your projector has a single mount point, skip to the **"Single Mount Point Installation"** section.

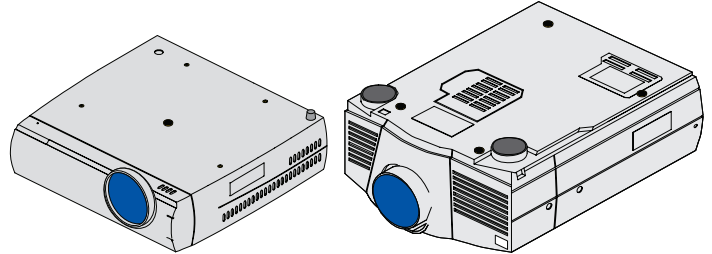
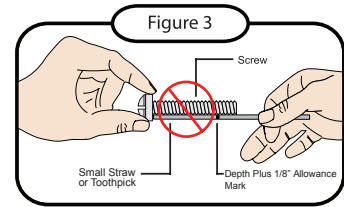
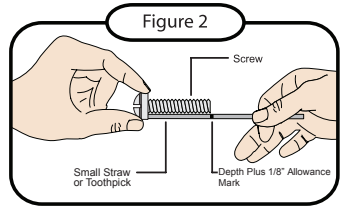
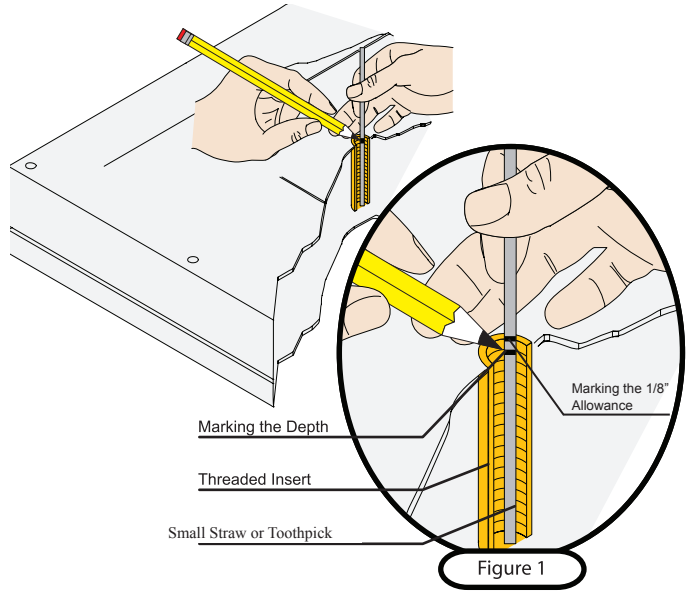



## Attaching the Universal Projector Plate (cont'd)

### Multiple Mount Point Installation

#### Step 1

- 1 Locate the projector's mount points.
- 2 Position an appropriate number of mounting legs on the projector.

You can use any combination of three (3) or more long mounting legs and short mounting legs, depending on the number and location of the thread inserts on your projector.



The number and placement of mount points on projectors varies between projector manufacturers. This example projector has five (5) mount points, but only uses four (4) mounting legs.

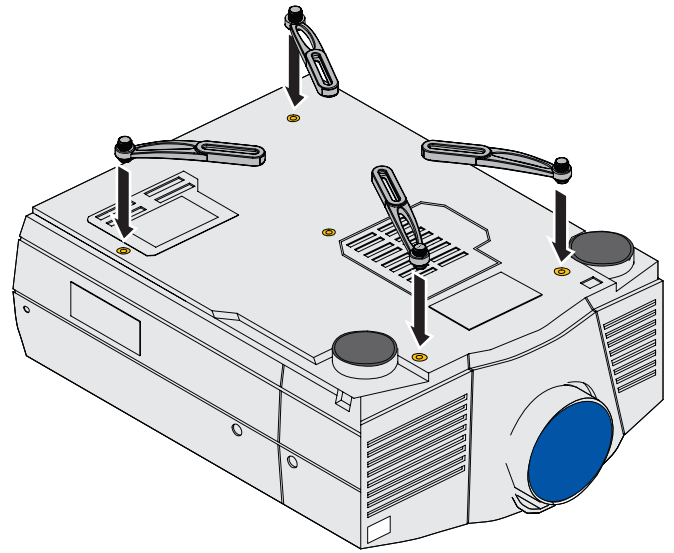

#### Step 2

Insert the mounting hardware, as determined in the “**Selecting the Mounting Hardware**” section, through the leveling barrel into the thread insert of the projector.



You can use either the standard Phillips head or Lock-It™ security hardware.

Do not tighten the mounting hardware at this time.

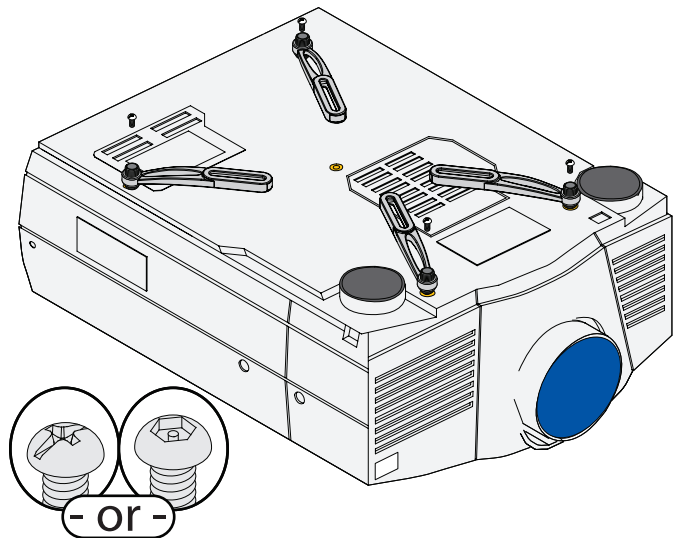

#### Pro Tip



##### Mounting Hardware Too Long?

The depth of some projector mount points may prevent you from tightening the M2.5 and M3 mounting hardware.

You can reduce the length of the M2.5 and M3 mounting hardware by stacking up to a maximum of five (5) M3 flat washers inside the leveling barrel.



Avoid stacking too many M3 washers; the mounting hardware must thread into the projector mount point at least four (4) complete turns.

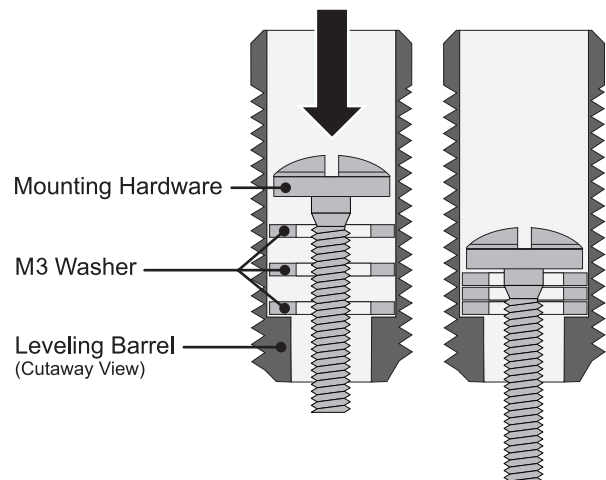



## Attaching the Universal Projector Plate (cont'd)

### Step 3

Raise or lower each of the mounting legs, by rotating the leveling barrels, until all of the mounting legs are at an equal height.

- Lower the mounting leg by rotating the leveling barrel counter-clockwise.
- Raise the mounting legs by rotating the leveling barrel clockwise.

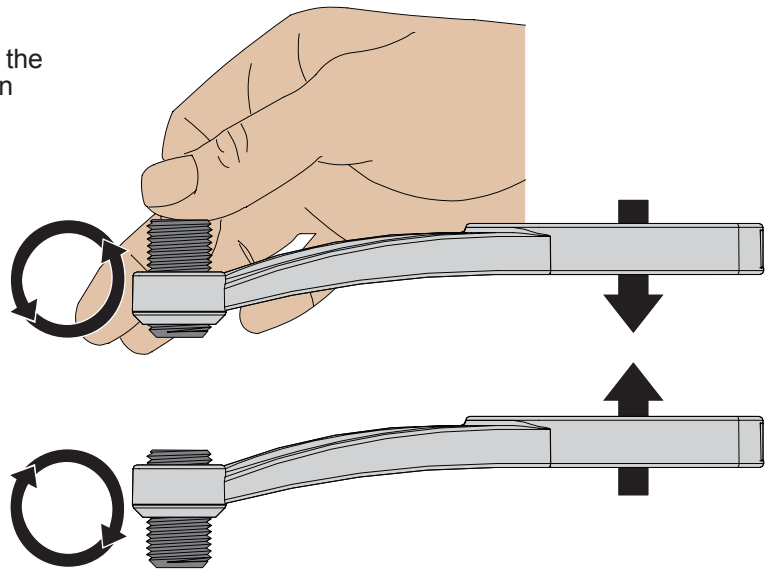

### Step 4

- 1 Identify the projector's approximate front-to-back center of gravity. Place your hands on each side of the projector and gently lift it an inch from the surface on which it is resting. Carefully adjust your grip on the projector until it seems balanced from front-to-back. Mentally note the apparent center of gravity.
- 2 Identify the projector's approximate side-to-side center of gravity. Place your hands on the front and back of the projector and gently lift it an inch from the surface on which it is resting. Carefully adjust your grip on the projector until it seems balanced from side-to-side. Mentally note the apparent center of gravity.
- 3 Place the Universal Projector Plate on top of the mounting legs with the center hole as close as possible to the projector's center of gravity.

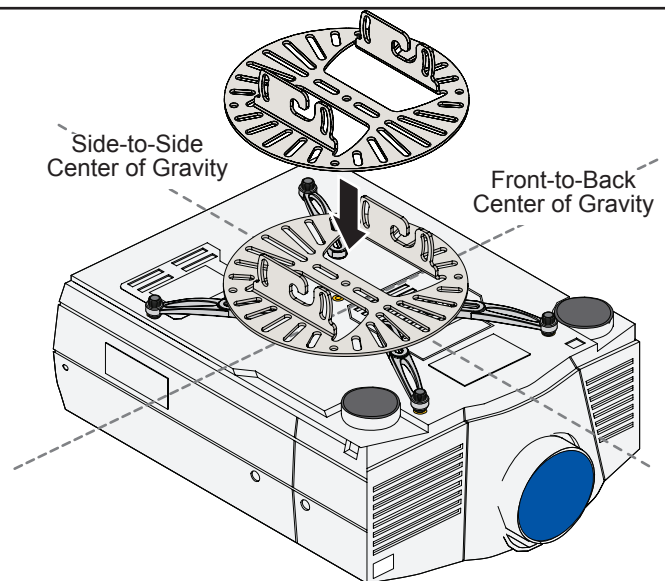

### Step 5

- 1 Verify that the mounting legs are at an equal height. Return to **Step 3** if they are not at an equal height or the Universal Projector Plate is not level.
- 2 Verify the position of the integrated sliding M6 square nut in the mounting leg relative to a nearby slot on the Universal Projector Plate.
  -  If the M6 square nut is not aligned with any slot, you can use any thin implement, such as a toothpick, to nudge it into alignment.

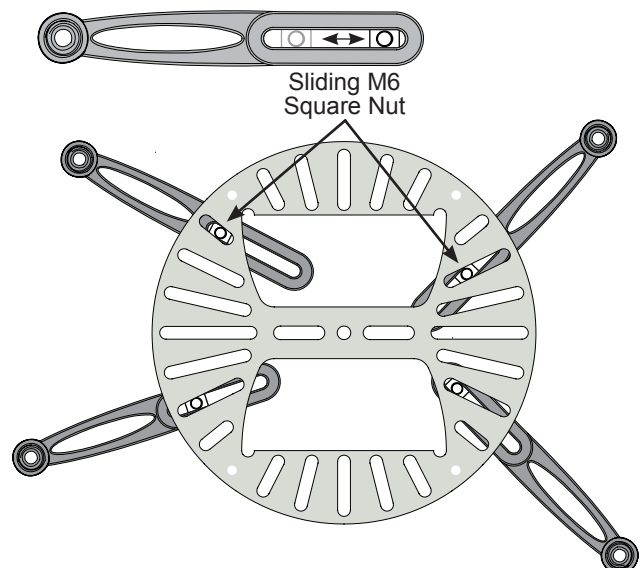



## Attaching the Universal Projector Plate (cont'd)

### Step 6

Tighten the mounting screws to the projector.

 Do not overtighten the mounting screws.

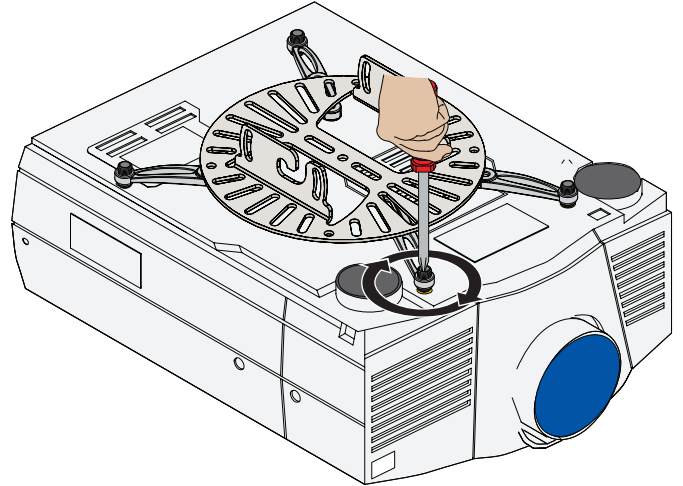

### Step 7

- 1 Attach the Universal Projector Plate to each of the mounting legs by inserting and tightening one (1) M6 x 12mm screw through the Universal Projector Plate into the M6 square nut on each of the mounting legs.

 Do not overtighten the mounting screws.

 You can use either the standard Phillips head or Lock-It™ security hardware.

- 2 Insert one (1) Barrel Cap into the end of each leveling barrel.

Proceed to the “**Single Mount Point Installation**” section.

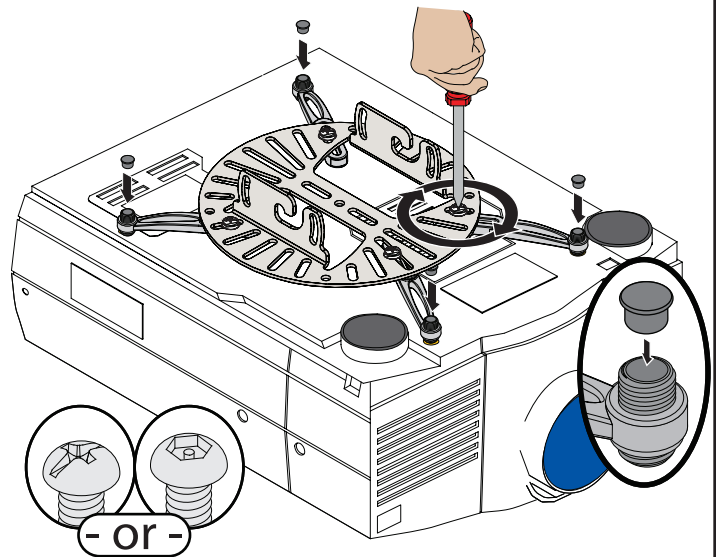

### Single Mount Point Installation

A single 1/4-20 x 5/16" screw must be used to attach the Universal Projector Plate to the projector if your projector has only one mounting point.

 Do not overtighten the mounting screws.

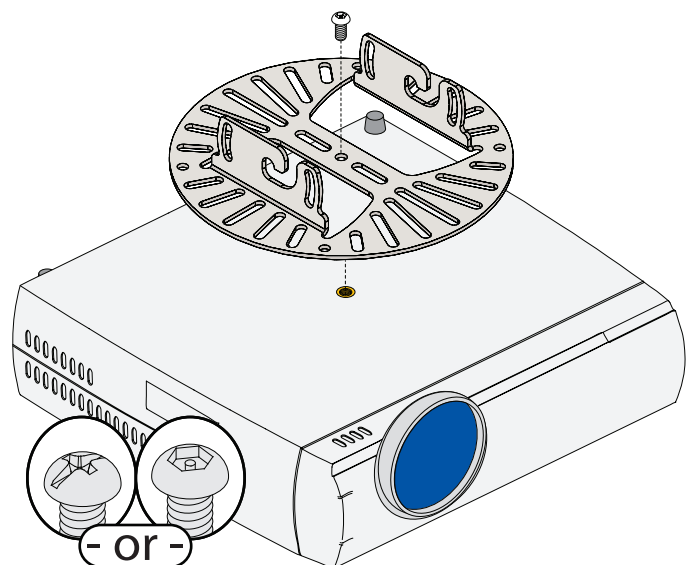

 You can use either the standard Phillips head or Lock-It™ security hardware.

Proceed to the “**Attaching the Projector**” section.





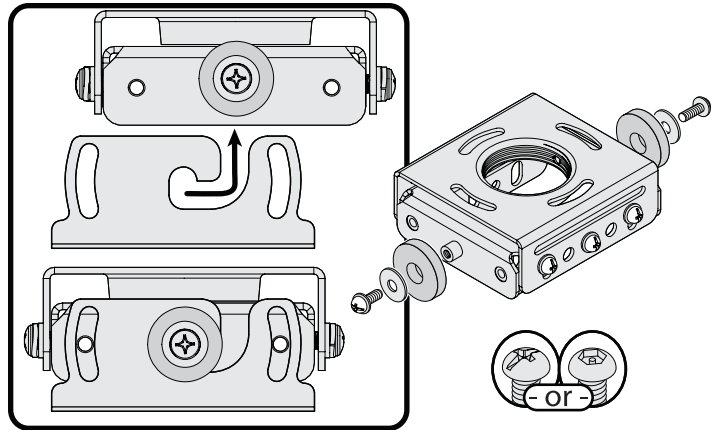

## Attaching the Projector

- ❶ Place one (1) nylon washer and one (1) ¼" flat washer over the hinge pin.
  - ❷ Insert and tighten one (1) M6 x 12mm screw.
  - ❸ Repeat ❶ and ❷ for the opposite hinge pin.
-  You can use either the standard hardware or Lock-It™ security hardware. Replace eight (8) M6 x 12mm screws and one (1) M6 x 8mm set screw.
-  Do not overtighten the M6 x 12mm screws or the M6 x 8mm set screw.
- ❹ Slide the projector / Projector Plate assembly onto the PDS Base Box.
  - ❺ Hook the Projector Plate over the hinge pins, as shown.



- ❻ Insert the four (4) M6 x 12mm tilt adjustment screws, two (2) per side.
-  You can use either the standard hardware or Lock-It™ security hardware.
- ❼ Tighten all screws.
-  Do not overtighten the mounting screws.
- ❽ Follow the PDS Installation Instructions to complete the installation.

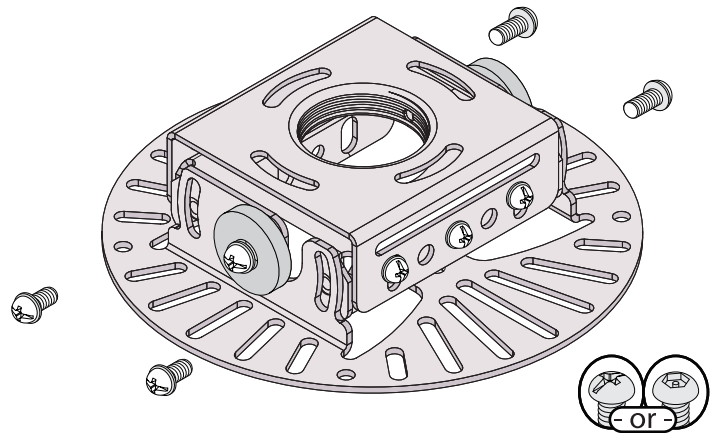





## Set Screw Installation



The security set screw will prevent the unit from being removed and from being knocked out of adjustment.

The M6 set screw will be used in conjunction with any standard threaded adapter (sold separately).

- ❶ Thread in threaded adapter until securely fastened.
- ❷ Thread in one (1) M6 x 6mm set screw.
- ❸ Use an M3 security wrench to tighten the M6 set screw (included in the PDS-PLUS hardware).

Proceed to the “**Utilizing the Storage Feature**” section.

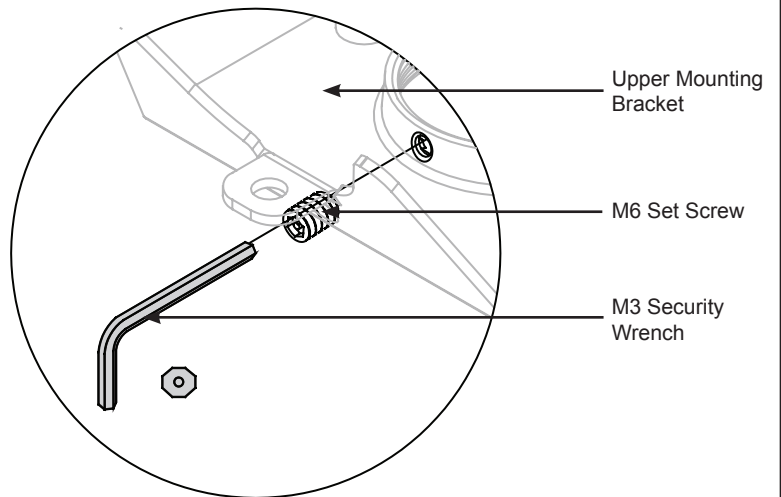

## Utilizing the Storage Feature

The storage feature may be used to store electronic components. There is an accessible door on each side of the storage enclosure. It may be securely held shut with the use of four (4) M5 x 8mm security head screws. It may be easiest to pre-wire all cables down the arm (or extension) at this time.

- ❶ Open the storage door that is located on the side of the wall plate.
- ❷ Place the electronic components inside the storage enclosure.
- ❸ Make all electronic connections at this time.
- ❹ Close the storage door and secure using two (2; 1 upper and 1 lower) M5 x 8mm security head screws. Tighten using a security wrench. Repeat this process for the other side as well.

Proceed to the “**Cable Management**” section.

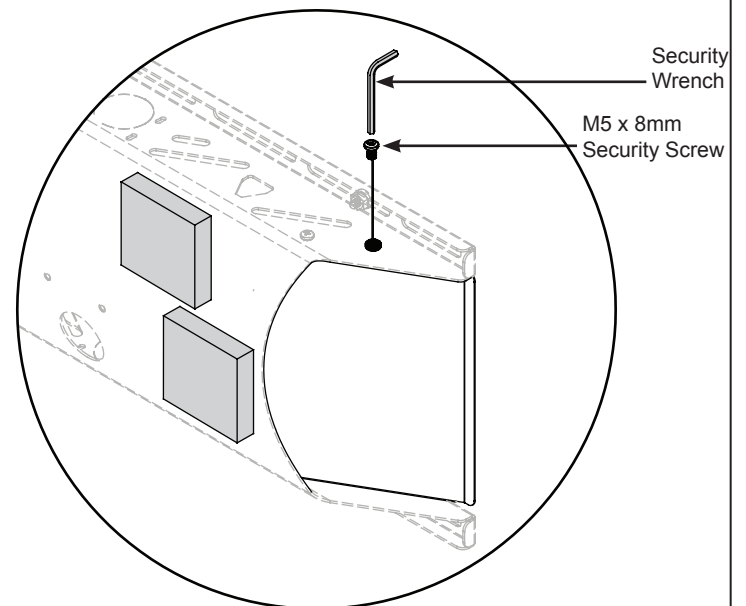
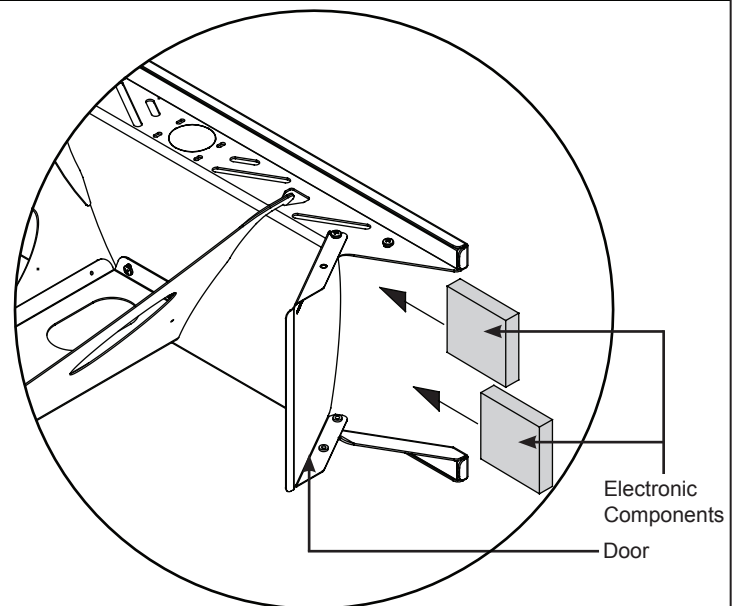



### Cable Management

- 1 The cable access holes are located at the end of the short throw mount and on the wall plate.
- 2 Route the cables through one end of the UNI-STA/UNI-EXT and out the other end.
- 3 Attach the end cover with an M5 x 8mm security head screw.



You may direct the cables out the end of the UNI-STA/UNI-EXT. The end cover has a perforated tab to allow cables to pass out the end. Pliers must be used to bend the perforated tab. If the cables will not fit, the end cover may be removed by loosening and extracting the M5 x 8mm security screw.

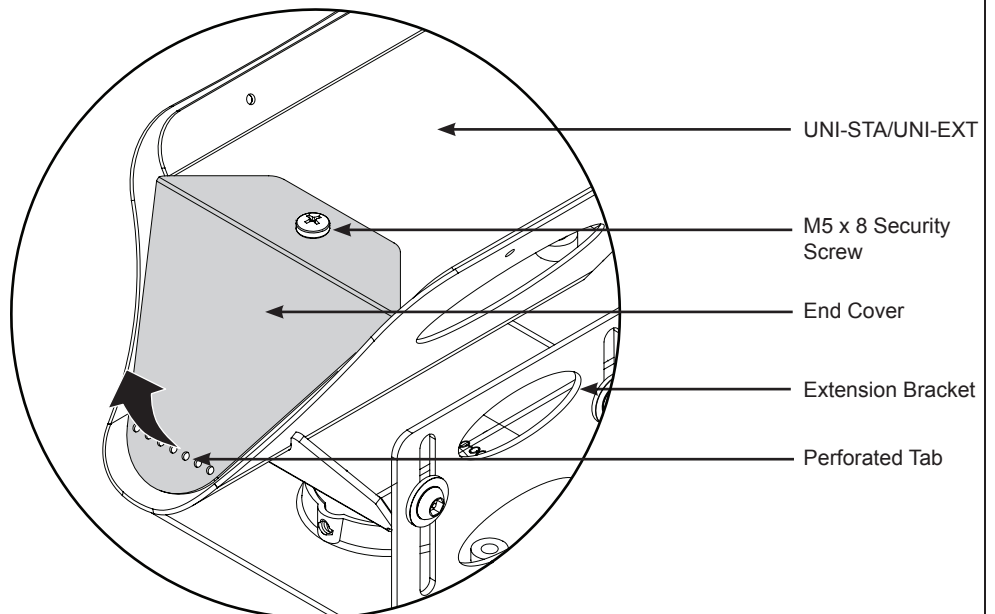
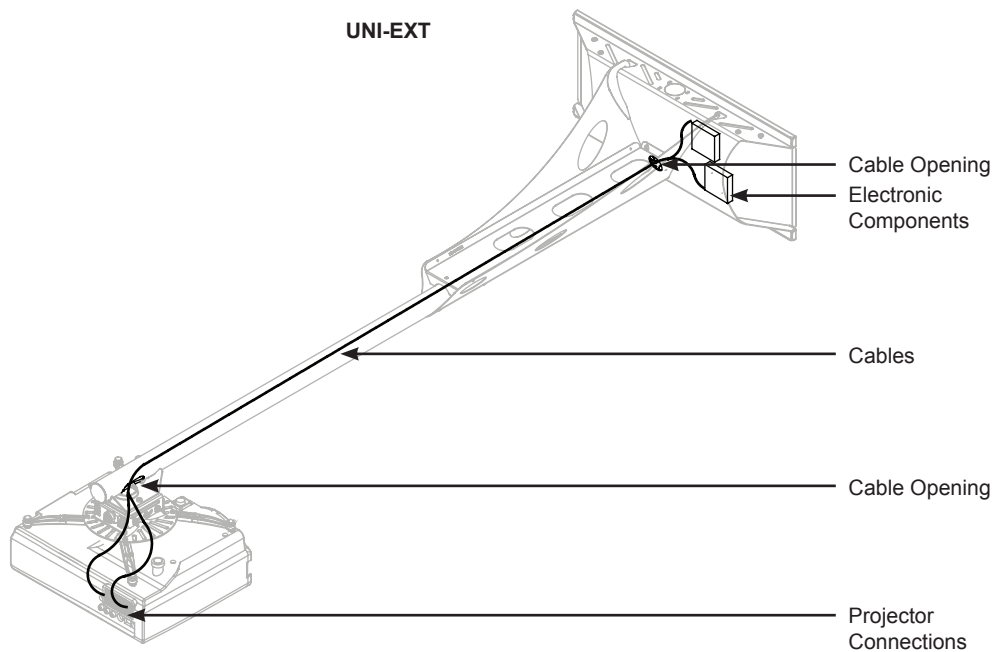
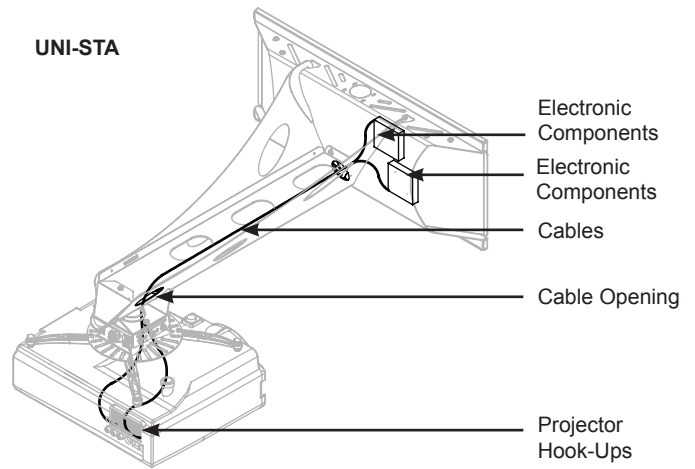



# Technical Specifications

All measurements are in inches(mm).

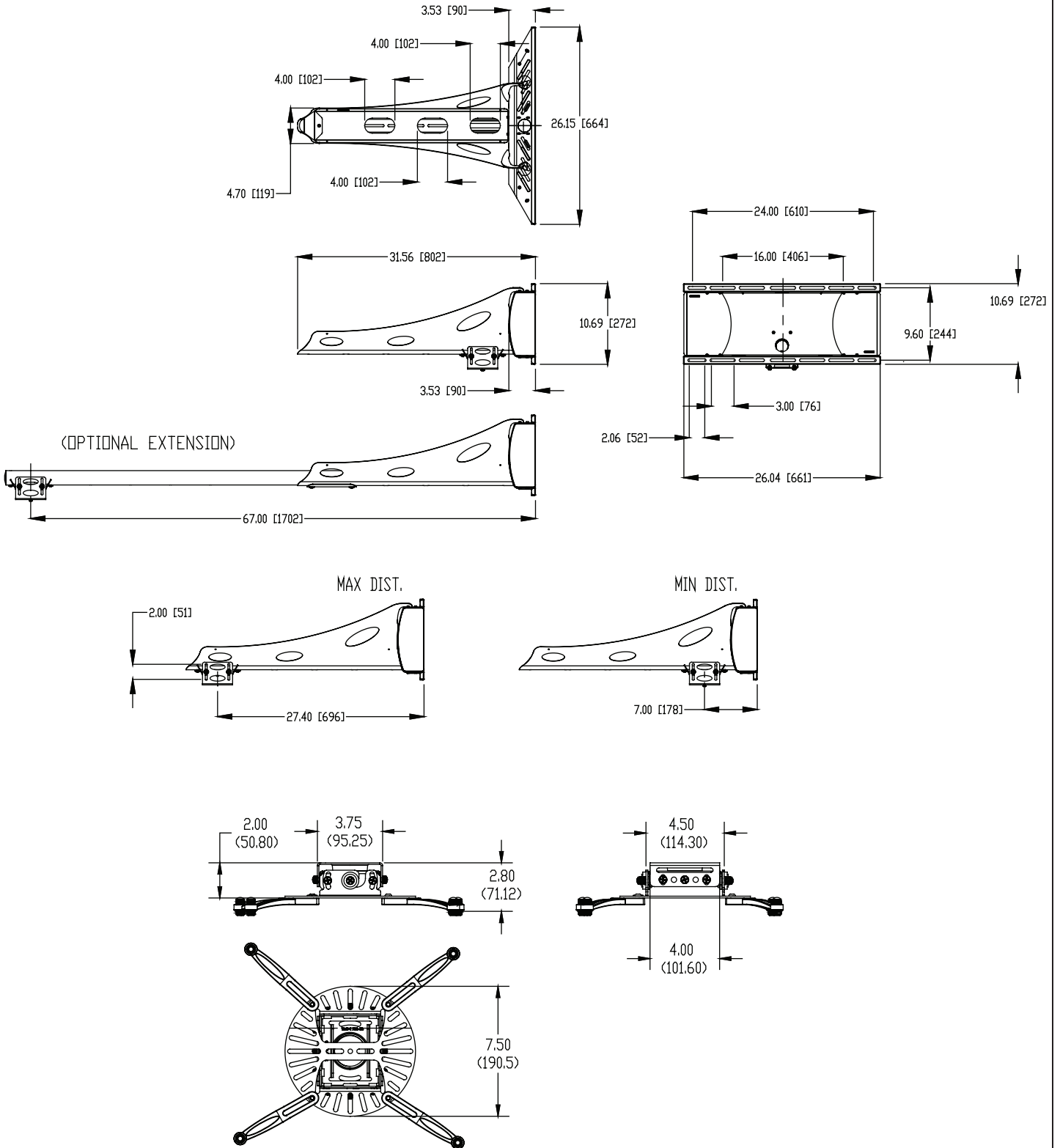



## Warranty

### PREMIER MOUNTS LIMITED LIFETIME WARRANTY

#### What and Who is Covered by this Limited Warranty and for How Long

Premier Mounts warrants this product to be free from defects in material and workmanship for the lifetime of the original owner of this product. The limited warranty is valid only for the original purchaser of the product.

#### What Premier Mounts Will Do

At the sole option of Premier Mounts, Premier Mounts will repair or replace any product or product part that is defective. If Premier Mounts chooses to replace a defective product or part, a replacement product or part will be shipped to you at no charge, but you must pay any labor costs.

#### What is Not Covered; Limitations

PREMIER MOUNTS DISCLAIMS ANY LIABILITY FOR DAMAGE TO MOUNTS, ADAPTERS, DISPLAYS, PROJECTORS, OTHER PROPERTY, OR PERSONAL INJURY RESULTING, IN WHOLE OR IN PART, FROM IMPROPER INSTALLATION, MODIFICATION, USE OR MISUSE OF ITS PRODUCTS.

PREMIER MOUNTS DISCLAIMS ALL OTHER WARRANTIES, EXPRESS OR IMPLIED, INCLUDING WARRANTIES OF MERCHANTABILITY AND FITNESS FOR A PARTICULAR PURPOSE. PREMIER MOUNTS IS NOT RESPONSIBLE FOR INCIDENTAL OR CONSEQUENTIAL DAMAGES, INCLUDING BUT NOT LIMITED TO, INABILITY TO USE ITS PRODUCTS OR LABOR COSTS FOR REMOVING AND REPLACING DEFECTIVE PRODUCTS OR PARTS. SOME STATES DO NOT ALLOW THE EXCLUSION OR LIMITATION OF INCIDENTAL OR CONSEQUENTIAL DAMAGES, SO THE ABOVE LIMITATION OR EXCLUSION MAY NOT APPLY TO YOU.

#### What Customers Must Do for Limited Warranty Service

If you discover a problem that you think may be covered by the warranty you MUST REPORT it in writing to the address below within thirty (30) days. Proof of purchase (an original sales receipt) from the original consumer purchaser must accompany all warranty claims. Warranty claims must also include a description of the problem, the purchaser's name, address, and telephone number. General inquiries can be addressed to Premier Mounts Customer Service at 1-800-368-9700. Warranty claims will not be accepted over the phone or by fax.

Premier Mounts  
Attn: Warranty Claim  
3130 East Miraloma Ave.  
Anaheim, CA 92806

#### How State Law Applies

THIS WARRANTY GIVES YOU SPECIFIC LEGAL RIGHTS, AND YOU MAY ALSO HAVE OTHER RIGHTS WHICH VARY FROM STATE TO STATE.

## Disclaimer

Premier Mounts intends to make this manual accurate and complete. However, Premier Mounts makes no claim that the information contained herein covers all details, conditions or variations, nor does it provide for every possible contingency in connection with the installation or use of this product. The information contained in this document is subject to change without notice or obligation of any kind. Premier Mounts makes no representation of warranty, expressed or implied, regarding the information contained herein. Premier Mounts assumes no responsibility for accuracy, completeness or sufficiency of the information contained in this document.