

DS-VW660

Video Wall Mounting Solution

For 40" to 65" displays

The Peerless DS-VW660 mount is the latest flat wall mounting solution for easily and quickly installing either small or large video wall configurations. In contrast to standard video wall installations, the DS-VW660 mount includes innovative features that simplify the full installation process, reducing gaps between display units and minimizing tedious calculations and guesswork. The DS-VW660 is engineered to support a wide variety of display configurations while ensuring each mount is positioned for the specific display being used, which reduces on-site measuring and guesswork by utilizing custom-fit wall plate alignment spacers. Display alignment is made easy with four points of tool-less adjustment on each DS-VW660 model – ensuring each display will be level in its environment.



TV size: 40"-65"



Max load: 200lb (90.9kg)

FEATURES

- Modular mount for unlimited video wall display configurations
- Custom wall plate spacers eliminate guesswork and on-site installation calculations
- Tool-less micro-adjustments at 4 points seamlessly align the displays
- Displays and mounts sit flush against the wall for a clean profile
- Snug fit at the attachment point to the display's mounting hole pattern ensures that each display hung in succession is aligned at the same point
- Integrated cable management tie-backs make display-to-display cabling simple
- Landscape display orientation
- Adjustable VESA® mounting hole patterns in 100mm increments, starting at 200x200mm up to 600x400mm, additional patterns supported with adapter plates
- Includes hardware for installation to wood, concrete or cinder block
- Supports displays up to 200lb (90.9kg)

NO CALCULATIONS, NO GUESSWORK

Custom wall plate spacers eliminate the guesswork and on-site installation calculations



INCREASED ELECTRICAL AND CABLE MANAGEMENT OPTIONS

Total wall access is achieved with a unique open wall plate design allowing for increased easy routing of cables and placement of electrical conduits

EASY BY-HAND PRECISION DISPLAY ALIGNMENT

Tool-less micro-adjustments at 4 points seamlessly align the displays

SIMPLIFIED DISPLAY-TO-DISPLAY CABLING

Integrated cable tiebacks ensure easy and organized cabling between displays



Modular Design



Wall Plate Spacers (sold separately)



Four-point adjustment knobs

Patent Pending



CLICK: www.peerlessmounts.com

CALL: 800.865.2112

FAX: 708.865.2941

peerless®

DS-VW660 Video Wall Mounting Solution for 40" to 65" displays

Product Specifications

| | DIMENSIONS (W x H x D) | PRODUCT WEIGHT | LOAD CAPACITY | FINISH | AVAILABLE COLORS |
|-----------------|--|----------------|----------------|-------------------------------|------------------|
| DS-VW660 | 35" x 20" x 3.0" (889 x 508 x 76.2mm) | 36lb (15.9kg) | 200lb (90.9kg) | Scratch resistant fused epoxy | Black |

Package Specifications

| | PACKAGE SIZE (L x W x H) | PACKAGE SHIP WEIGHT | PACKAGE UPC CODE | PACKAGE CONTENTS | UNITS IN PACKAGE |
|-----------------|---|---------------------|------------------|--|------------------|
| DS-VW660 | 38" x 24" x 5" (965.2 x 609.6 x 127mm) | 43lb (19.5kg) | 735029272052 | Wall plate, wall mount assembly, mounting attachment rails, security hardware, fastener pack | 1 |

Patent Pending

Accessories

DS-VWS###: Wall Plate Alignment Spacers*
 *Contact your Peerless Customer Care Representative for display-specific models

Works with all Peerless PLP-style VESA® mounting hole adapter plates

All dimensions = inch (mm)

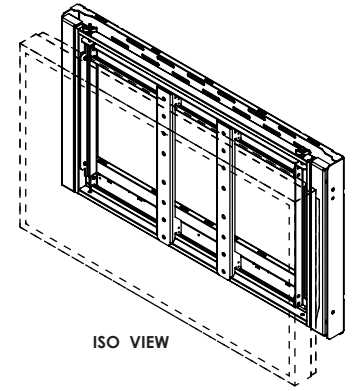
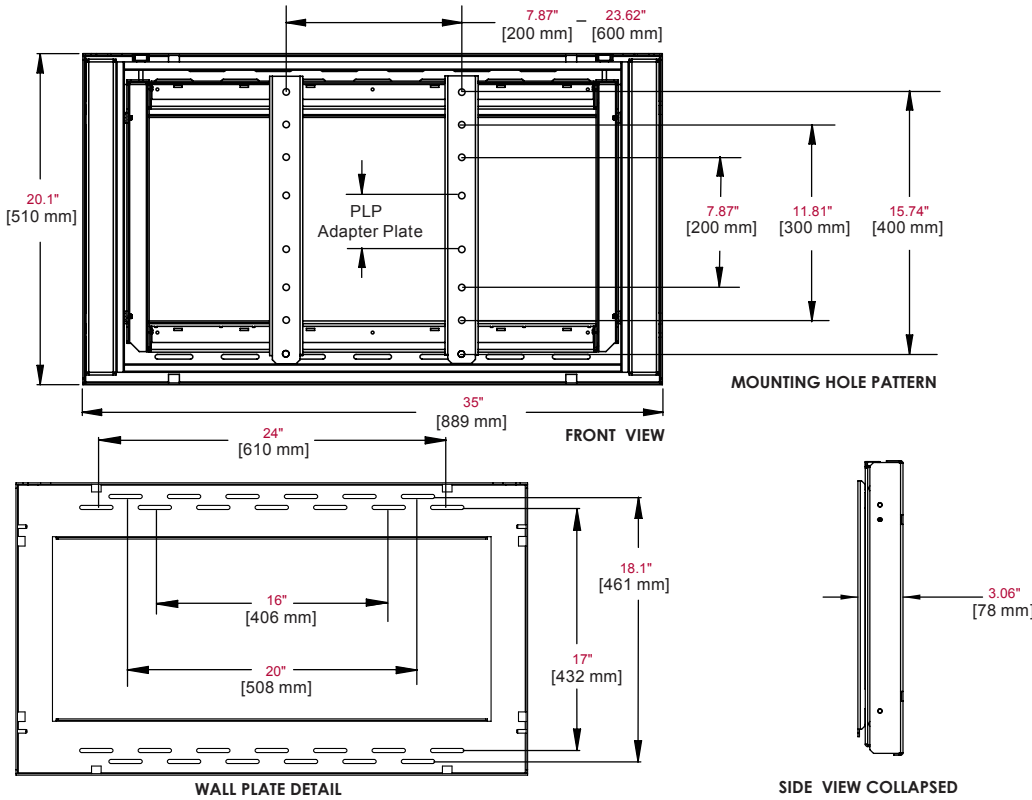

ARCHITECTS SPECIFICATIONS

The pull-out video wall mount shall be Peerless model DS-VW660 and shall be located where indicated on the plans. It shall be constructed of heavy gauge steel. The finish shall be scratch resistant black fused epoxy. Assembly and installation shall be done according to instructions provided by the manufacturer.