

DS-VW646-2X2

Universal 2x2 Video Wall Mounting Kit For 40" to 46" Flat Panel Displays*

* Please check compatibility formula with your display dimensions.

Creating a 2x2 video wall is simple and cost effective with the Peerless-AV DS-VW646-2X2 video wall kit. The single wall frame design is quickly installed and then you're ready to start hanging displays. Built in horizontal adjustment makes aligning displays easy. Due to the thin design, ADA compliance is a non issue with displays measuring 1.71" deep or less.



FEATURES

- 2x2 video wall mounting kit
- Horizontal adjustment makes mounting and aligning displays quick and easy
- Compatible with most displays 40"-46"
- Included security screws deter tampering and theft
- ADA compliant with displays measuring 1.71" deep or less
- Includes adapter rail alignment measuring plate to assist in the mounting of the displays
- Fully VESA® compliant



Display size: 40"-46"



Max load: 600lb (272kg)

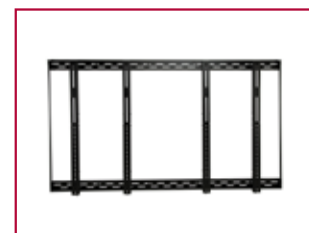
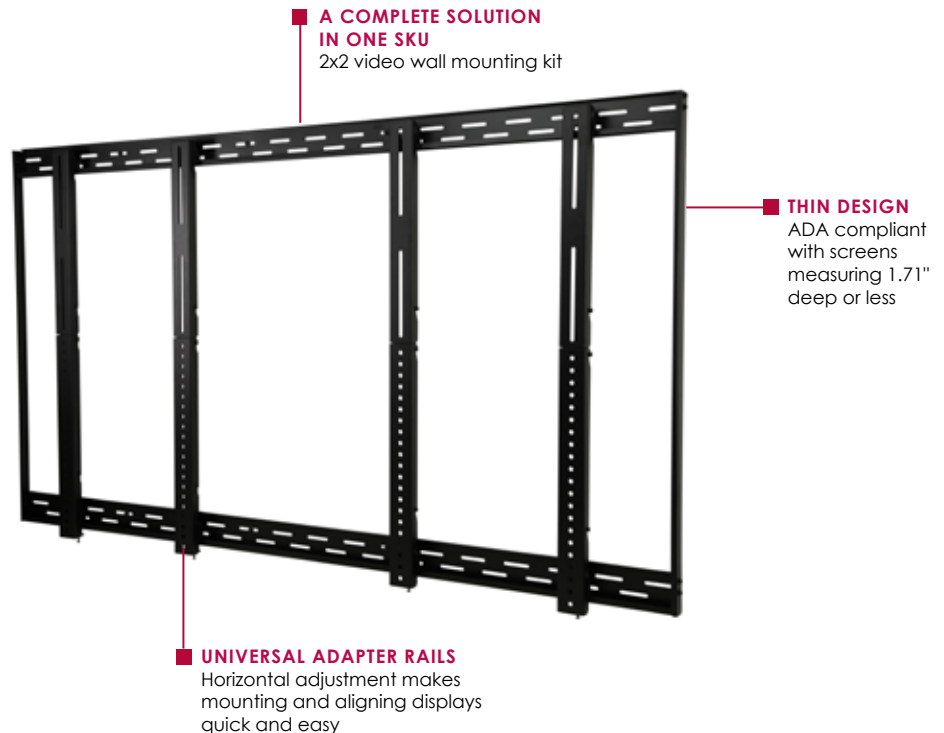

2x2 Mounting Kit



Profile with display
attached



DS-VW646-2X2 Universal 2x2 Video Wall Mounting Kit for 40" to 46" Flat Panel Displays*

* Please check compatibility formula with your display dimensions.

Product Specifications

	DIMENSIONS (W x H x D)	PRODUCT WEIGHT	LOAD CAPACITY	FINISH	AVAILABLE COLORS
DS-VW646-2X2	71.54" x 41.04" x 2.29" (1817 x 1042 x 58mm)	55lb (25kg)	600lb (272kg)	Powder Coat	Black

Package Specifications

	PACKAGE SIZE (L x W x H)	PACKAGE SHIP WEIGHT	PACKAGE UPC CODE	PACKAGE CONTENTS	UNITS IN PACKAGE
DS-VW646-2X2	Box 1: 72" x 4" x 4" (1829 x 102 x 102mm) Box 2: 45.75" x 17.125" x 4.25" (1162 x 435 x 108mm)	63lb (28.6kg)	735029281924	Wall frame, adapter rails, measuring plate and mounting hardware	1

All dimensions = inch (mm)

COMPATIBILITY FORMULA
 Display must be at least 36" wide and 20.75" high
 Width of the display + width of the mounting hole pattern < 1733 mm
 Height of the display + height of the mounting hole pattern < 1136 mm

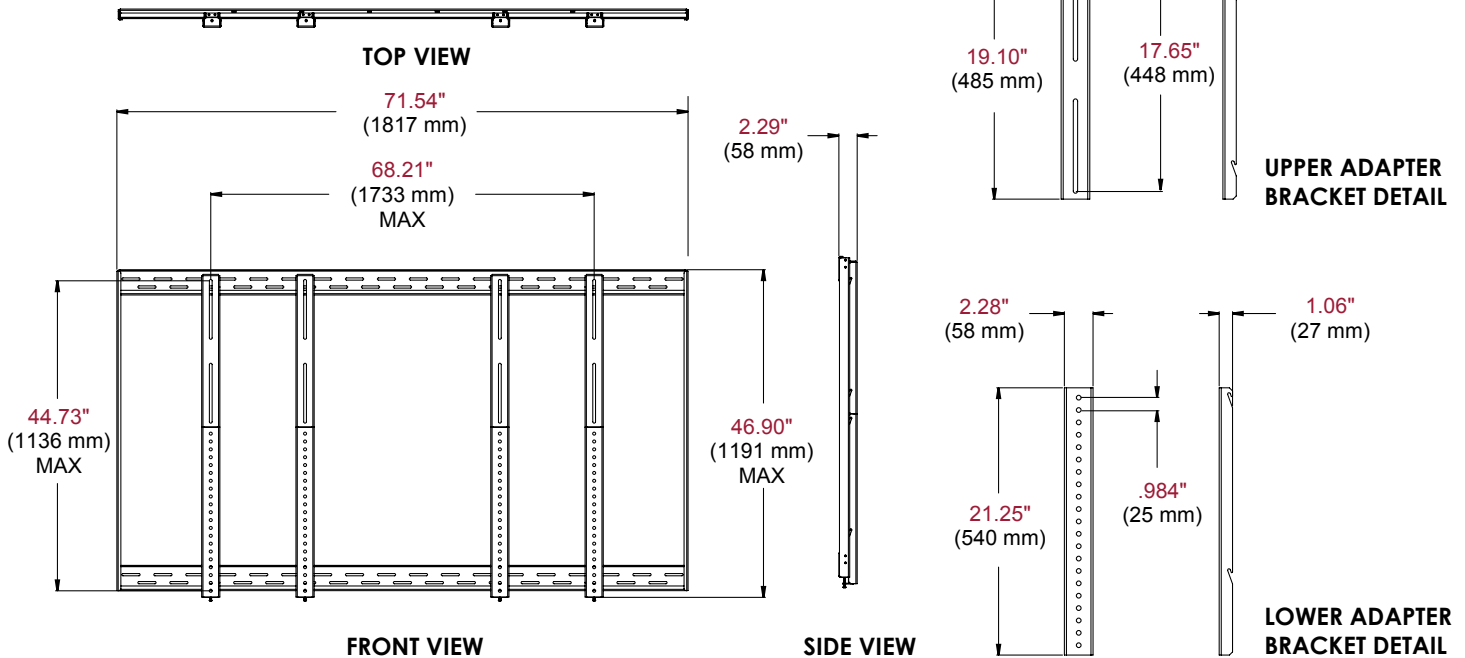

ARCHITECTS SPECIFICATIONS

The Universal 2x2 Video Wall Mounting Kit shall be Peerless-AV model DS-VW646-2X2 and shall be located where indicated on the plans. It shall be constructed of heavy gauge steel. The finish shall be scratch resistant black fused epoxy. Assembly and installation shall be done according to instructions provided by the manufacturer.

Peerless Industries, Inc. ■ 2300 White Oak Circle ■ Aurora, IL 60502 ■ (800) 865-2112 ■ (630) 375-5100 ■ Fax: (800) 359-6500 ■ www.peerless-av.com

Visit www.peerless-av.com to see the complete line of AV solutions from Peerless-AV, including flat panel mounts, projector mounts, carts/stands, furniture, cables, screen cleaners and a full assortment of accessories.