

Mobile Video Wall Cart Installation

MVWS-2X2-4655 MVWS-3X3-55

MVWS-3X3-55

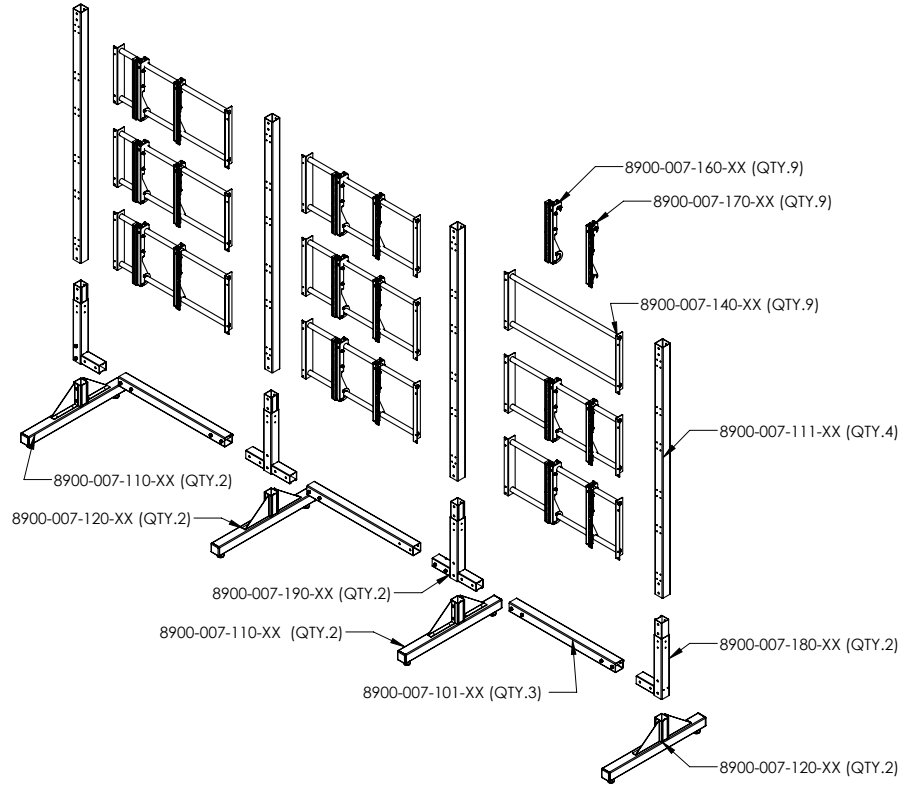

MVWS-2X2-4655

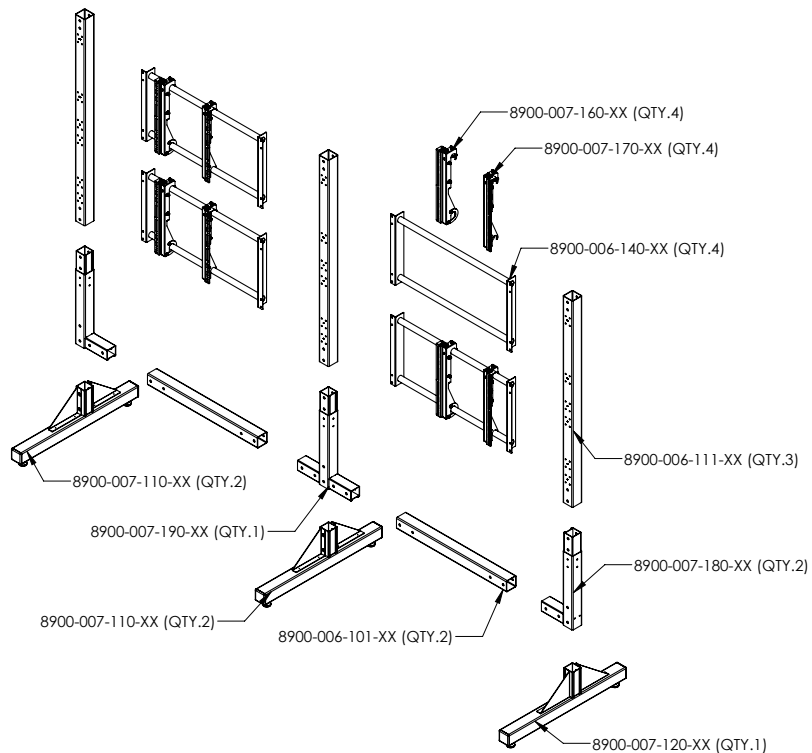

Step 1.

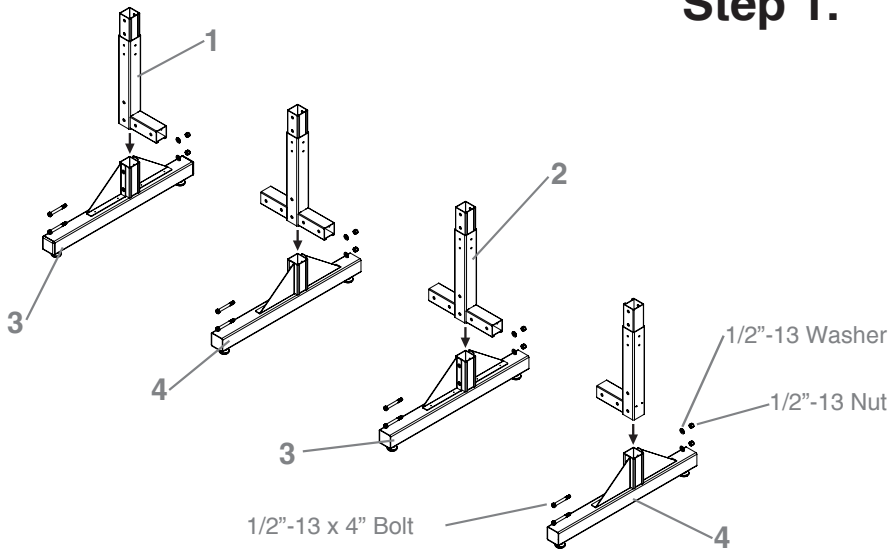

Using 1/2"-13 bolt, nut and washer, bolt together part# 1 (8900-007-180-XX) and part# 2 (8900-007-190-XX) to part# 3 (8900-007-110-XX) and part# 4 (8900-007-120-XX). The MVWS-3X3-55 has four sections and the MVWS-2X2-4655 has three sections.

Step 2.

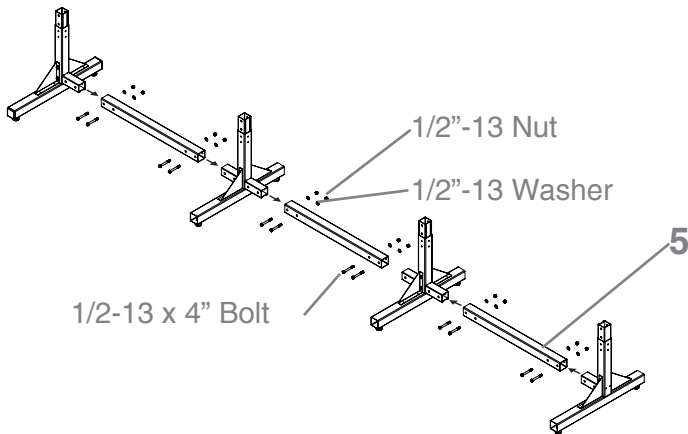

Using 1/2"-13 bolt, nut and washer, attach part# 5 (8900-007-101-XX) to the previously assembled components. The MVW-3X3-55 has three of part# 5 and the MVWS-2X2-4655 has two of part# 5.

Step 3.

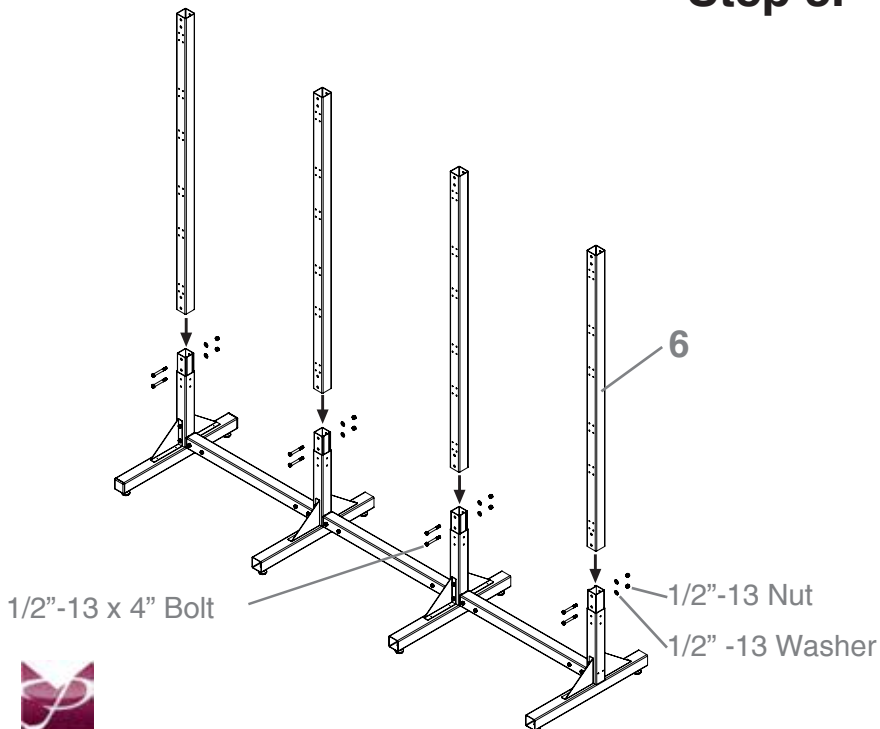

Using 1/2"-13 bolt, nut and washer, attach part# 6 (8900-007-111-XX for MVWS-3X3-55, 8900-006-111-XX for MVWS-2X2-4655) to the assembly. The MVW-3X3-55 has four of part# 6 and the MVWS-2X2-4655 has three of part# 6.



Step 4.

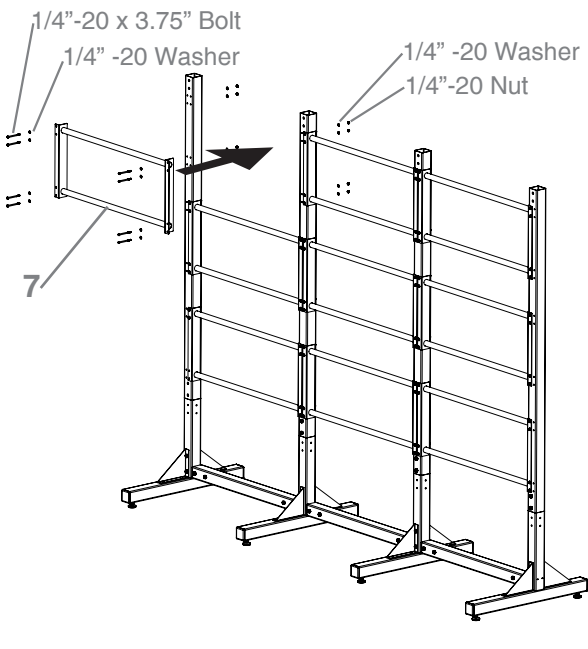

Using 1/4"-20 bolt, nut and two washers, attach part# 7 (8900-007-140-XX for MVWS-3X3-55, 8900-006-140-XX for MVWS-2X2-4655) to the assembly. The MVW-3X3-55 has nine of part# 6 and the MVWS-2X2-4655 has four of part# 6. The MVWS-2X2-4655 has markings showing the correct positions for the 46" displays and 55" displays.

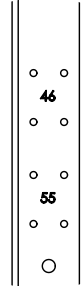

Step 5.

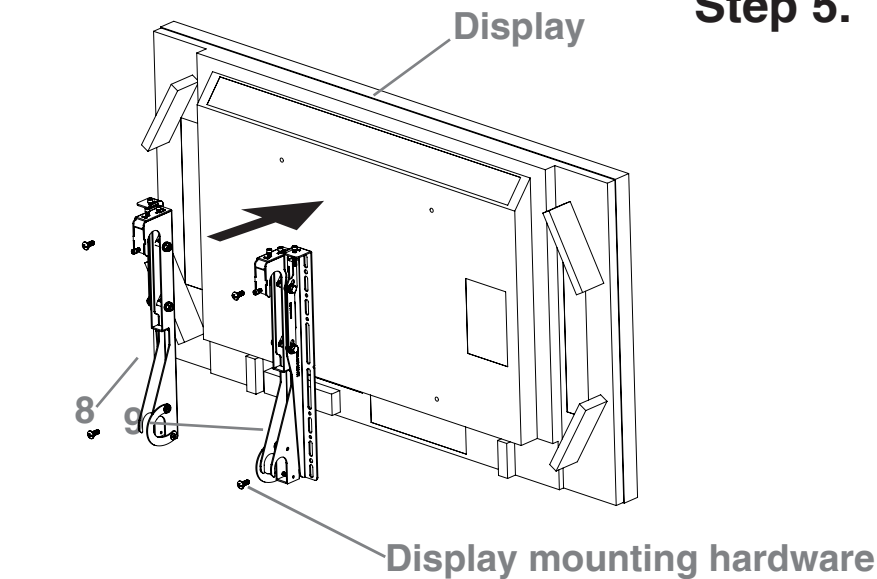

Attach part# 8 (8900-007-170-XX) and part# 9 (8900-007-160-XX) to each display using the correct size hardware for the display used. Use the vesa mounting holes pointed out in the picture.

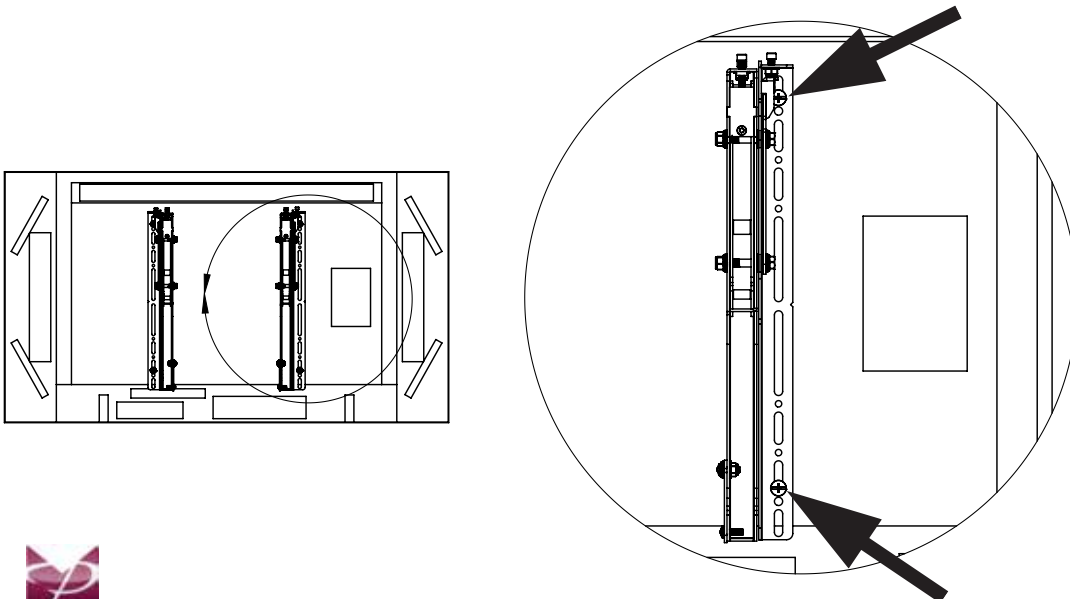

Step 6.

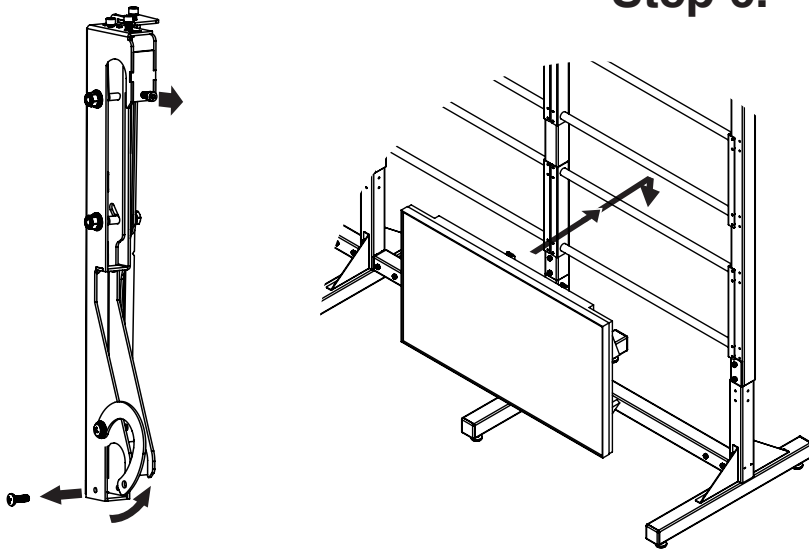

For each display on both of the brackets, back out the rear safety screw to clear the horizontal mounting bar. Remove the screw securing the bottom hook and spin the hook up so that it will clear the horizontal mounting bar. The display can now be installed onto the horizontal tubing.

Step 7.

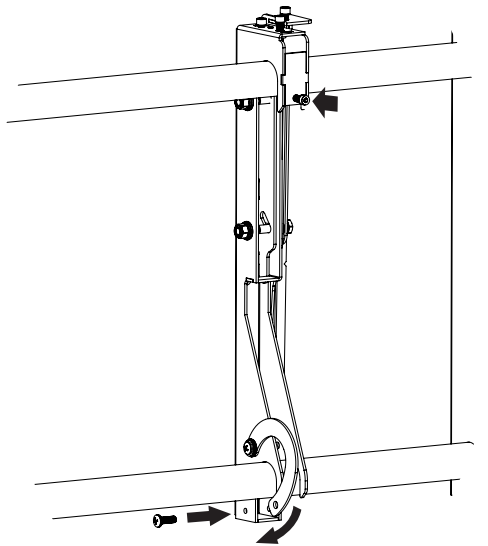

After the display is on the stand in the proper position, tighten the back safety screw so that it is snug (DO NOT OVER TIGHTEN). Rotate the bottom mount safety latch around the vertical mounting bar, and secure it with the previously removed screw.

Step 8.

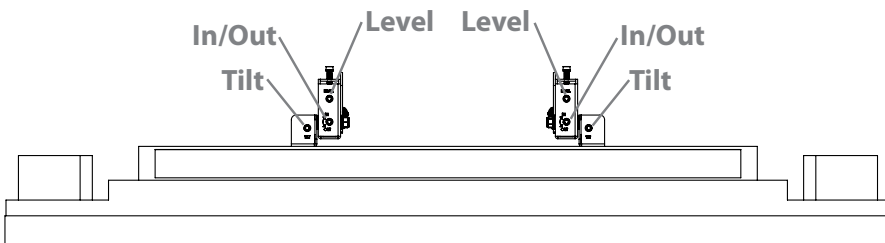

Each bracket has fine tune adjustments that can adjust the level, tilt and in/out of each individual display. Be careful NOT TO OVERTIGHTEN these adjustment screws.

Contact Us

NORTH AMERICA

3130 East Miraloma Avenue
Anaheim, CA 92806 USA
USA and Canada
Phone: 1-800-368-9700
Fax: 1-800-832-4888
Other Locations
Phone: (001) 714-632-7100
Fax: (001) 714-632-1044

EUROPE

Unit 3, The Moorings Business Park,
Channel Way, Longford,
Coventry, CV6 6RH, UK
Phone: +44 (0) 24 7664 4105
Fax: +44 (0) 24 7664 4165

