

Important Safety Instructions

Read and understand all these safety instructions before using the product.











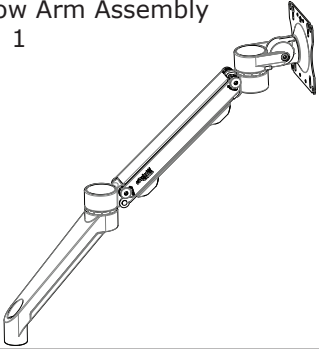
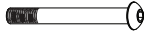
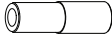



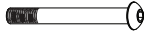
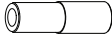



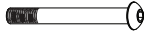
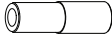



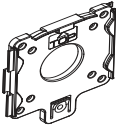





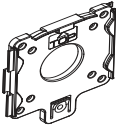





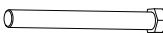

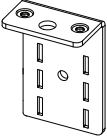





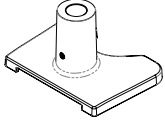
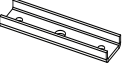

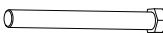

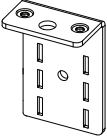





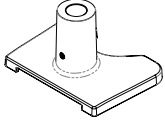
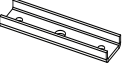
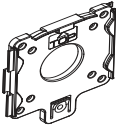

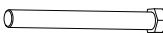

Do not mount the Desk Base of the Willow Arm on an unstable surface or any surface that could not mount the Desk Base firmly.

During installation, beware of the recoil of the Willow Arm body when attaching or detaching the monitor to the Willow Arm. To prevent damage or injury when changing the monitor, always raise the Arm to its highest position before the monitor is detached. *The Willow Arm can support monitors from 1 to 14 pounds.*

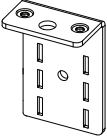
Do not attempt to disassemble, service or modify the product.

Use only a slightly damp cloth to clean the Willow Arm surface. Never use flammable solvents like alcohol, benzene, thinner, etc. on the product.

Parts grouped as shipped

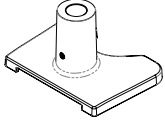
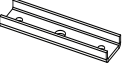
<p>A Willow Arm Assembly Qty: 1</p> 	<table border="0"> <tr> <td data-bbox="691 791 1084 947"> <p>J 3/8" x 16 x 3 1/2" Button Head Allen Cap Screw Qty: 1</p>  </td> <td data-bbox="1101 791 1243 947"> <p>K Pivot Pin Qty: 1</p>  </td> <td data-bbox="1260 791 1528 947"> <p>L 3/8" Steel Washer Qty: 1</p>  </td> </tr> <tr> <td data-bbox="691 968 1003 1157"> <p>M Plastic Pivot Washer Qty: 1</p>  </td> <td data-bbox="1019 968 1243 1157"> <p>N 7/32" Allen Wrench Qty: 1</p>  </td> <td data-bbox="1260 968 1528 1157"> <p>O 1/8" Allen Wrench Qty: 1</p>  </td> </tr> </table>			<p>J 3/8" x 16 x 3 1/2" Button Head Allen Cap Screw Qty: 1</p> 	<p>K Pivot Pin Qty: 1</p> 	<p>L 3/8" Steel Washer Qty: 1</p> 	<p>M Plastic Pivot Washer Qty: 1</p> 	<p>N 7/32" Allen Wrench Qty: 1</p> 	<p>O 1/8" Allen Wrench Qty: 1</p> 															
<p>J 3/8" x 16 x 3 1/2" Button Head Allen Cap Screw Qty: 1</p> 	<p>K Pivot Pin Qty: 1</p> 	<p>L 3/8" Steel Washer Qty: 1</p> 																						
<p>M Plastic Pivot Washer Qty: 1</p> 	<p>N 7/32" Allen Wrench Qty: 1</p> 	<p>O 1/8" Allen Wrench Qty: 1</p> 																						
<table border="0"> <tr> <td data-bbox="94 1163 386 1457"> <p>B Quick Release Bracket Qty: 1</p>  </td> <td data-bbox="402 1163 675 1331"> <p>F 10mm Plastic Spacers Qty: 4</p>  </td> </tr> <tr> <td data-bbox="94 1457 386 1625"> <p>C M4 x 18 Phillips Screws Qty: 4</p>  </td> <td data-bbox="402 1352 675 1520"> <p>G Pivot Cover Cap Qty: 1</p>  </td> </tr> <tr> <td data-bbox="94 1625 386 1751"> <p>D M4 x 12 Phillips Screws Qty: 4</p>  </td> <td data-bbox="402 1520 675 1751"> <p>H 3/16" Allen Wrench Qty: 1</p>  </td> </tr> </table>	<p>B Quick Release Bracket Qty: 1</p> 	<p>F 10mm Plastic Spacers Qty: 4</p> 	<p>C M4 x 18 Phillips Screws Qty: 4</p> 	<p>G Pivot Cover Cap Qty: 1</p> 	<p>D M4 x 12 Phillips Screws Qty: 4</p> 	<p>H 3/16" Allen Wrench Qty: 1</p> 	<p style="text-align: center;">OR</p> <table border="0"> <tr> <td colspan="2" data-bbox="691 1352 1243 1352" style="text-align: center;">WA1000-C-S only</td> <td data-bbox="1260 1310 1528 1352" style="text-align: center;">WA1000-G-S only</td> </tr> <tr> <td data-bbox="691 1352 964 1520"> <p>P Upper Clamp Bracket Qty: 1</p>  </td> <td data-bbox="964 1352 1243 1520"> <p>S 3/8" x 16 x 3 1/2" Hex Bolt Qty: 1</p>  </td> <td data-bbox="1260 1352 1528 1520"> <p>V 3/8" x 16 x 4 1/2" Threaded Stud Qty: 1</p>  </td> </tr> <tr> <td data-bbox="691 1520 964 1772"> <p>Q Lower Clamp Bracket Qty: 1</p>  </td> <td data-bbox="964 1520 1243 1772"> <p>T Plastic Clamp Knob Qty: 1</p>  </td> <td data-bbox="1260 1520 1528 1688"> <p>W 3/8" x 16 Hex Nut Qty: 1</p>  </td> </tr> <tr> <td data-bbox="691 1772 964 1997"> <p>R 1/4" x 20 x 3/8" Phillip Flat Head Screws Qty: 2</p>  </td> <td data-bbox="964 1772 1243 1997"> <p>U Plastic Clamp Pad Qty: 1</p>  </td> <td data-bbox="1260 1688 1528 1856"> <p>X 3/8" Steel Washer Qty: 1</p>  </td> </tr> <tr> <td data-bbox="391 1751 675 1997"> <p>I Desk Base Qty: 1</p>  </td> <td data-bbox="1260 1856 1528 1997"> <p>Y U-Bracket Qty: 1</p>  </td> <td></td> </tr> </table>			WA1000-C-S only		WA1000-G-S only	<p>P Upper Clamp Bracket Qty: 1</p> 	<p>S 3/8" x 16 x 3 1/2" Hex Bolt Qty: 1</p> 	<p>V 3/8" x 16 x 4 1/2" Threaded Stud Qty: 1</p> 	<p>Q Lower Clamp Bracket Qty: 1</p> 	<p>T Plastic Clamp Knob Qty: 1</p> 	<p>W 3/8" x 16 Hex Nut Qty: 1</p> 	<p>R 1/4" x 20 x 3/8" Phillip Flat Head Screws Qty: 2</p> 	<p>U Plastic Clamp Pad Qty: 1</p> 	<p>X 3/8" Steel Washer Qty: 1</p> 	<p>I Desk Base Qty: 1</p> 	<p>Y U-Bracket Qty: 1</p> 	
<p>B Quick Release Bracket Qty: 1</p> 	<p>F 10mm Plastic Spacers Qty: 4</p> 																							
<p>C M4 x 18 Phillips Screws Qty: 4</p> 	<p>G Pivot Cover Cap Qty: 1</p> 																							
<p>D M4 x 12 Phillips Screws Qty: 4</p> 	<p>H 3/16" Allen Wrench Qty: 1</p> 																							
WA1000-C-S only		WA1000-G-S only																						
<p>P Upper Clamp Bracket Qty: 1</p> 	<p>S 3/8" x 16 x 3 1/2" Hex Bolt Qty: 1</p> 	<p>V 3/8" x 16 x 4 1/2" Threaded Stud Qty: 1</p> 																						
<p>Q Lower Clamp Bracket Qty: 1</p> 	<p>T Plastic Clamp Knob Qty: 1</p> 	<p>W 3/8" x 16 Hex Nut Qty: 1</p> 																						
<p>R 1/4" x 20 x 3/8" Phillip Flat Head Screws Qty: 2</p> 	<p>U Plastic Clamp Pad Qty: 1</p> 	<p>X 3/8" Steel Washer Qty: 1</p> 																						
<p>I Desk Base Qty: 1</p> 	<p>Y U-Bracket Qty: 1</p> 																							

Verify that you have all the hardware and tools needed for the assembly

Check your packages against the parts list on page 1 to verify that you have all the parts needed. You will also need the following tools:

#3 tip Phillips screwdriver



1 Assemble Base

Clamp Mount: WA1000-C-S only

- a** To assemble Clamp, thread Hex Bolt (S) through Knob (T) and Upper Clamp Bracket (P) and tighten securely. Press the Plastic Clamp Pad (U) onto the end of the Hex Bolt.
- b** Mount Lower Clamp Bracket (Q) to Desk Base with Flat Head Screws (R) and tighten using a #3 Phillips screwdriver.
- c** Put Desk Base (I) onto work surface then slide teeth of Clamp into Bracket slots. Use the highest slots possible for best clamping. Turn knob to tighten.

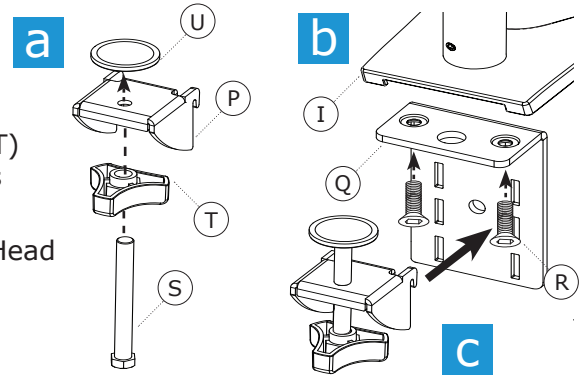

OR

Grommet Mount: WA1000-G-S only

- a** Drill hole in worksurface minimum of $\frac{3}{8}$ " diameter if needed. Put Desk Base (I) directly on the drilled hole of worksurface or a grommet hole up to 3" and insert and tighten the Threaded Stud (V).
- b** Place the U-Bracket (Y) onto the Threaded Stud with the flat bottom of the U facing down.
- c** Place the Steel Washer (X) followed by the Hex Nut (W) onto the Threaded Stud and tighten securely.

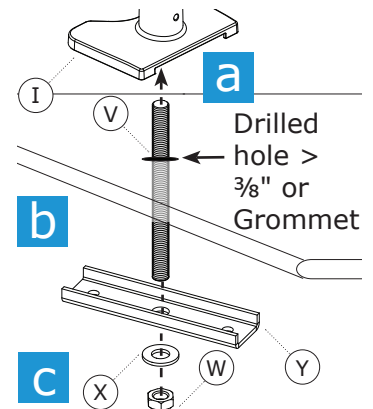

2 Attach Willow Arm to Base

- a** Insert Pivot Pin (K) into Desk Base Assembly (I).
- b** Put Plastic Pivot Washer (M) over Pivot Pin.
- c** Put Arm Assembly (A) onto Pivot Pin.
- d** Place Steel Washer (L) onto Button Head Allen Bolt (J) and install into the Arm assembly and base. Tighten with $\frac{7}{32}$ " Allen Wrench (N) – be sure the arm is snug but rotates freely.
- e** Tighten Set Screw in back of Desk Base with $\frac{1}{8}$ " Allen Wrench (O).
- f** Snap Pivot Cover Cap (G) into top of Arm Assembly.

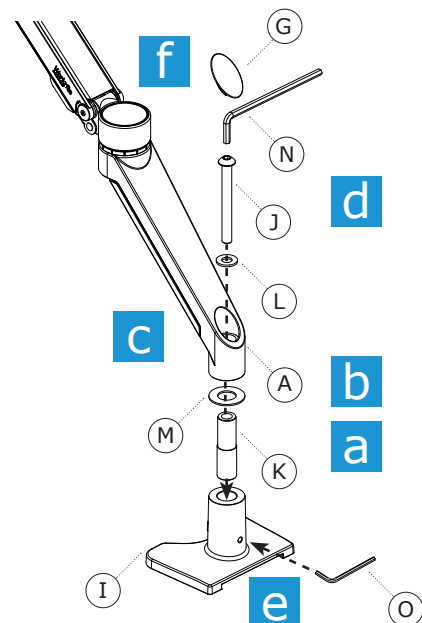

3 Attach to Monitor



Important Note

It is strongly recommended to use the mounting screws provided by the monitor manufacturer if possible. If longer screws are needed, use either part (C) 18mm long, (D) 12mm long, or (E) 8mm long. NOTE: Always use the shortest screws possible to avoid damage to the monitor.

Quick Release Option:

- a** Attach the Quick Release Bracket (B) to the VESA mount holes on your monitor. Use the screws from your monitor if possible. The tab on the bracket should be on the bottom.

For Recessed Mounts:

For monitors with recessed mount where the Quick Release Bracket will not fit into the mounting location, 10mm Plastic Spacers (F) have been supplied. Install these between the monitor and the Quick Release Bracket as shown with the shortest M4 screws possible.

- b** Attach the Willow Arm to the monitor by sliding the Quick Release Bracket over the mounting plate.

Note: Your Quick Release Bracket has convenient storage on its sides for the $\frac{3}{16}$ " Allen Wrench (H) and the $\frac{1}{8}$ " Allen Wrench (O).

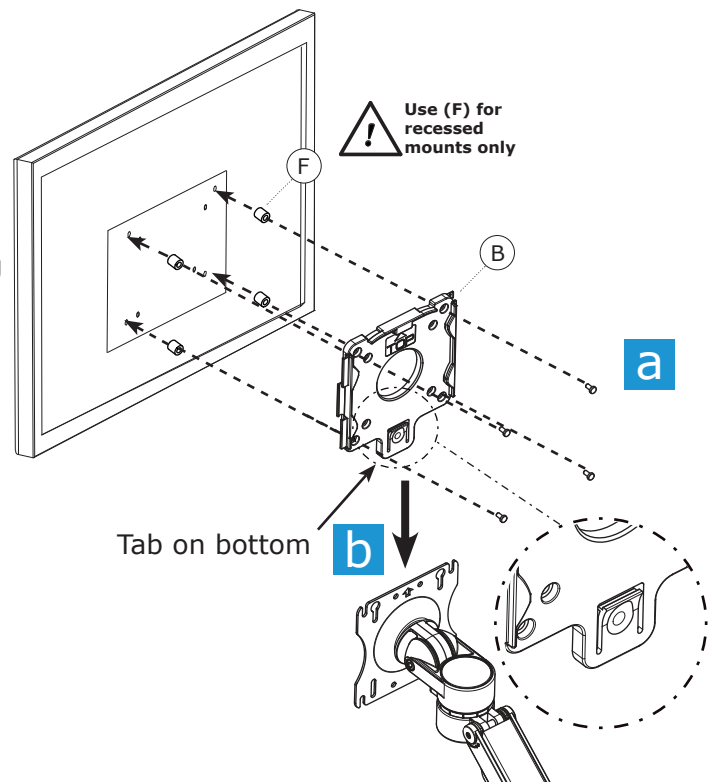
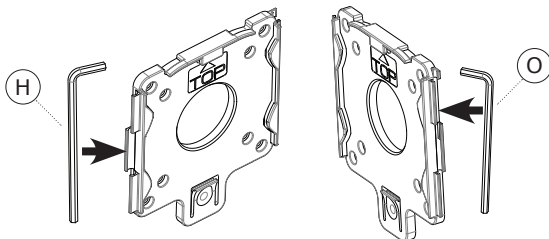

OR

Direct/Secure Mount Option:

- a** Attach the Willow Arm VESA mount to the VESA mount holes on your monitor. Use the screws from your monitor if possible. The clip on the bracket should be on the bottom.

For Recessed Mounts:

For monitors with recessed area where the VESA mount will not fit into the mounting location, 10mm Plastic Spacers (F) have been supplied. Install these between the monitor and the VESA mount as shown with the shortest M4 screws possible.

Note: Keep your Quick Release Bracket (B) for possible future use.

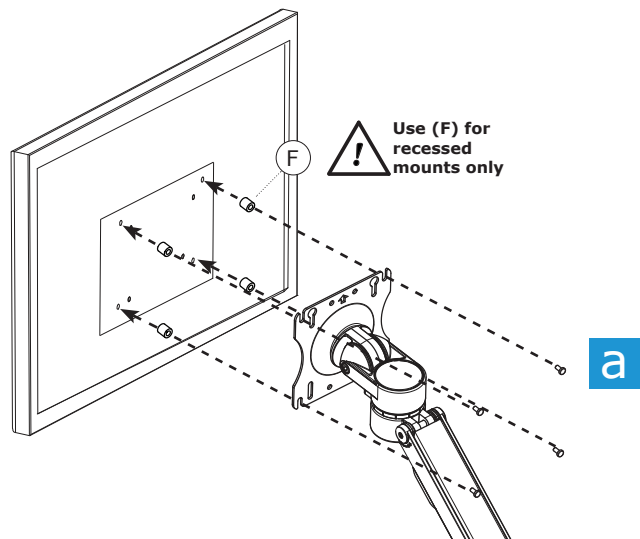

4 Cable Management

- a** Upper arm: Insert cables into the recessed area under the upper arm by spreading the clips apart.
- b** Lower arm: Pull cover off the underside of the extension, place cables into recess, then snap cover back on.
- c** Desk Base: If using the Grommet Mount, you can thread cables into the grommet hole using the indentation in the base.

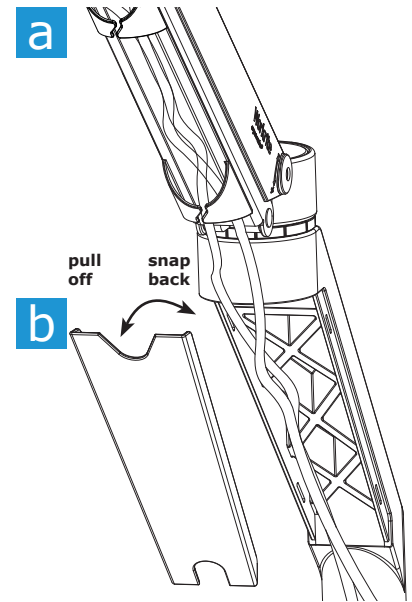
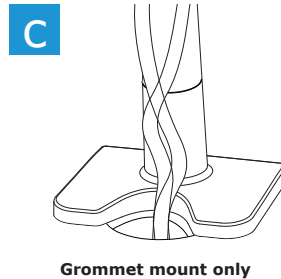

5 Adjust the Monitor Tilt Action

Depending on the size of your monitor, it may be necessary to adjust the tilt setting.

If the monitor doesn't hold its tilt position or is too hard to tilt, adjust the screw directly behind the monitor on the side of the arm. Use the $\frac{3}{16}$ " Allen Wrench (H) (clockwise to tighten, counter-clockwise to loosen). Check the monitor, and adjust again as necessary.

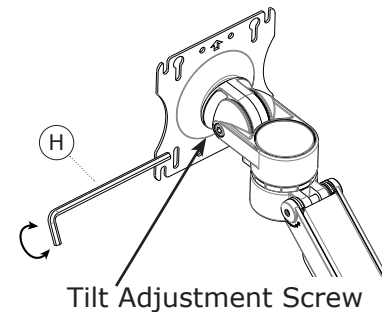

6 Adjust the Monitor Vertical Movement

The Willow Arm is preset to balance a 6-pound monitor. If your monitor weighs more or less than this, it may be necessary to adjust the friction of the arm. Test the friction by raising the arm all the way up, waiting to see if it moves, and then lowering the arm all the way down. If the arm drops from the top or rises off the bottom, you will need to adjust the friction.

Use the $\frac{3}{16}$ " Allen Wrench (H) to make small adjustments in the arm friction by turning the screws in each end of the upper arm. Always turn both screws the same amount in small steps, until the arm no longer rises or falls. Do not overtighten or the arm will be too stiff to make easy adjustments in monitor position.

