

Sierra Electric

Adjustable Height Workcenters — Electric, Sit-to-Stand

EXCLUSIVE
5TH - 95TH
Height Range
ANSI/BIFMA

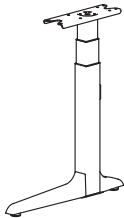

Install two-leg base with only four screws



In-desk control panel shown; can also mount under worksurface



Base-only versions integrate with virtually all systems' worksurfaces



Over 50 standard laminate options available

Bringing Comfort to New Heights

Today's diverse workforce requires workcenters that fit the entire range of body shapes and sizes. Only Sierra provides 5th - 95th percentile height adjustability for the complete worksurface. New accessories including modesty screen, tool bar, and power/data supply make Sierra the complete ergonomic workcenter solution.

Achieves unrivalled height range - in seconds

Sierra's peak height of 48" surpasses the ANSI/BIFMA standard by more than 2"! Adjusts at 2" per second to quickly reach any comfort level.

Facilities-friendly design

Facilities managers will appreciate the level of preassembly built into the Sierra. It only takes 4 screws to assemble a two leg table base. Securing the worksurface and controls is just as easy. Workrite also offers a diagnostic kit for convenient on-site servicing.

Advanced Controls

Sierra's exclusive backlit LCD control panel has tactile soft-touch control buttons and 3 programmable memory height presets.

Suited to any space

Consider base-only solutions when you want to preserve the look and feel of your configuration or protect the investment in your worksurfaces.

Surface colors for every taste

With more than 50 in-stock laminate selections, including 8 thermofoil patterns, integrating Sierra workcenters into your environment is easier than ever.

At Workrite we believe every body has a right to work comfortably and safely for maximum productivity. You can trust Workrite, as 75% of Fortune 100 companies have, for solutions that fit today's diverse range of workers.

Sierra Electric Adjustable Height Workcenters — Electric, Sit-to-Stand

Straight

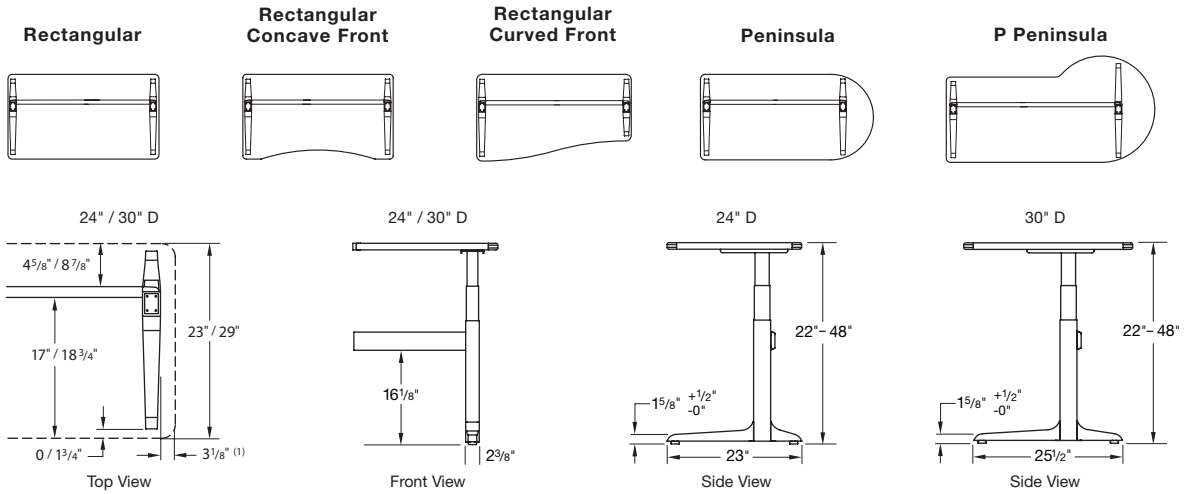

1) For Peninsula and P Peninsula worksurfaces, this distance is 12" and 15" respectively (from outermost edge)

Small Corner

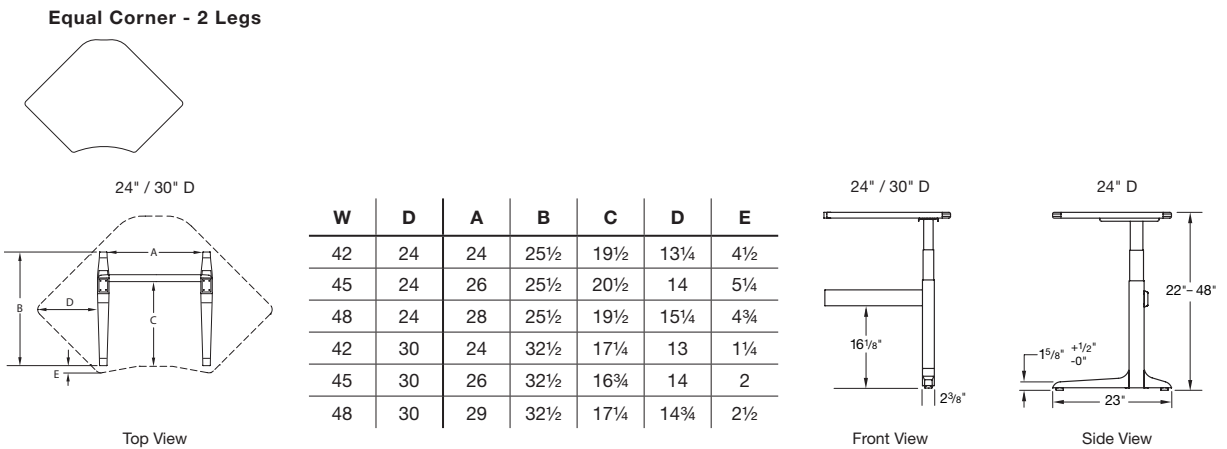

Three-Leg Corner

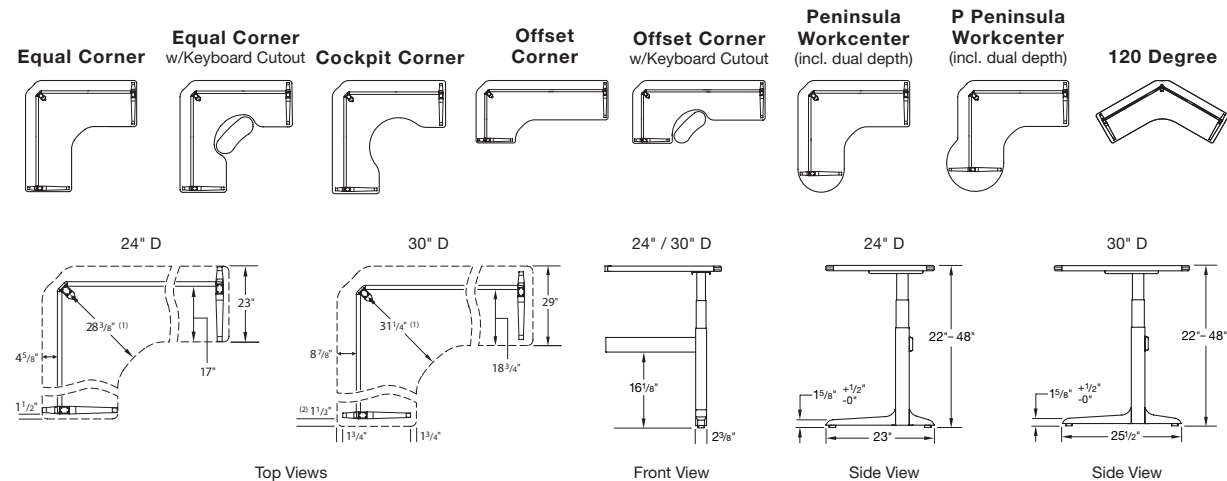

1) 120 Degree Tables: 19¹/₂" / 24¹/₂" 2) 120 Degree Tables: 5"; all Peninsula ends: 15"

The following are federally registered trademarks of Workrite Ergonomics: Workrite Ergonomics®. The following is a trademark of Workrite Ergonomics: Workrite Sierra™, Intuitive work tools for every body™.

Printed with 25% post-consumer waste, 50% total recycled content.

CSW-SEL-0108 ©2008 Contents subject to change without notice.

Workrite Ergonomics, Inc.
1450 Technology Lane,
Petaluma, CA 94954
www.workriteergo.com
800.959.9675

Workrite
ergonomics®

