

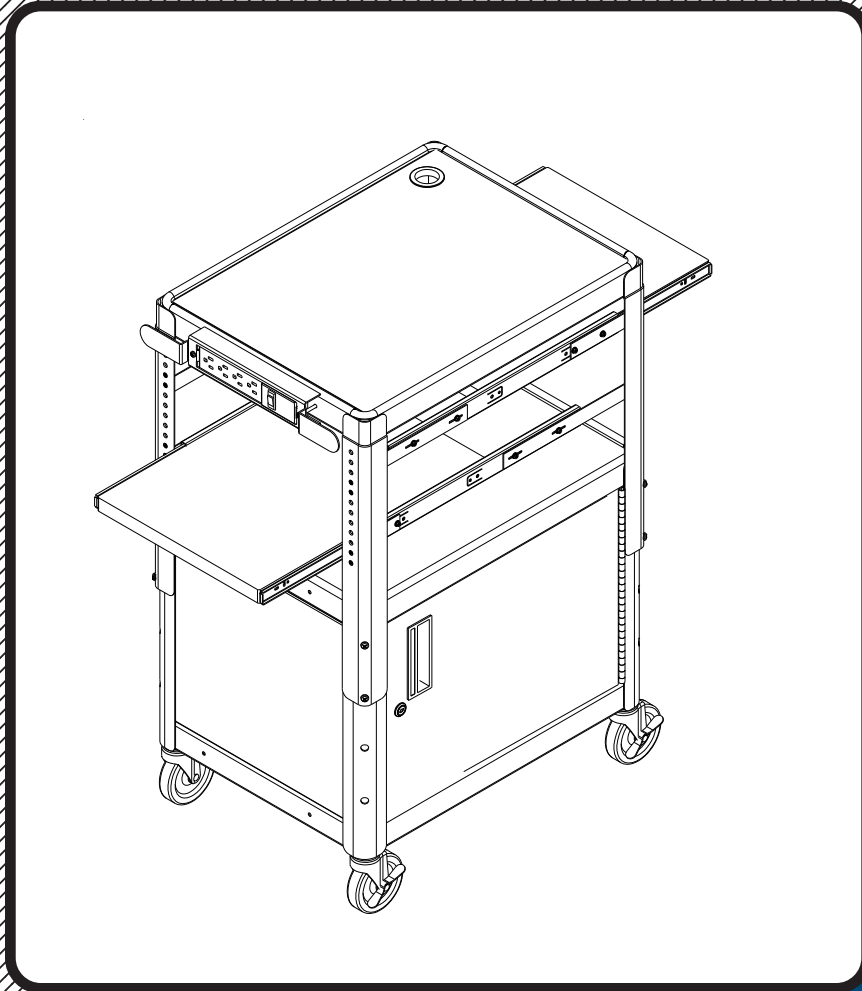







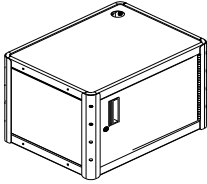

#89875 Dual Adjustable Laptop Cart

with 2 Pull-out Shelves & Locking Cabinet

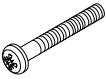

Assembly Instructions

#89875 Dual Adjustable Laptop Cart

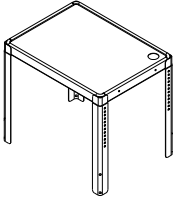
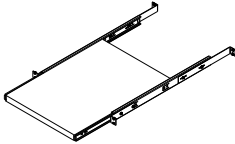
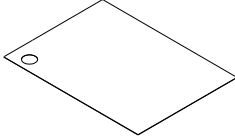
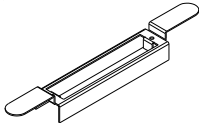
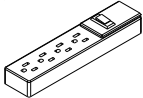
Part	Drawing	Description	Qty	Part	Drawing	Description	Qty				
P1		Base Cabinet	1 EA	<p style="text-align: center;">Hardware List</p> <p>A  Screw M6X12mm Pan Hd 8 EA</p> <p>A1  Screw M3.5X12mm CS 16 EA</p> <p>A2  Screw M5X45mm Pan Hd 2 EA</p> <p>B  Hex nut M6 8 EA</p> <p>B1  Hex nut M3.5 16 EA</p> <p>B2  Hex nut M5 w/Flange 2 EA</p> <p>C  Lock Washer Ext Tooth (For M6 Screw) 8 EA</p> <p>D  4" Locking Caster 2 EA</p> <p>E  4" Caster 2 EA</p>							
P2		Top Shelf	1 EA								
P3		Pull-out Shelf	2 EA								
P4		Rubber Mat	1 EA								
P5		Cord Winder	1 EA								
P6		Electrical Outlet	1 EA								
<p><i>We recommend that you assemble this unit on a table.</i></p> <p>Tools required: Adjustable Crescent Wrench</p>								<p style="text-align: center;">Missing Parts or UPS Damaged Parts</p> <p style="text-align: center;">For Your Convenience you can EMAIL us at <i>furniture@baltinc.com</i> 24HOURS 7 DAYS A WEEK</p>			

Do not use unless all screws are tight. At least every six months, check all screws to be sure they are tight. If parts are missing, broken, damaged, or worn, stop use of the product until repairs are made by your dealer using factory authorized parts.

#89875 Dual Adjustable Laptop Cart Assembly Diagram



READ THROUGH INSTRUCTIONS FROM BEGINNING TO END BEFORE STARTING TO ASSEMBLE UNIT.

1.) Identify and Separate all the Parts and Hardware.

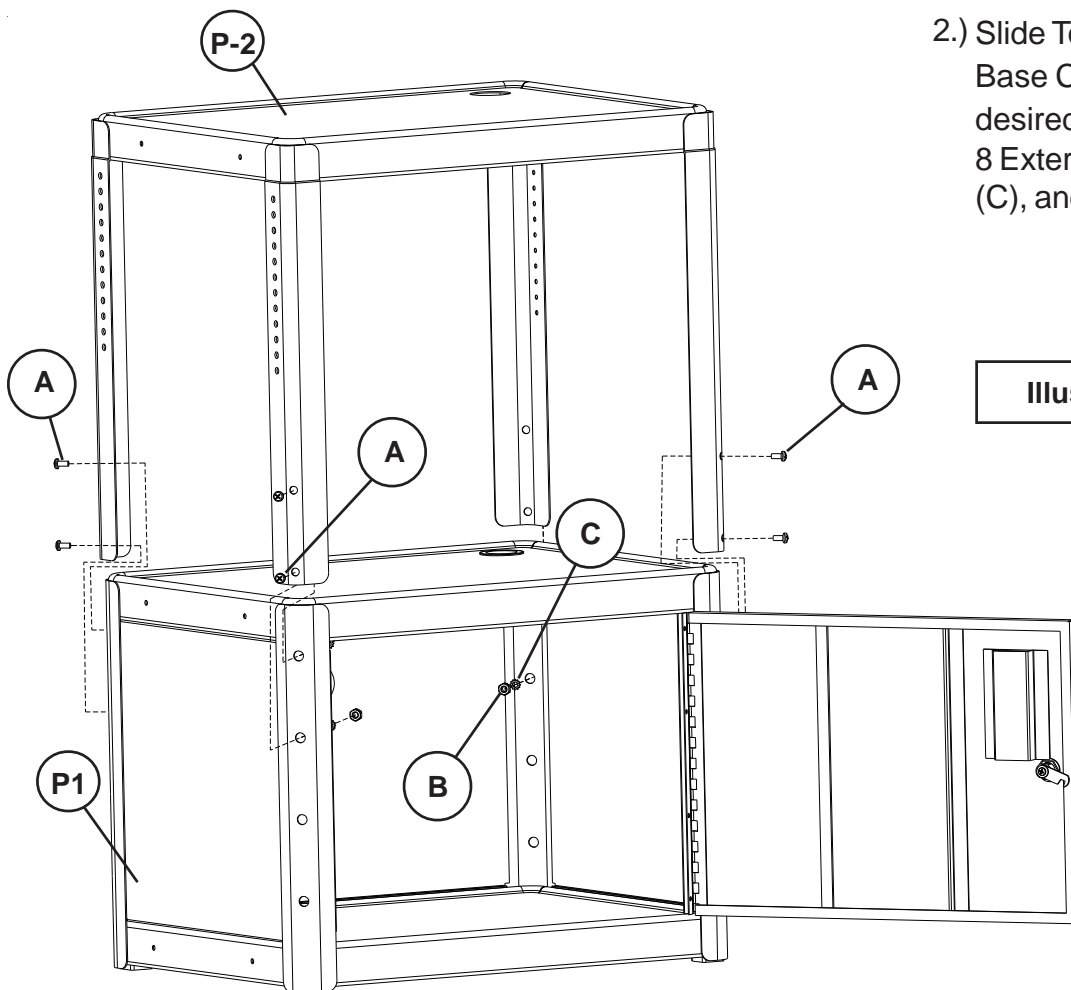

2.) Slide Top Shelf (P-2) over the Base Cabinet (P-1) and secure at desired height using 8 screws (A), 8 External Tooth Lock Washers (C), and 8 Hex Nuts (B).

Illustration # 1

3.) Press 2 Locking Casters (D) and 2 non-locking casters (E) into the factory installed nylon inserts in the Base Cabinet (P-1) as shown in illustration #2.

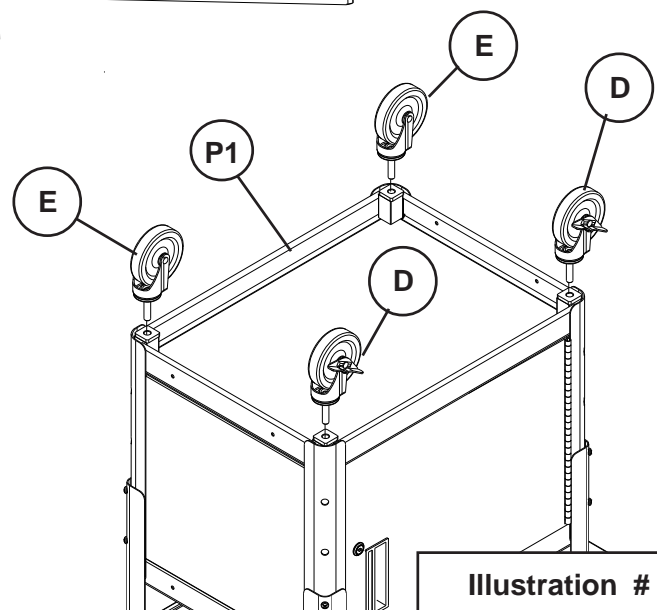
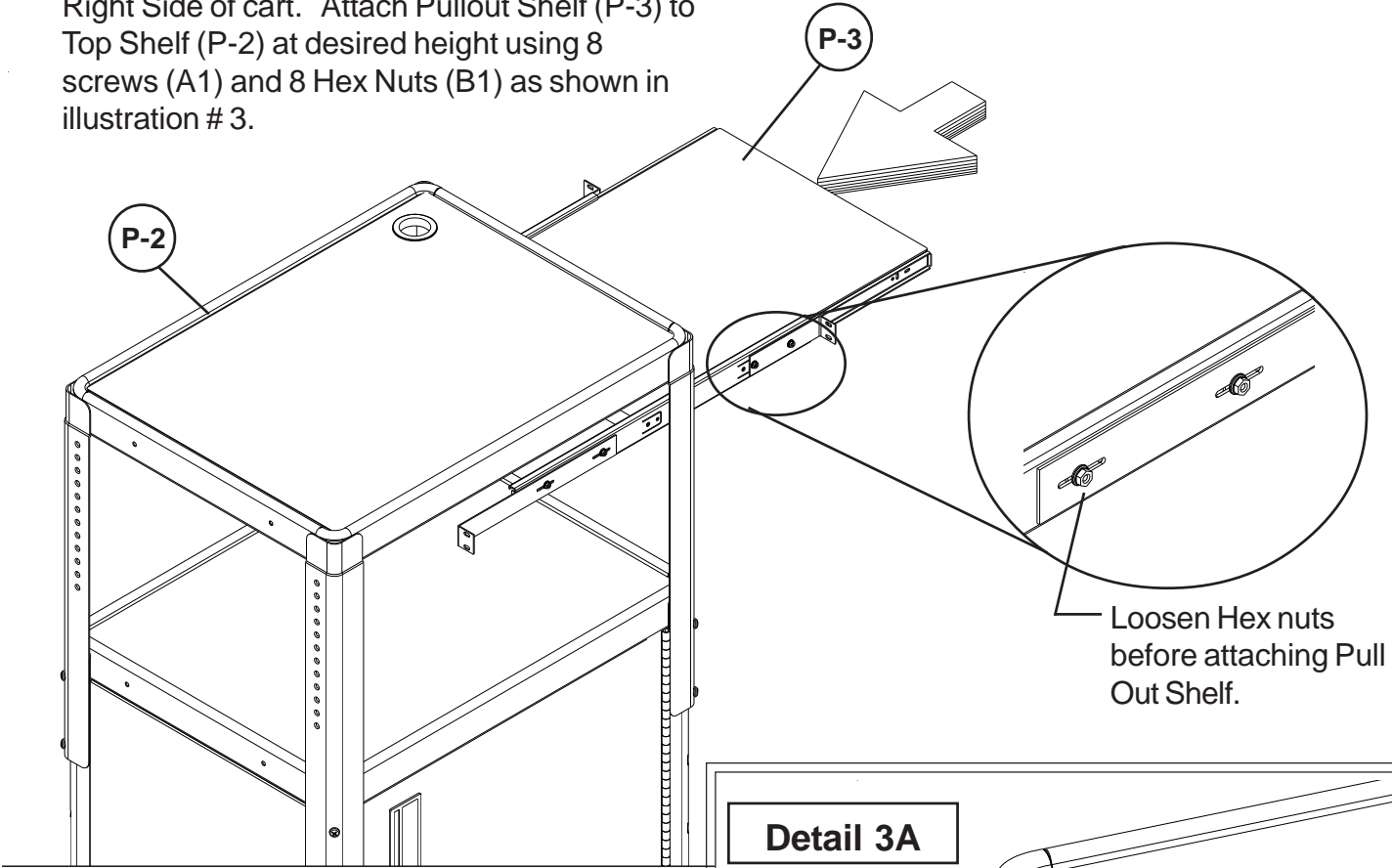

Illustration # 2

Illustration # 3

4.) Tilt 1 Pullout Shelf (P-3) and slide in from the Right Side of cart. Attach Pullout Shelf (P-3) to Top Shelf (P-2) at desired height using 8 screws (A1) and 8 Hex Nuts (B1) as shown in illustration # 3.



5.) Tilt 1 Pullout Shelf (P-3) and slide in from the Left Side of cart. Attach Pullout Shelf (P-3) to Top Shelf (P-2) at desired height using 8 screws (A1) and 8 Hex Nuts (B1) as shown in illustration # 4.

Illustration # 4

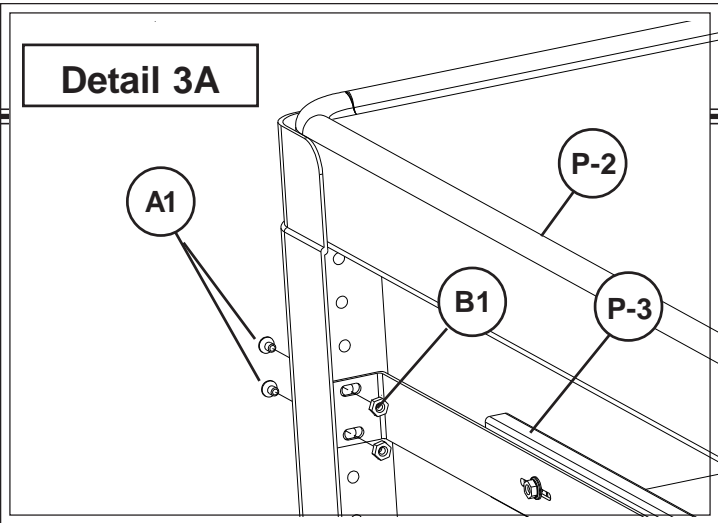
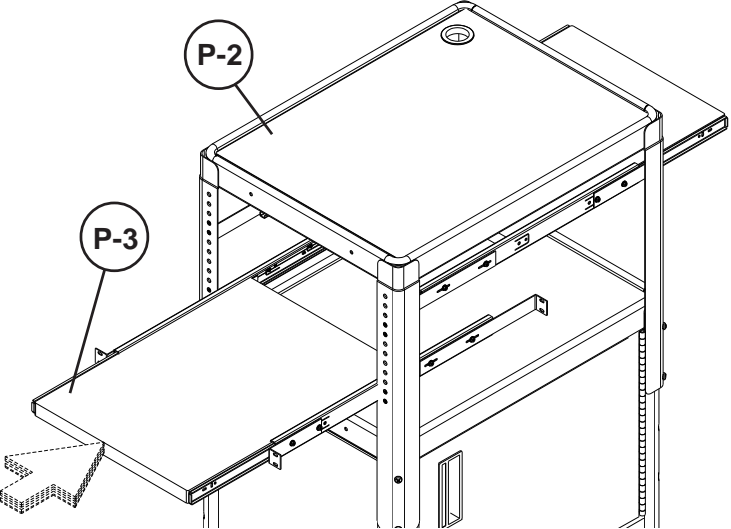

**Should you require assistance during assembly,
please call our Customer Service
Department Monday - Friday
8 a.m. - 5 p.m.
Central Standard Time
1-800-749-2258**



- 6.) Remove Plastic Grommet and place Rubber Mat (P-4) on the Top Shelf (P-2). Insert Plastic Grommet into hole in Mat (P-4) and Top Shelf (P-2) as shown in illustration #5.
- 7.) Attach Cord Winder (P-5) and Electrical Strip (P-6) to either side of Top Shelf (P-2), or Base Cabinet (P-1) using 2 screws (A2) and 2 Hex Nuts M5 w/Flange (B2).
- 8.) Tighten all screws using Phillip's head screwdriver and Wrench (Not Provided).

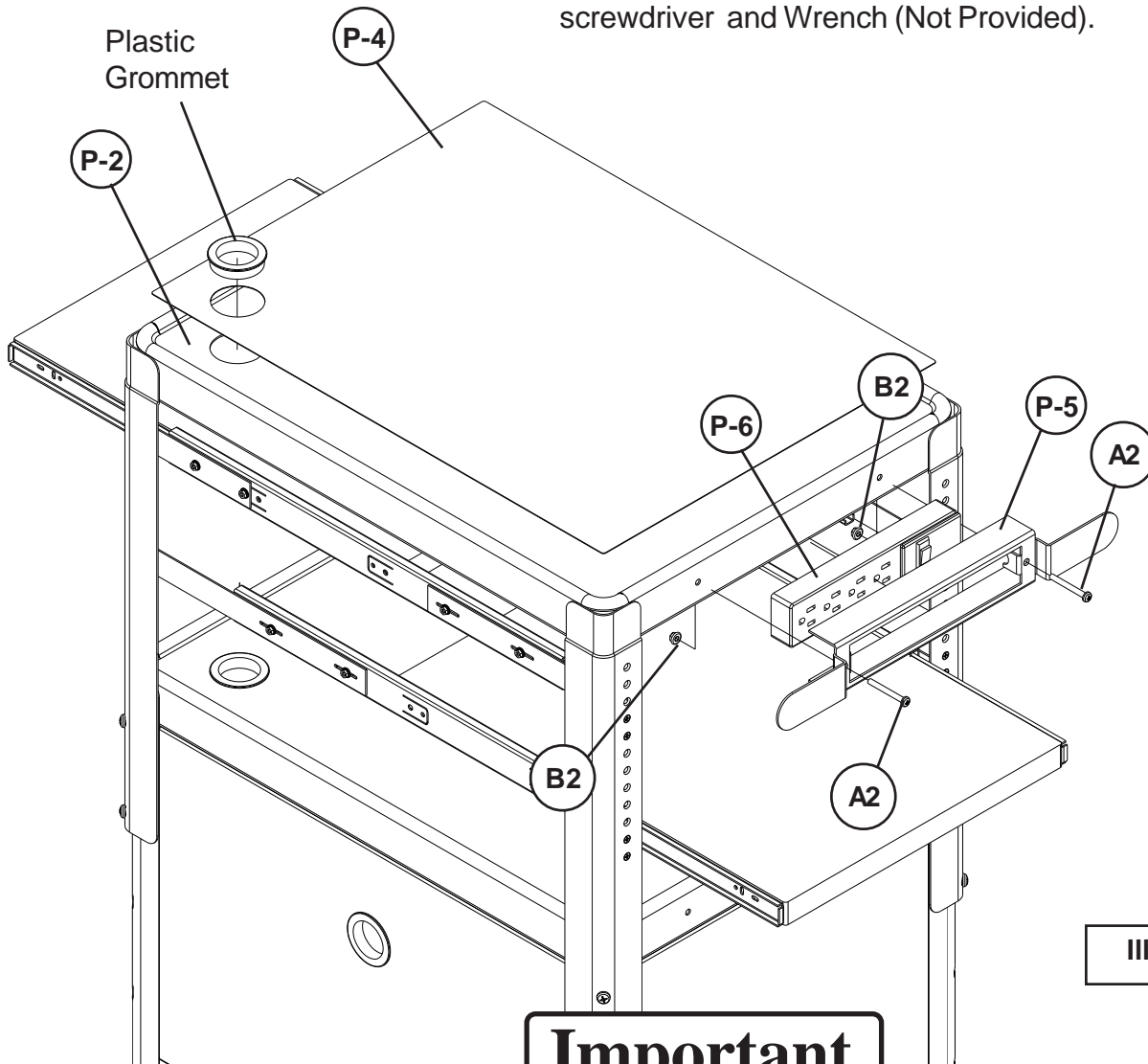

Important

The Balt product you have purchased is guaranteed against material and workmanship defects. This guarantee extends 1 year from date of purchase. Should this product fail to function satisfactorily under normal use due to defect or imperfection, the defective part or product will be replaced. Damage caused by common carriers during shipment is not included in this guarantee.

This guarantee sets forth all applicable guarantees and remedies. No other warranty, expressed or implied shall apply. Failure to follow instructions found in Important Information Section of Owner Sheet shall void the guarantee. Consequential or incidental damages and or costs are not refundable.