

BALT[®]

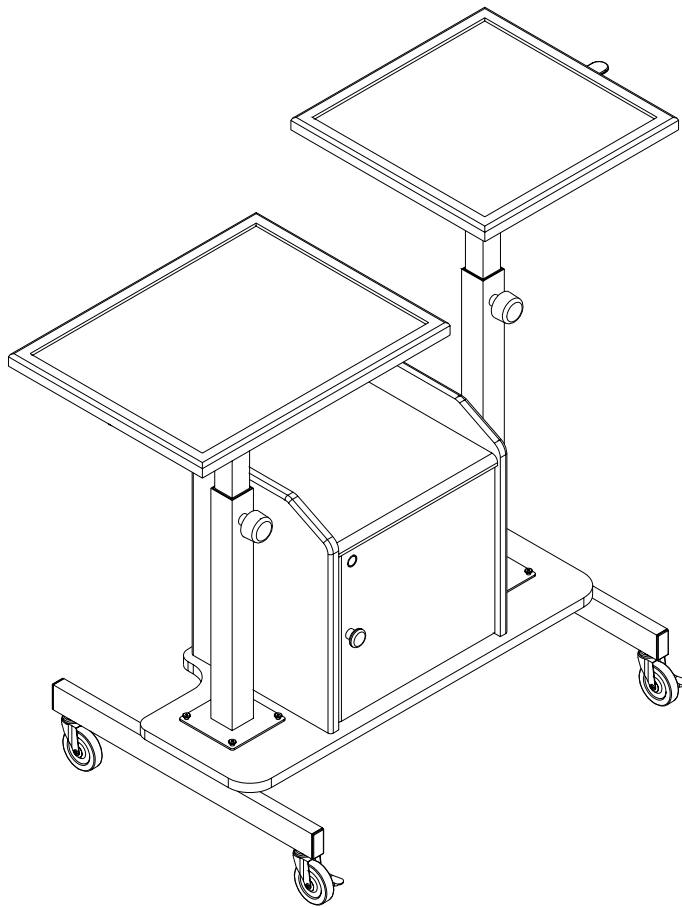









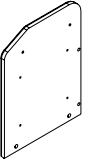
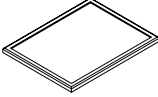
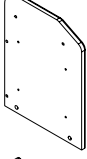
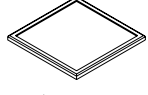

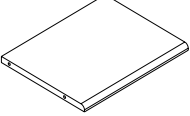
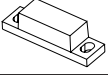
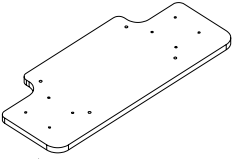
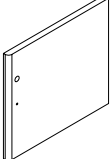

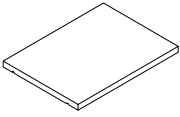
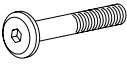
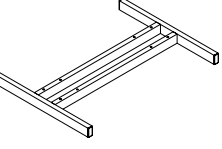

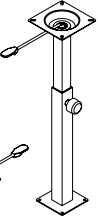

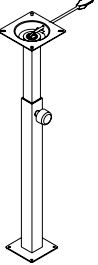

#82692 ProView
Adjustable Height Presentation Stand

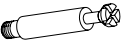

Assembly Instructions

#82692 ProView

Adjustable Height Presentation Stand

Part	Drawing	Description	Qty	Part	Drawing	Description	Qty
P-1		Left Side Panel	1 EA	P-11		Laptop Platform	1 EA
P-2		Right Side Panel	1 EA	P-12		LCD Platform	1 EA
P-3		Back Panel	1 EA	P-13		Door Knob	1 EA
P-4		Top Panel	1 EA	P-14		Door Magnet	1 EA
P-5		Bottom Platform	1 EA	Hardware List			
P-6		Door	1 EA	A		3/8" Flat Head Screw	8 EA
P-7		Removeable Shelf	1 EA	A1		2 1/2" Flat Head Screw	8 EA
P-8		Metal Base	1 EA	A2		Phillips Head Screw (Door Knob)	1 EA
P-9		Short Cylinder	1 EA	A3		Short Wood Screw (4 in box with lock)	6 EA
P-10		Tall Cylinder	1 EA	B		Adjustment Knob (Installed on P-9/P-10 Cylinders)	2 EA
				C		Metal Support Pins	4 EA
				D		3" Locking Caster (for front)	2 EA
				E		3" Caster (for Back)	2 EA
				F		Cam Lock	12 EA
				G		Cam Post	12 EA
				H		Allen Wrench	1 EA
				J		Caster Wrench	1 EA
				K		Key	2 EA
				L		Spring Button (Installed in door)	2 EA
				M		Washer	8 EA
				N		Door Lock	1 EA

#82692 ProView Assembly Diagram



Tools required: Phillips Head Screwdriver

To Assemble:

1. Identify and Separate all the Parts and Hardware.

2. Place the Left Side Panel (P-1) with the Pre-drilled holes facing up and install 4 each Cam Posts (G) in the 4 threaded insert nuts (Pre-installed) as shown in illustration # 1.

3. Install 2 each Cam Locks (F) into the large holes as shown in illustration # 1.

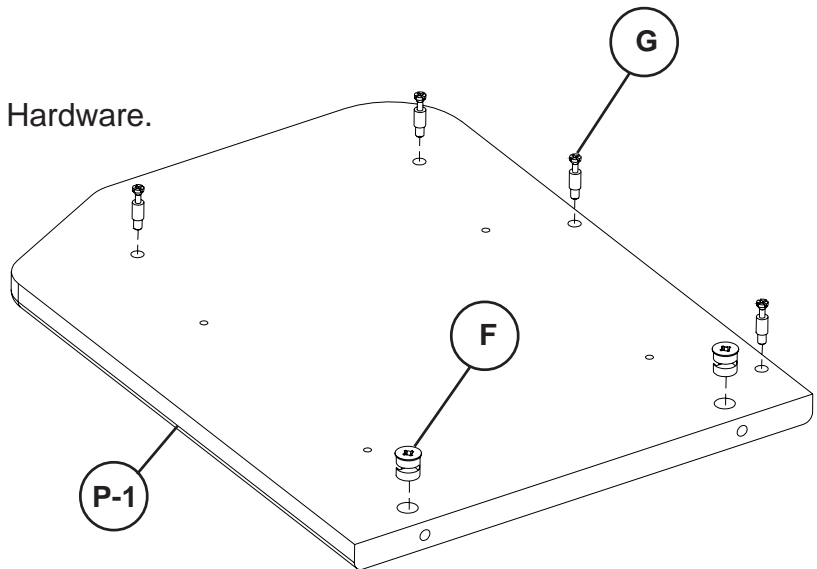

Illustration # 1

4. Place the Right Side Panel (P-2) with the Pre-drilled holes facing up and install 4 each Cam Posts (G) in the 4 threaded insert nuts (Pre-installed) as shown in illustration # 2.

5. Install 2 each Cam Locks (F) into the large holes as shown in illustration # 2.

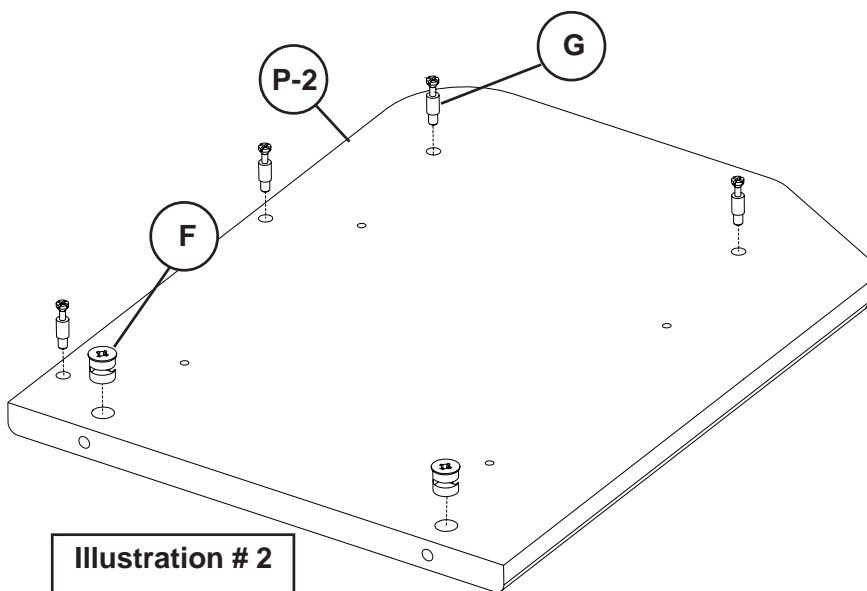
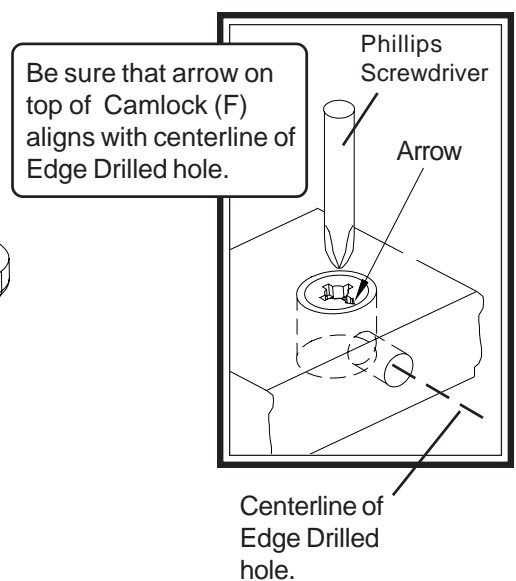
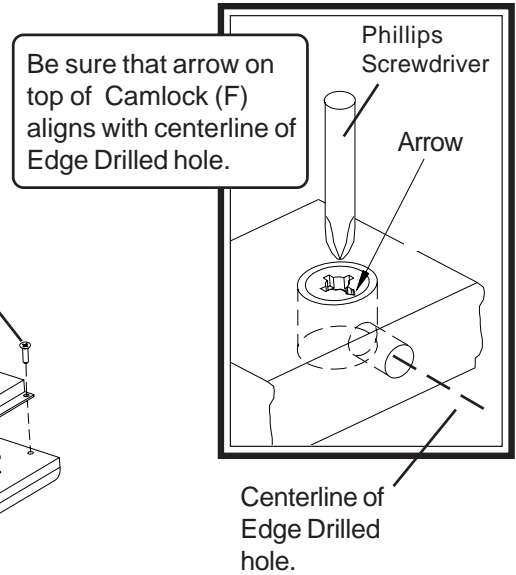
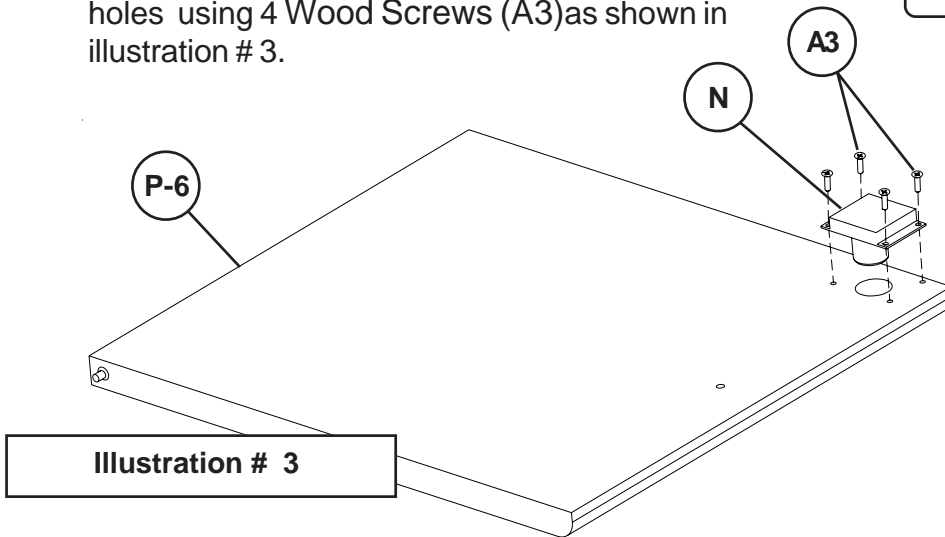

Illustration # 2



6. Place the Door (P-6) with the 4 Screw Holes facing up and install 1 Lock (N) into the large holes using 4 Wood Screws (A3) as shown in illustration # 3.



7. Place the Back Panel (P-3) with the Holes facing up and install 4 each Cam Locks (F) into the large holes as shown in illustration # 4.

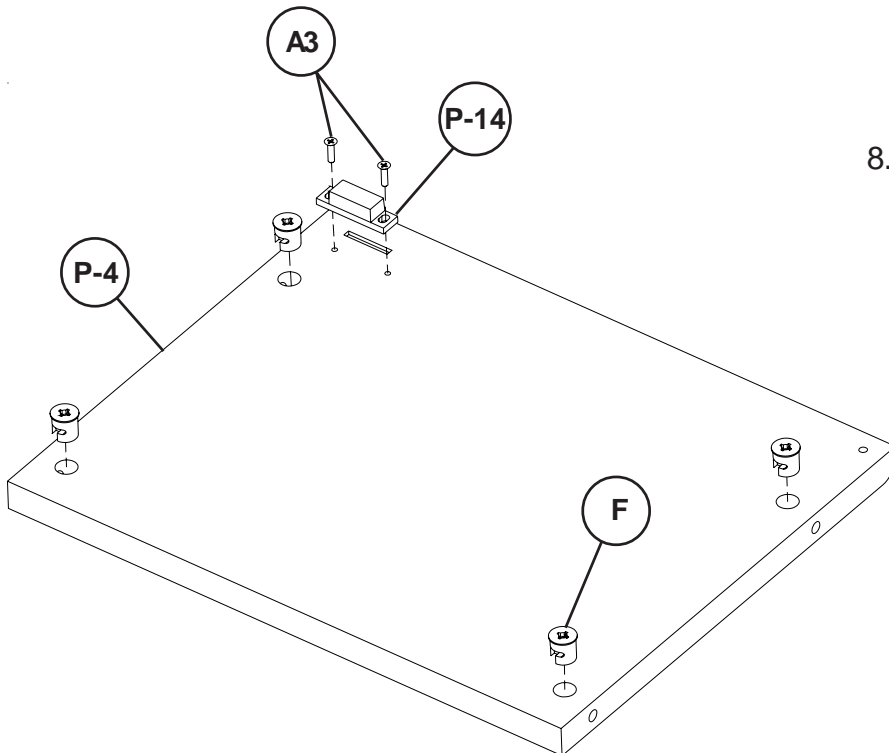
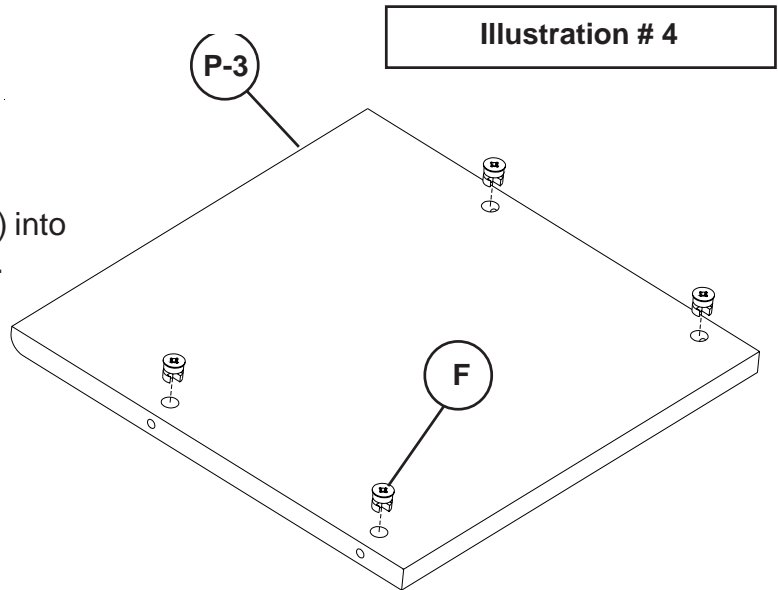

8. Place the Top Panel (P-4) with the Holes facing up and install 4 each Cam Locks (F) into the large holes as shown in illustration # 5.

9. Attach 1 each Door Magnet (P-14) to the Top Panel (P-4) and secure using 2 Wood Screws (A3) as shown in illustration # 5.

Illustration # 6

10. Place the Bottom Platform (P-5) with the Pre-drilled holes facing up and install 4 each Cam Posts (G) in the 4 threaded insert nuts (Pre-installed) as shown in illustration # 6.

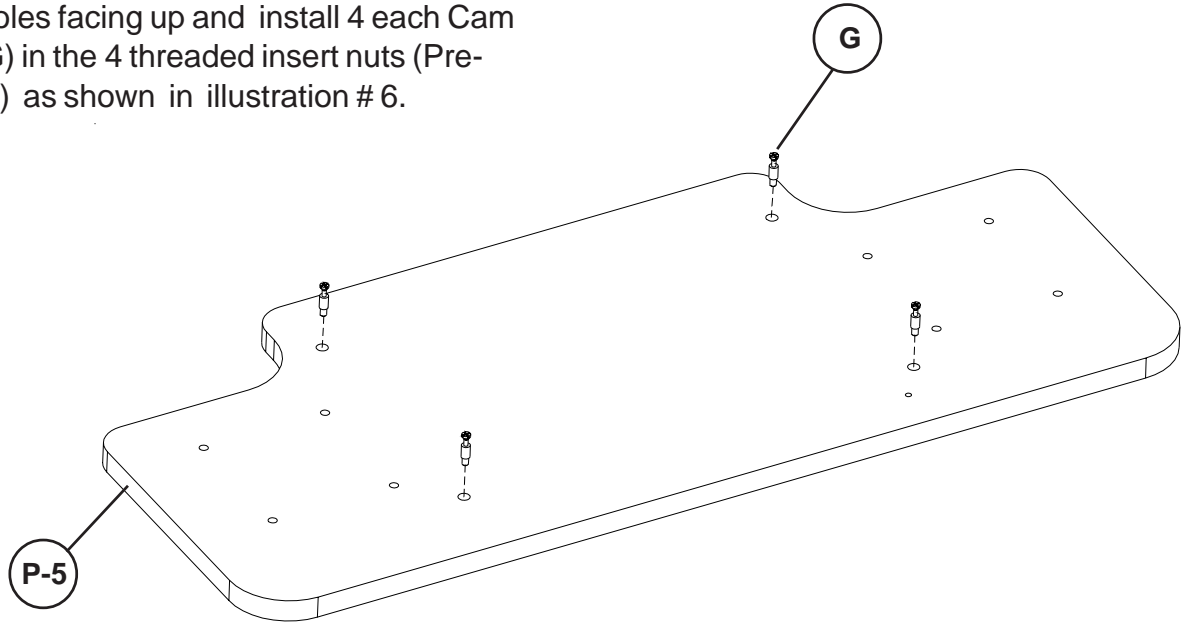

11. Attach Side Panels (P-1 & P-2) to the Back Panel (P-3) and the Top Panel (P-4) as shown in illustration # 7. Secure by turning the Cam Locks (F) 1/4" Turn until they lock.

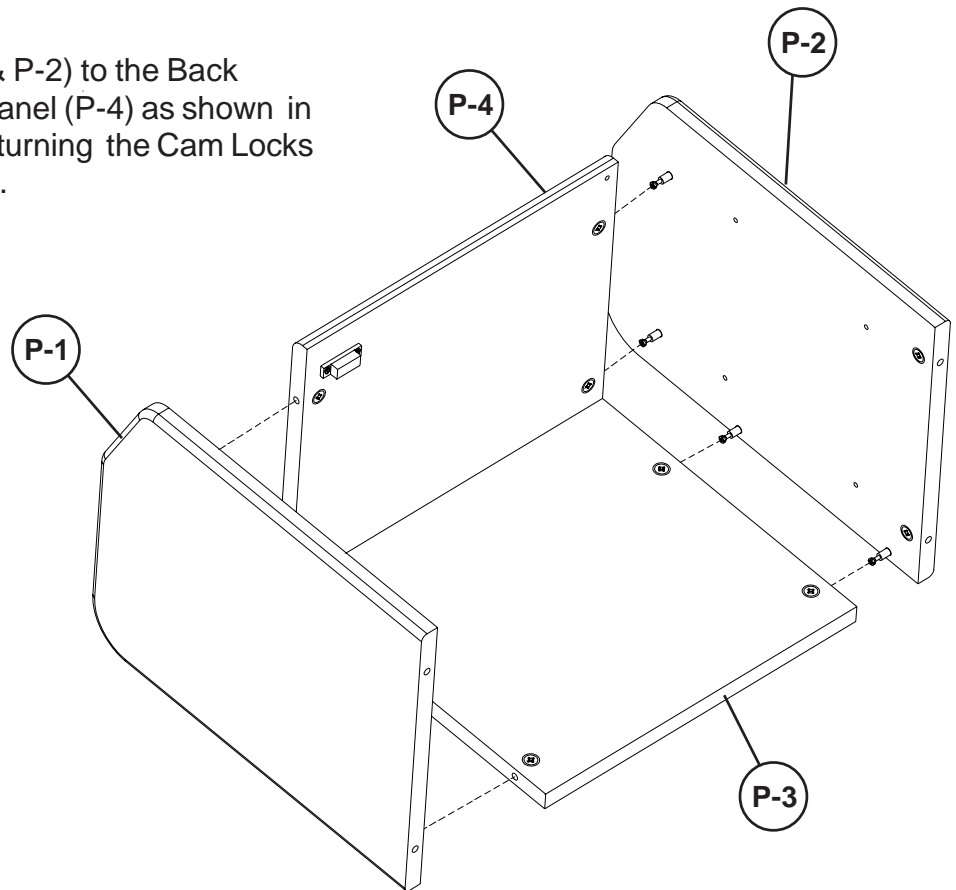
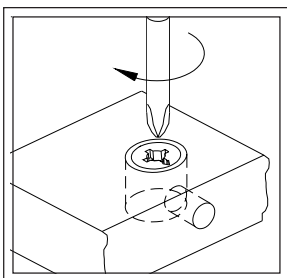

Illustration # 7



To Secure Cam Locks, Insert Large Phillips Head Screwdriver and turn Cam Lock 1/4 turn (90 degrees) clockwise.

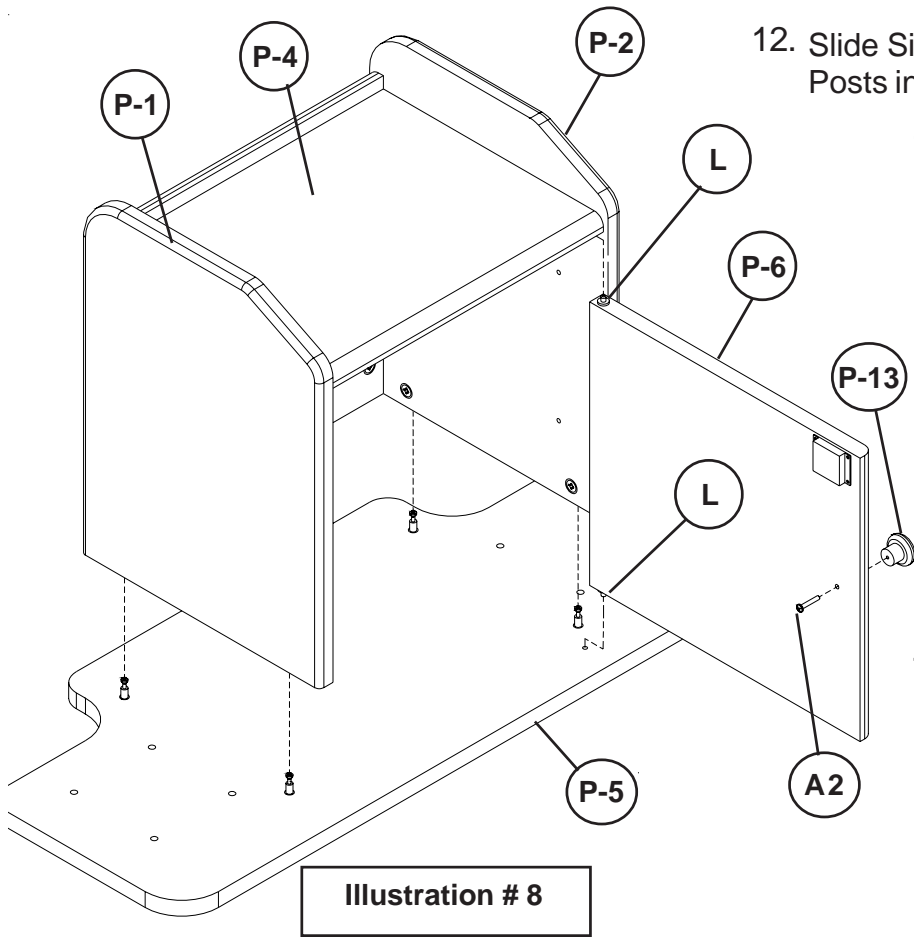

Illustration # 8

12. Slide Side Panels (P-1 & P-2) over Cam Posts in the Bottom Panel (P-5) .

13. Locate 2 each Spring Buttons (L) in the top and bottom of door (P-6).

14. Insert the end of Spring Buttons (L) into the holes in Top Panel (P-4) and Bottom Platform (P-5) as shown in illustration # 8.

15. Secure Cabinet assembly to Bottom Panel (P-5) by turning the Cam Locks (F) 1/4 Turn until they lock.

16. Attach Door Knob (P-13) to Door (P-6) using 1 each (A-2) screw.

17. Attach the Short Column (P-9) to the Bottom Platform (P-5) and to the Base (P-8) using 4 each long screws (A1) as shown in illustration # 9. (Finger tighten only.)

18. Attach the Tall Column (P-10) to the Bottom Platform (P-5) and to the Base (P-8) using 4 each long screws (A1) as shown in illustration # 9. (Finger tighten only.)

19. Attach 2 Locking Casters (D) to the front, and 2 Casters (E) to the back of the unit. Tighten all Casters using Caster Wrench (J).

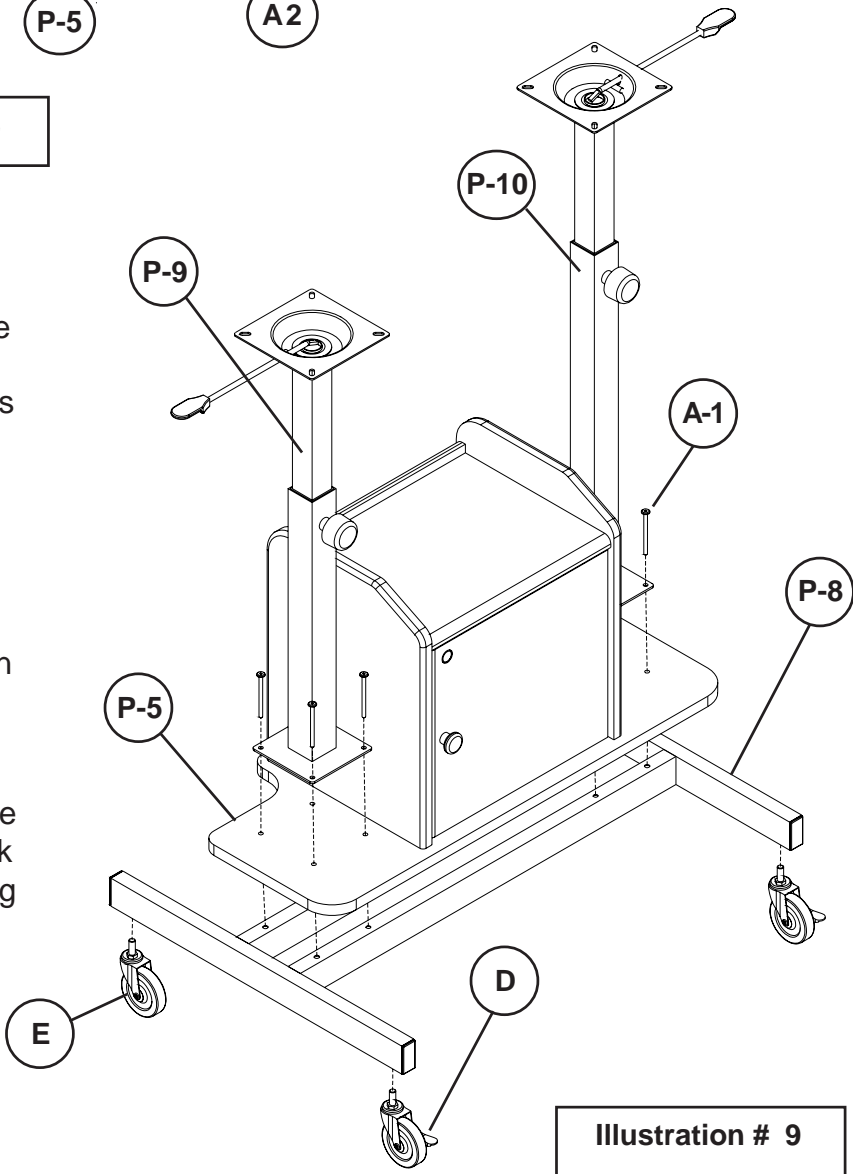

Illustration # 9

20. Attach LCD Platform (P-12) to the tall Column (P-10) using 4 each short screws (A) and 4 each Flat Washers (M) as shown in illustration # 10. (*Finger tighten only.*)

21. Attach Laptop Platform (P-11) to the short Column (P-9) using using 4 each short screws (A) and 4 each Flat Washers (M) as shown in illustration # 10. (*Finger tighten only.*)

22. Tighten all socket head screws using allen wrench (H).

Missing Parts or UPS Damaged Parts
For Your Convenience you can
EMAIL us at
furniture@baltinc.com
24HOURS 7 DAYS A WEEK

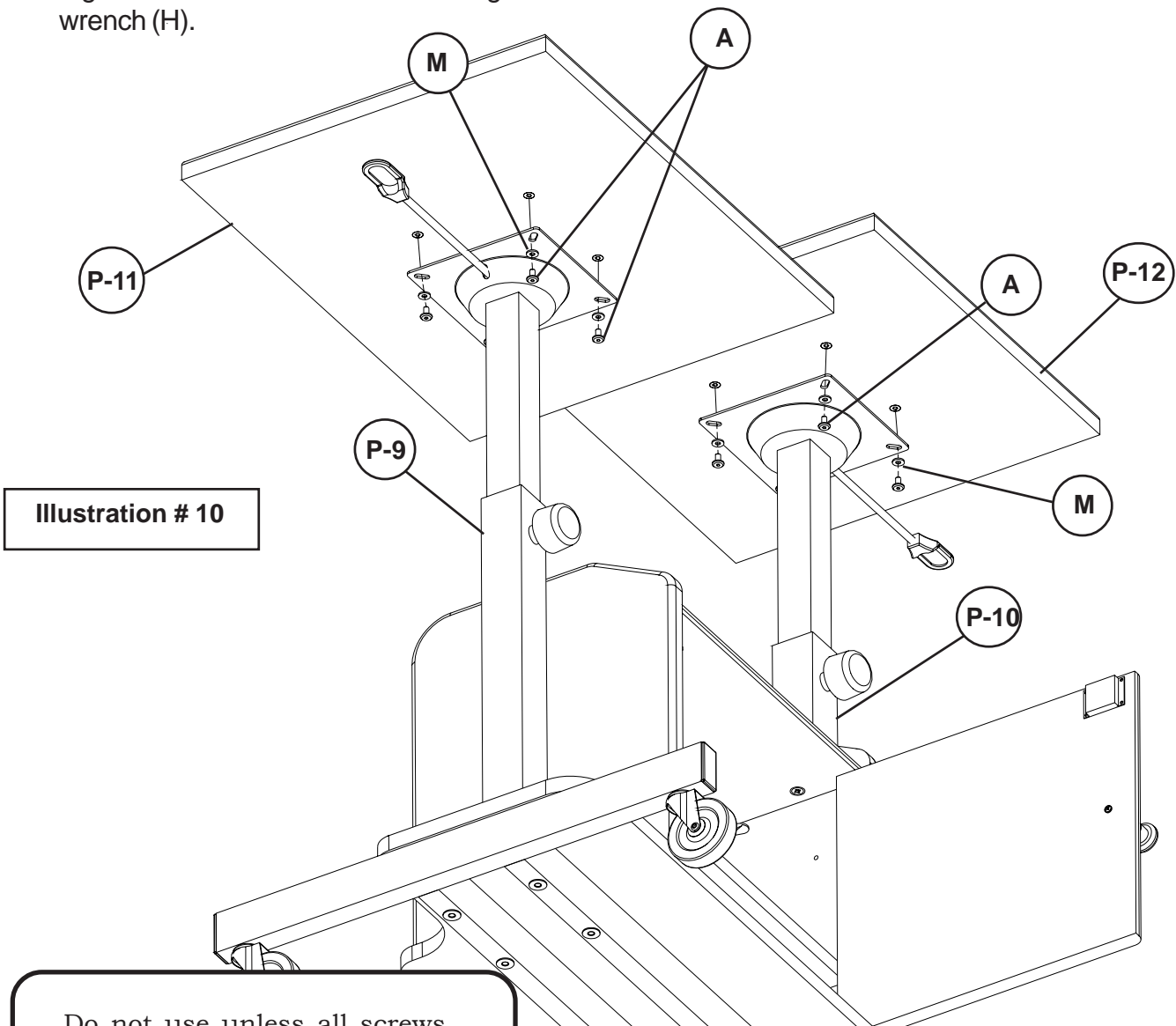

Do not use unless all screws are tight. At least every six months, check all screws to be sure they are tight. If parts are missing, broken, damaged, or worn, stop use of the product until repairs are made by your dealer using factory authorized parts.

**Should you require assistance during assembly,
please call our Customer Service Department
Monday - Friday 8 a.m. - 5 p.m.
Central Standard Time
Toll-Free Customer Service
1-800-749-2258**

Illustration # 11

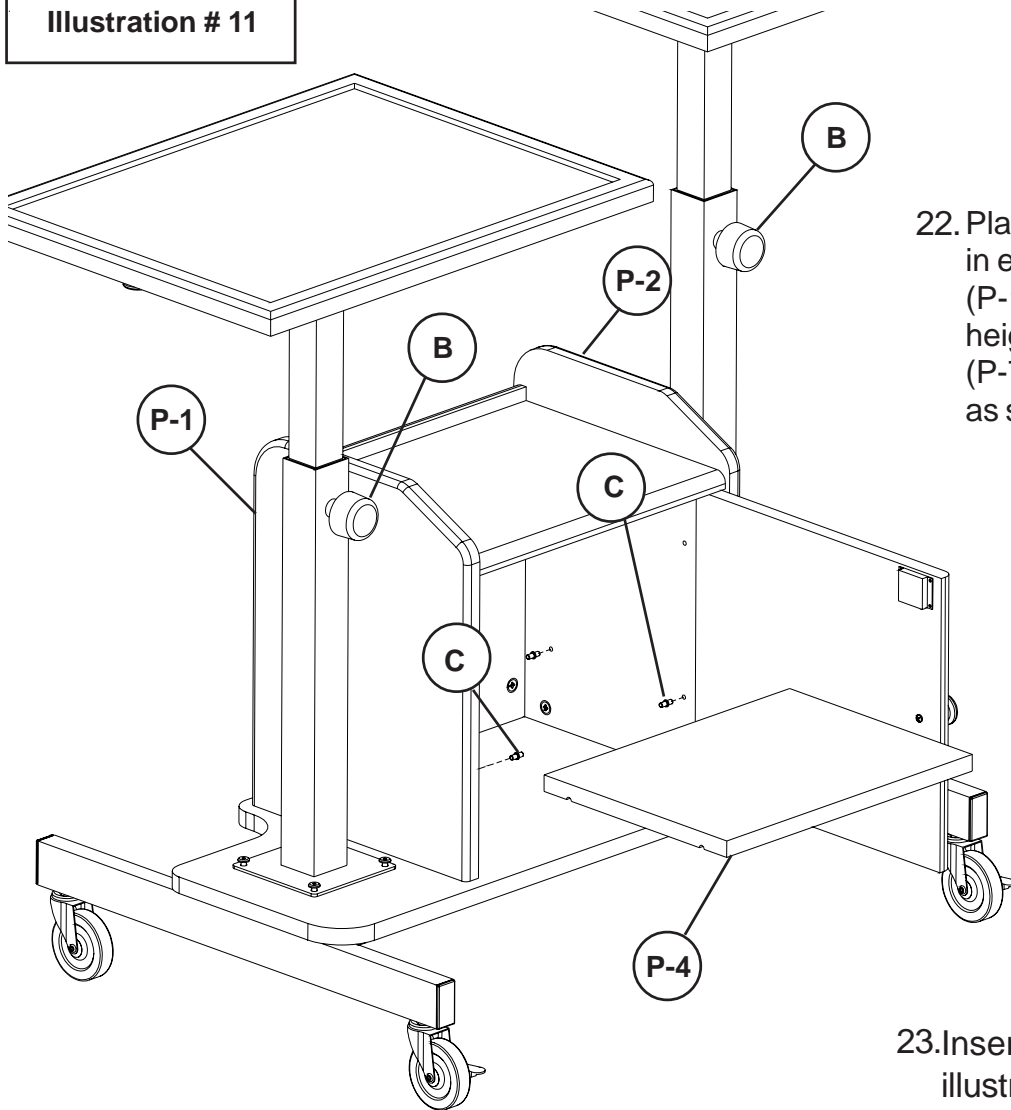

22. Place 4 Shelf Support Pins (C) in each of the two Side Panels (P-1 & P-2) at desired shelf height. Place Removable Shelf (P-7) on four Shelf Support Pins as shown in illustration #11.

Height Adjustment

To raise height of either platform, loosen adjustment knob (B) and press handle on height adjustment bracket upward toward top. The pneumatic cylinder will begin lifting the unit, and you can release handle at the desired height. Secure platform at desired height by tightening adjustment knob (B).

To lower height of either platform, loosen adjustment knob (B) and press handle on height adjustment bracket upward toward top. Press on center of Top Platform using body weight. Top Platform will lower and you can release handle at the desired height. Secure platform at desired height by tightening adjustment knob (B).

23. Insert Key (K) as shown in illustration # 12 and turn lock counter-clockwise to lock door.

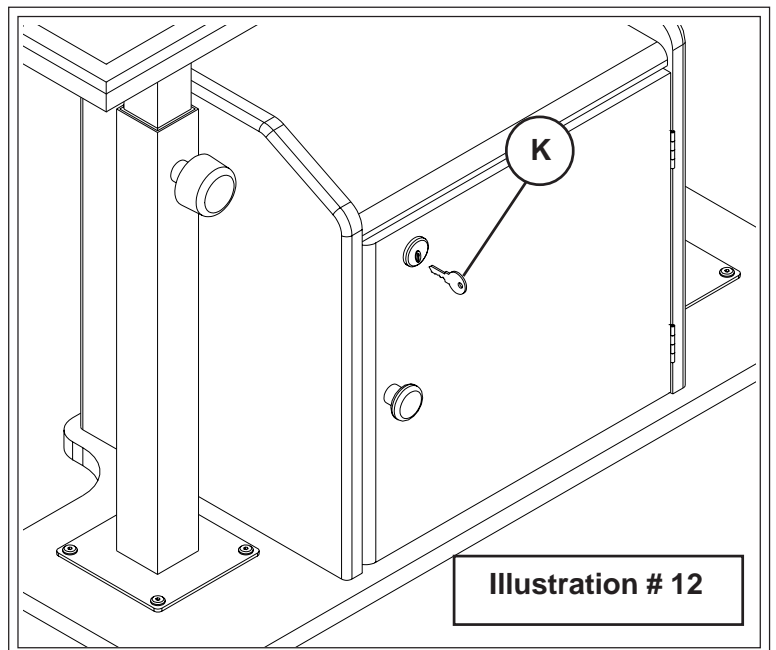
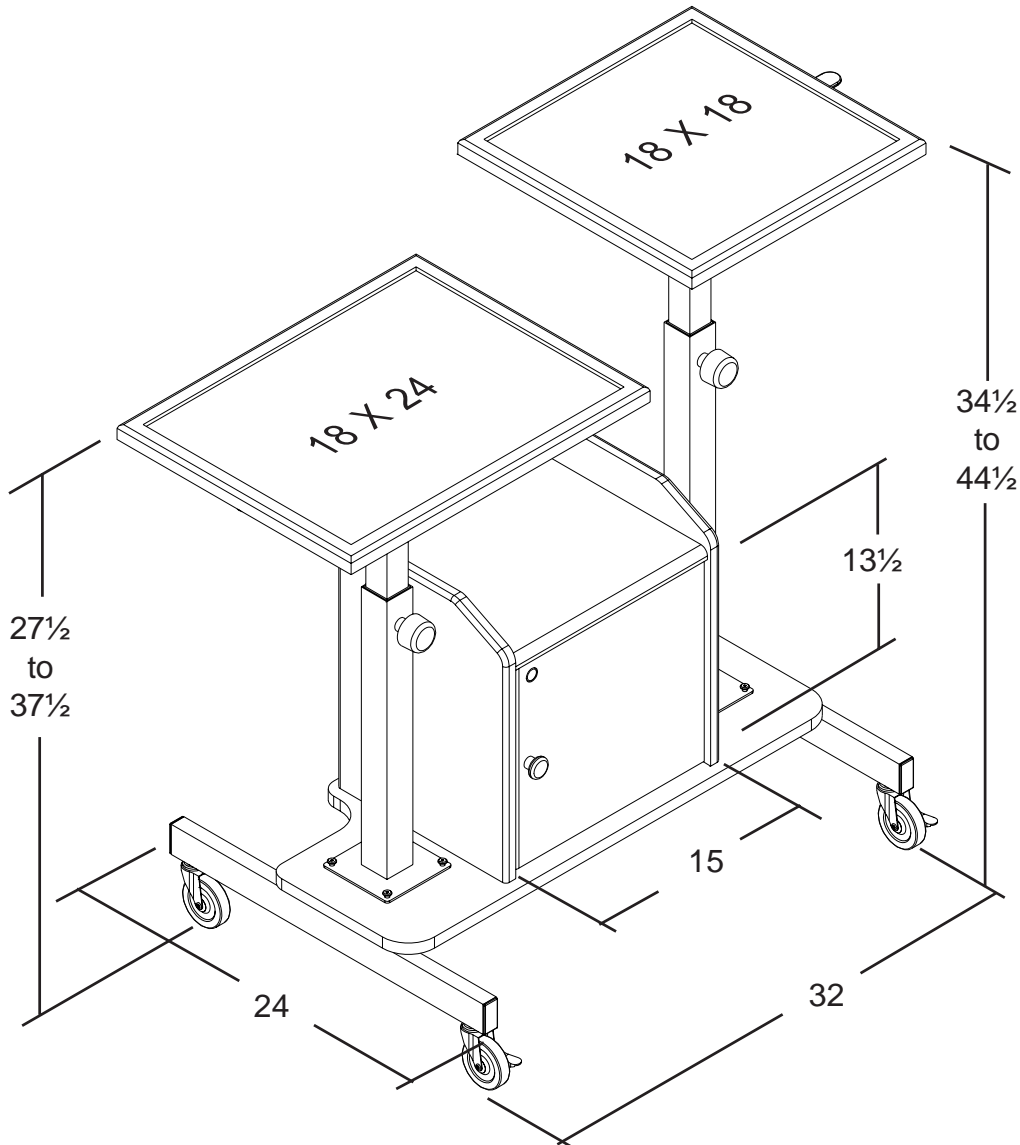

Illustration # 12

#82692 ProView Adjustable Height Presentation Stand



For more information
1-800-749-2258



Shipping Information
4.8 Cubic Feet
95 lbs.

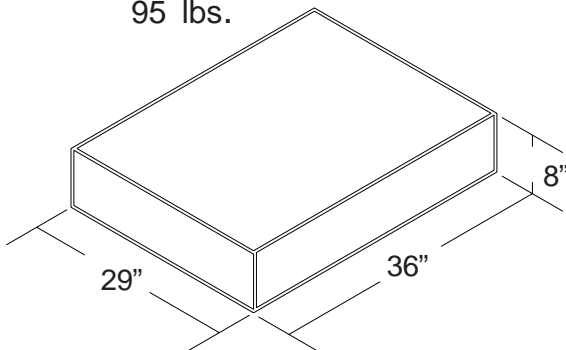

Features 2 independent pneumatically adjustable worksurfaces.(1 for Laptop & 1 for LCD Projector)

Locking Security Cabinet to protect valuable presentation equipment.(inside dimensions 15"W X 13"D X 13 1/2"H)

Includes 3" Casters for mobility.

Available in Black Vacuum formed MDF.

Ships UPS.