

Dual HD With Keyboard

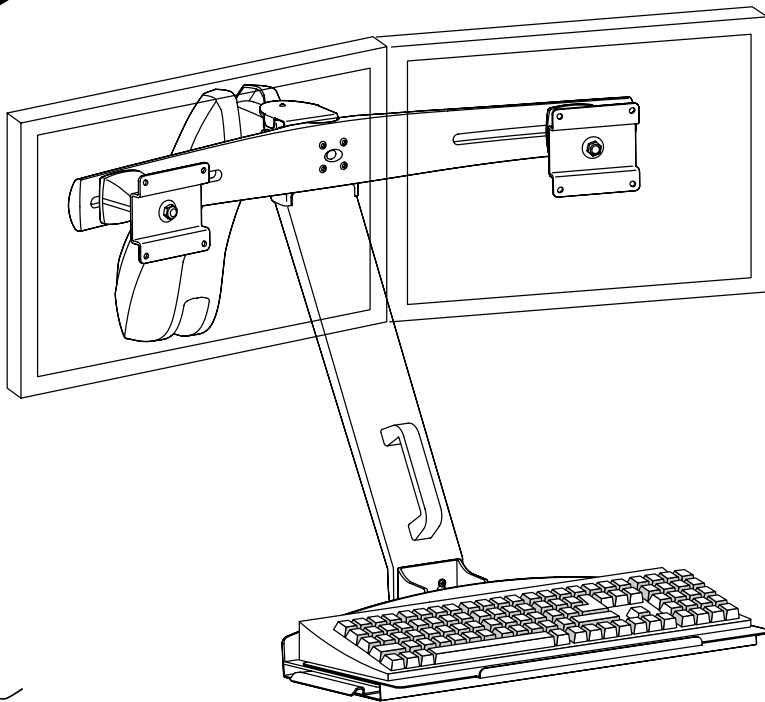

USA 1-800-888-8458
Europe +31 (0)33-45 45 600



	A	B	C	D	E
1	1x	2x	1x	2x 75-100mm	 M4 x 10 mm #8-32 M4 x 10 mm 3/32"
2	1x		1x	1x	4x 10-24 x 5/8"
				4x	4x 10-32 x 3/8"
3	1x		1x		4x 8-32 x 5/16"
					3x 6-32 x 3/8"
4	2x				1x 1/8"
					1x 1/2"

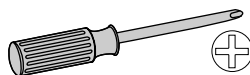
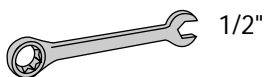
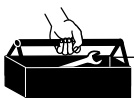

1 Determine Ergonomic Mounting Height

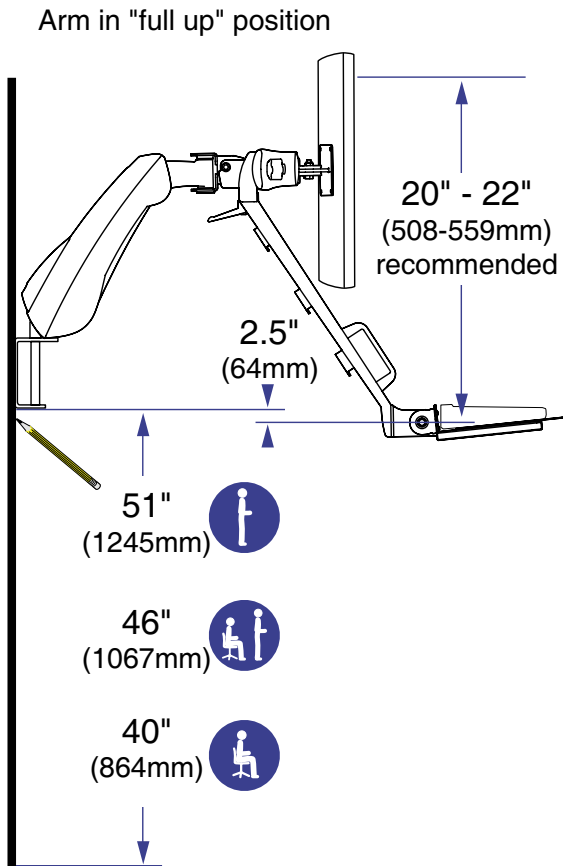

HD Extender Arm

NOTE: Mounting Height does not change if mounted to an HD Extender Arm.

Mounting Height

2 Mount arm to support or base

- vertical mount

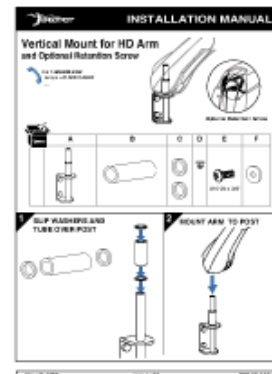
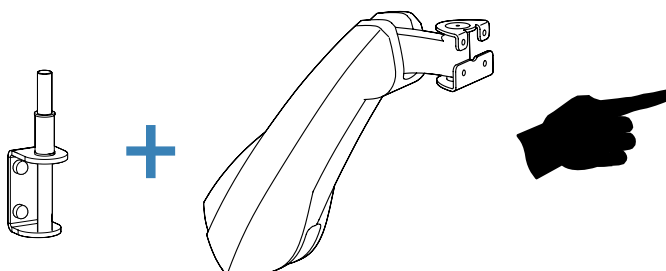

888-60-112

3

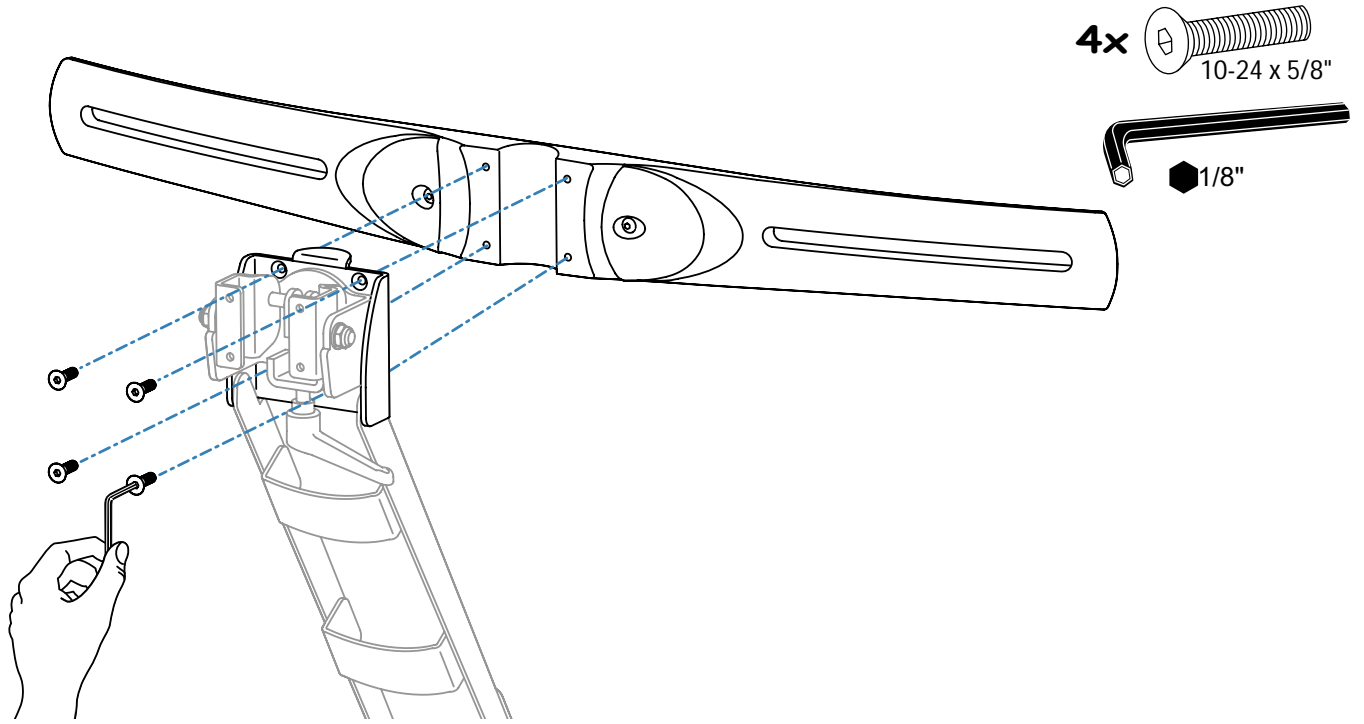

4
a

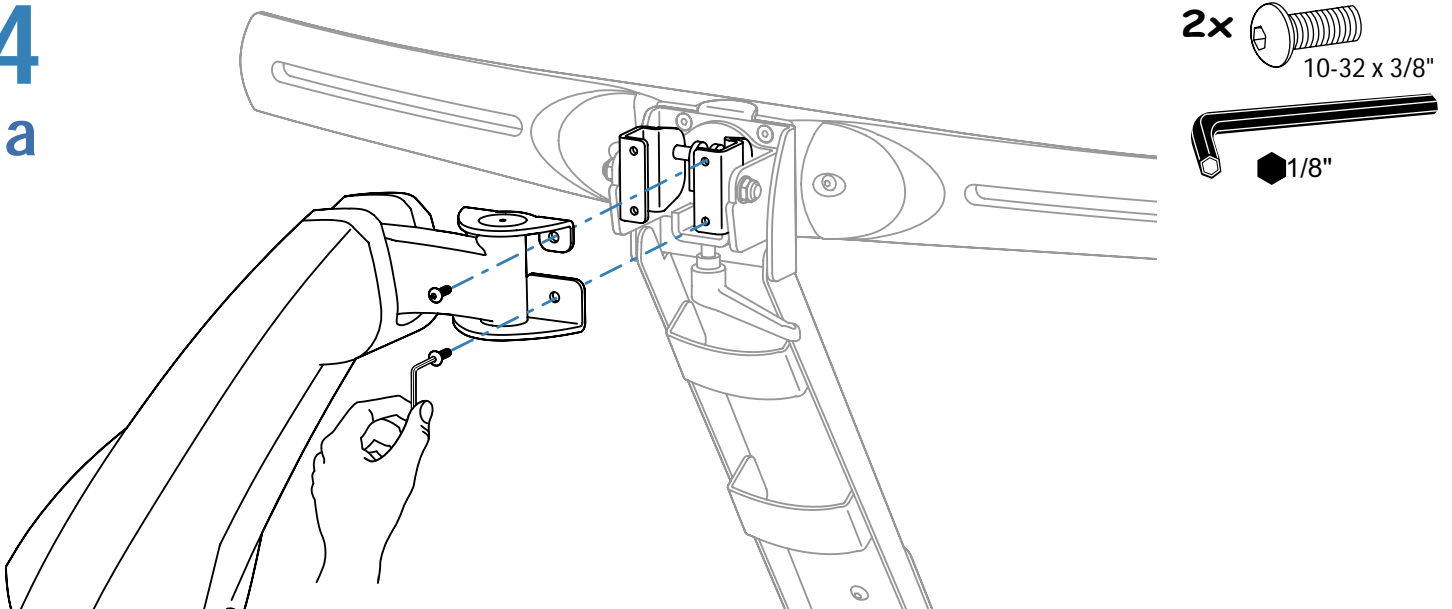

b

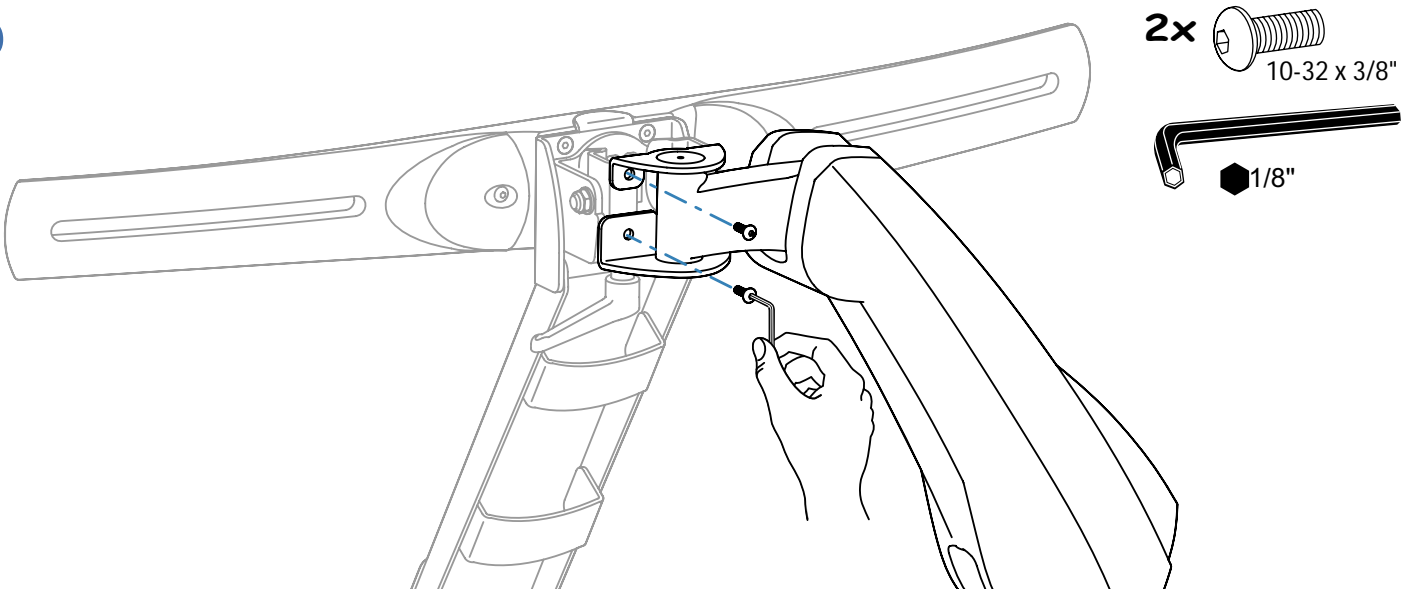

5

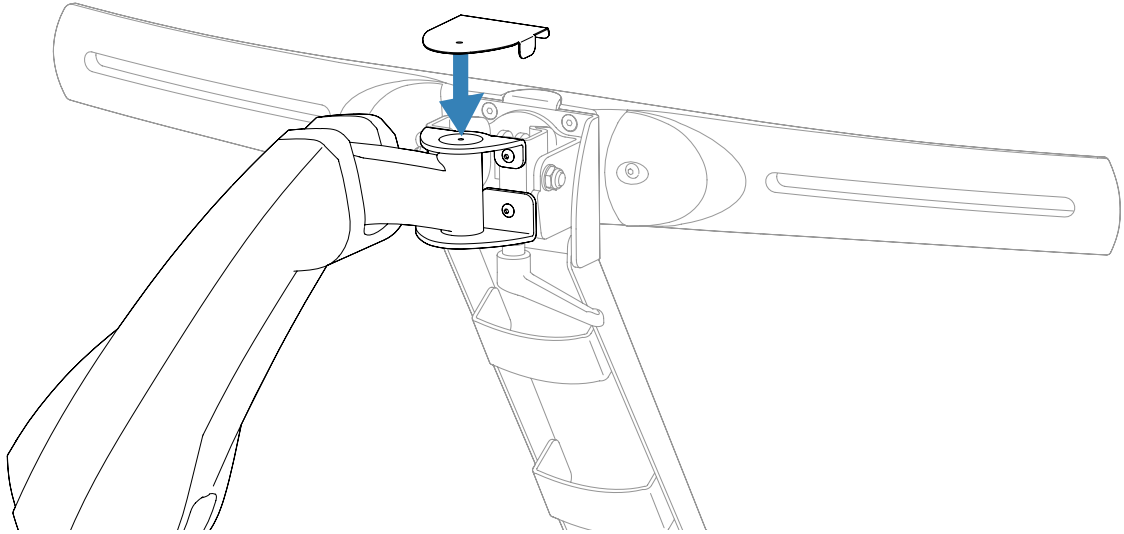

a

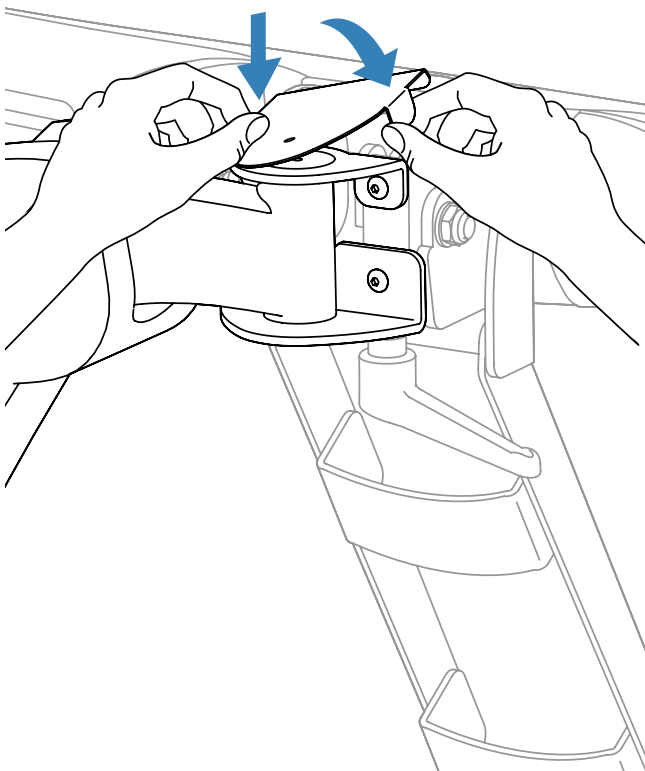

b

1x  6-32 x 3/8"

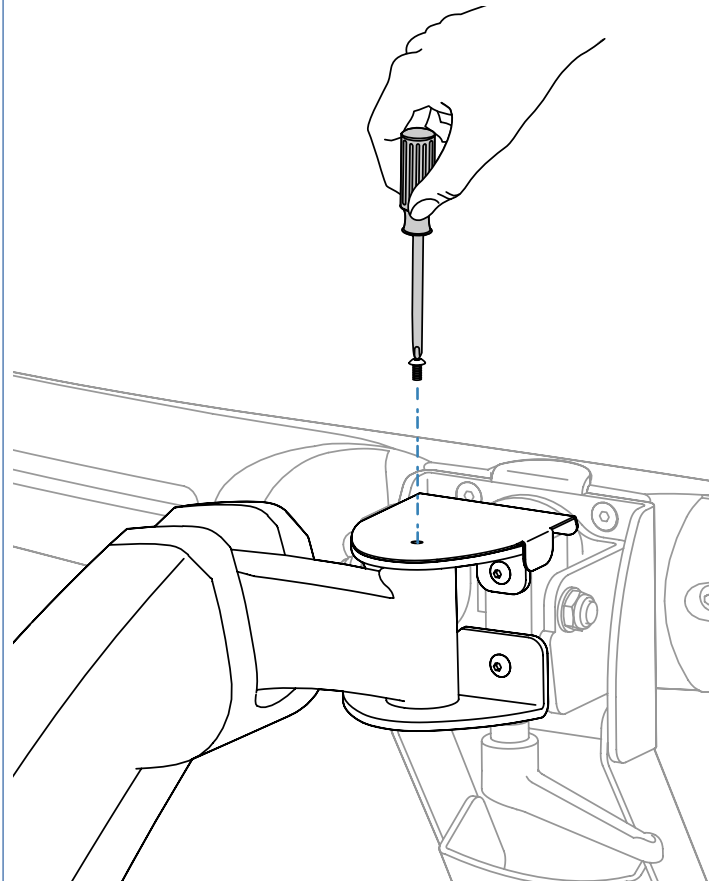
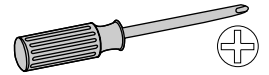

6

2x  8-32 x 5/16"

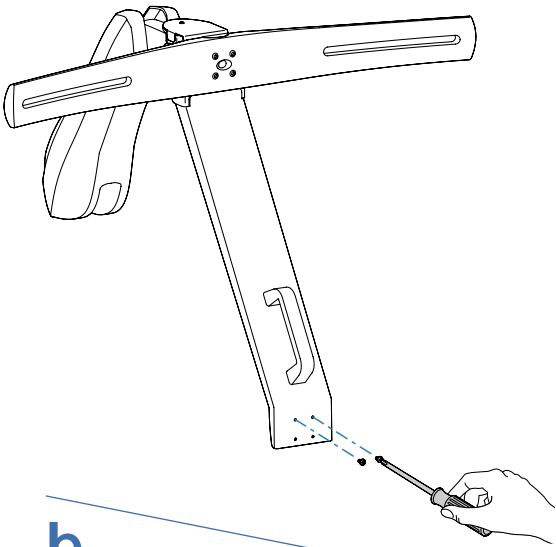

a

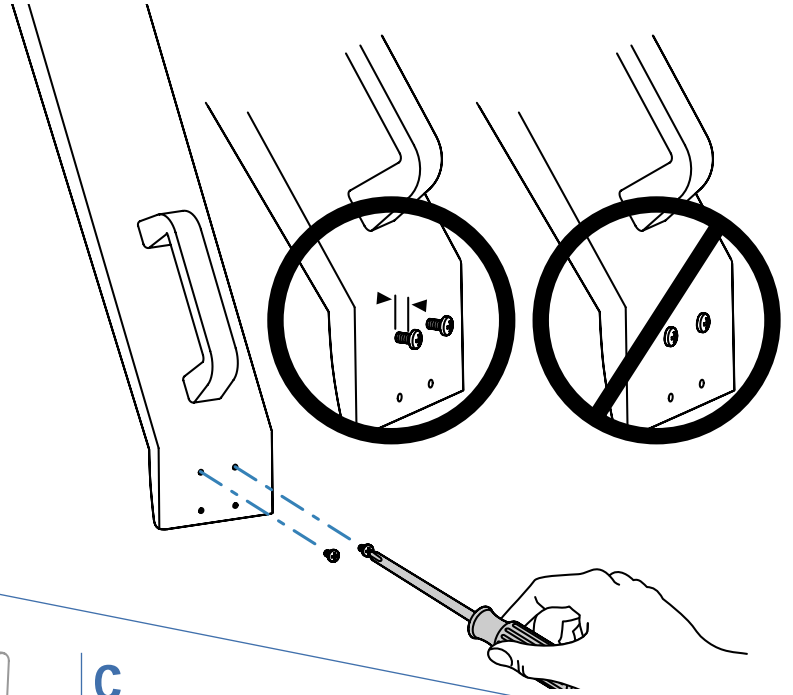

b

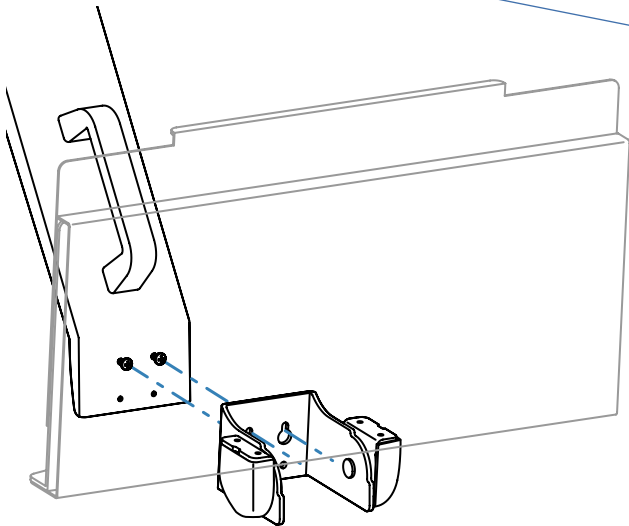

c

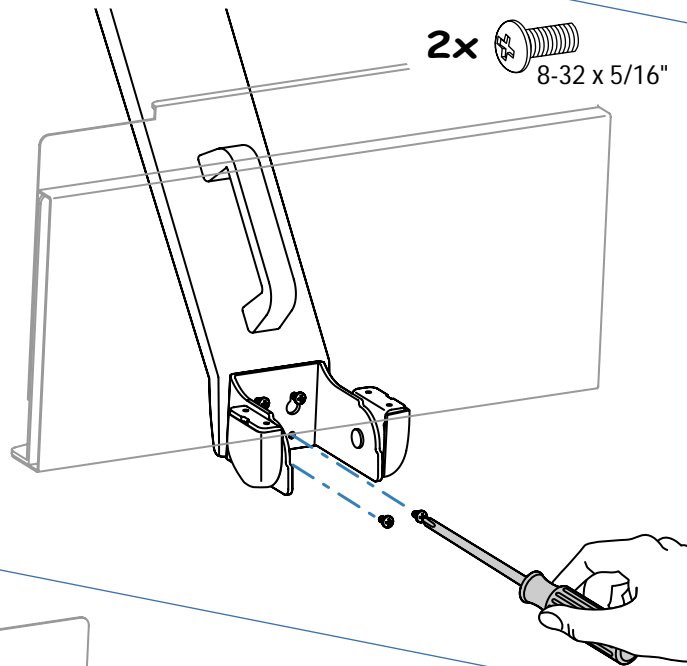

d

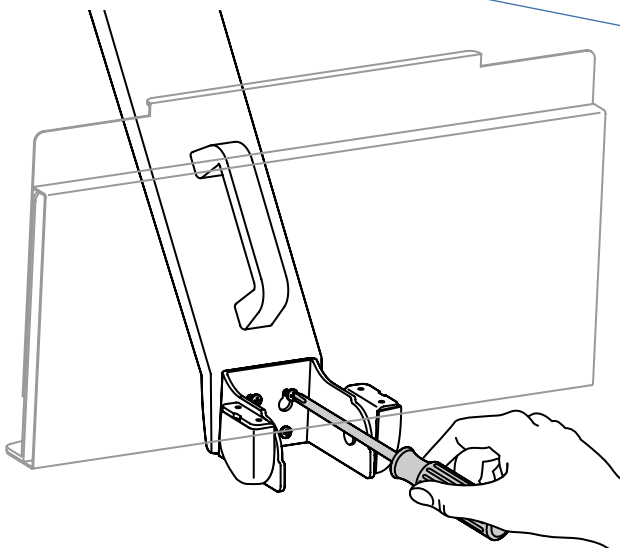

7
a

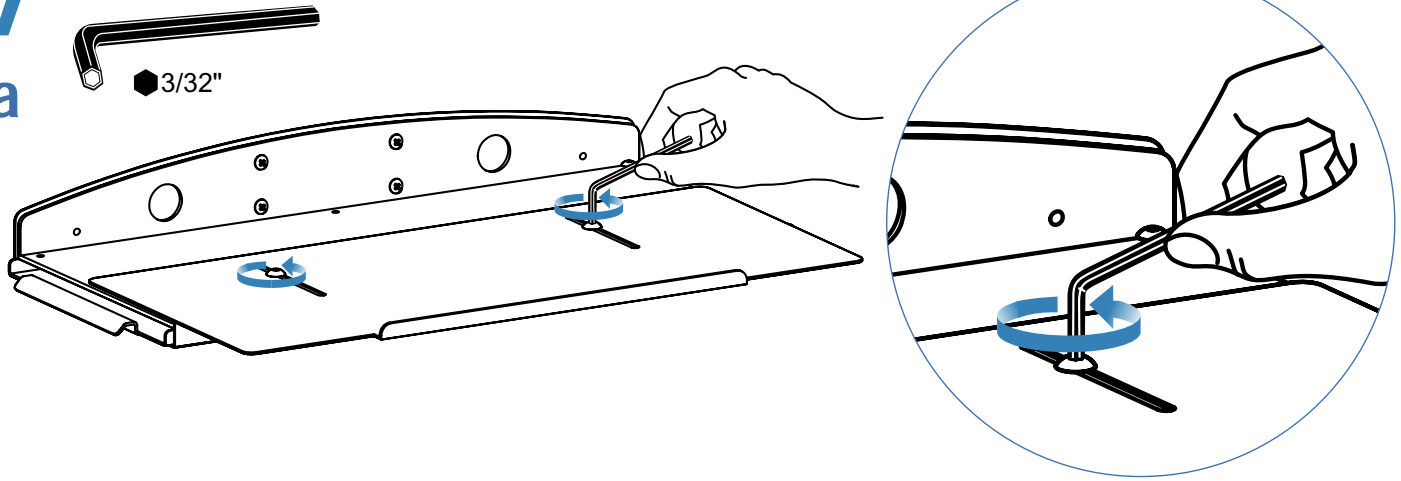

b

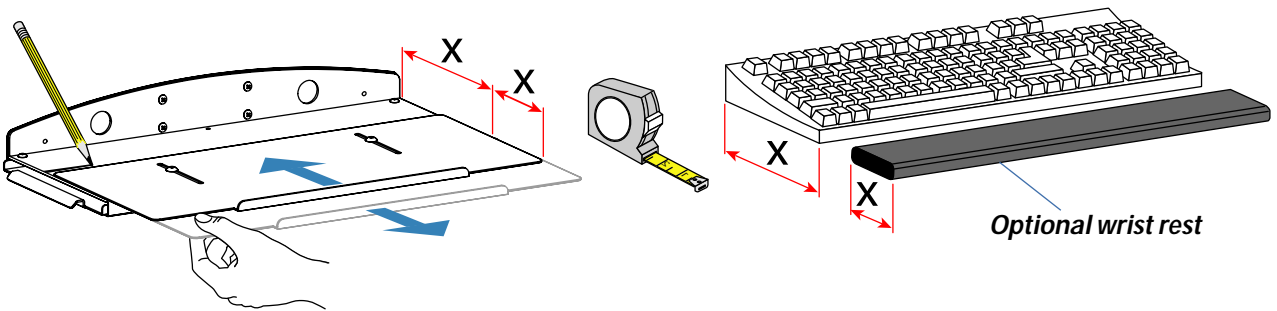

c

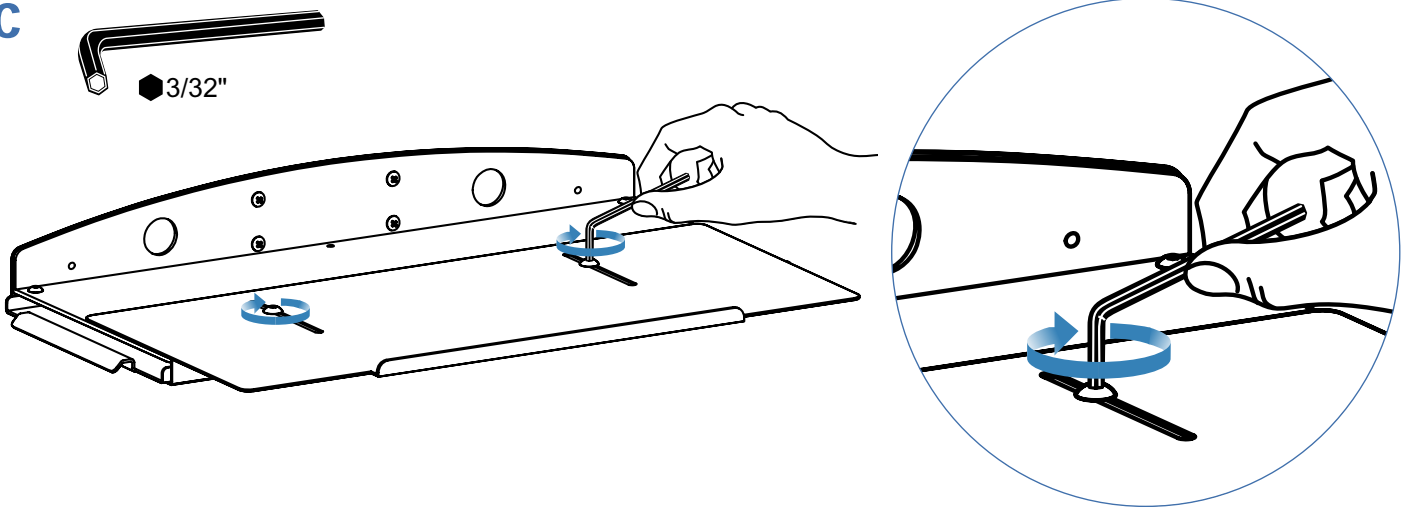

d

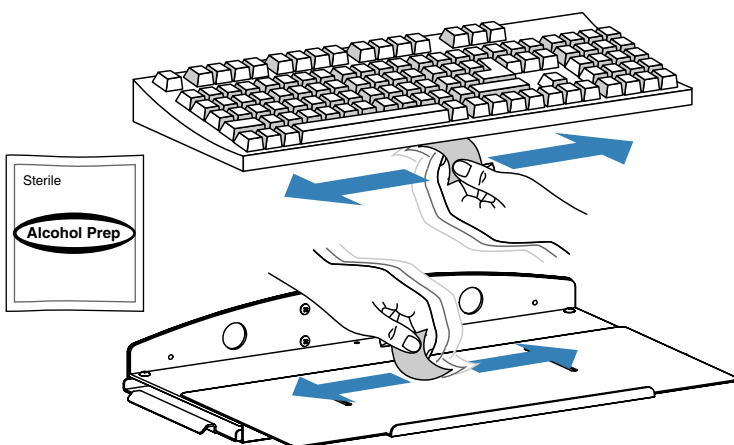

e

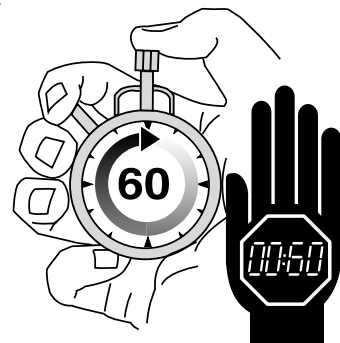

8

a

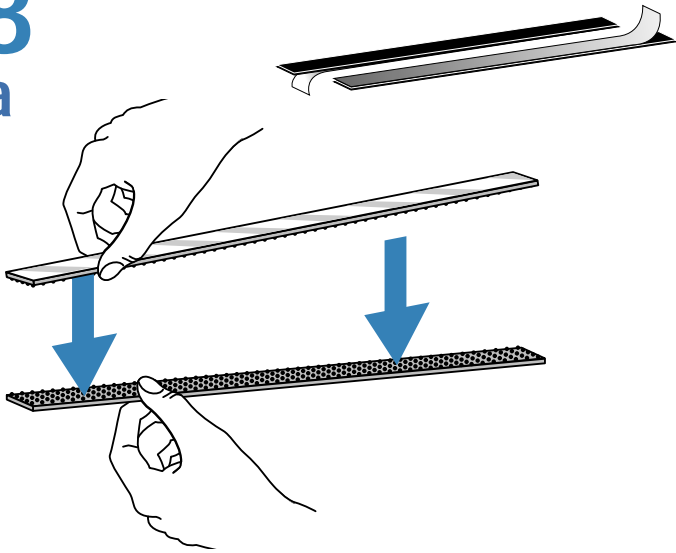

b

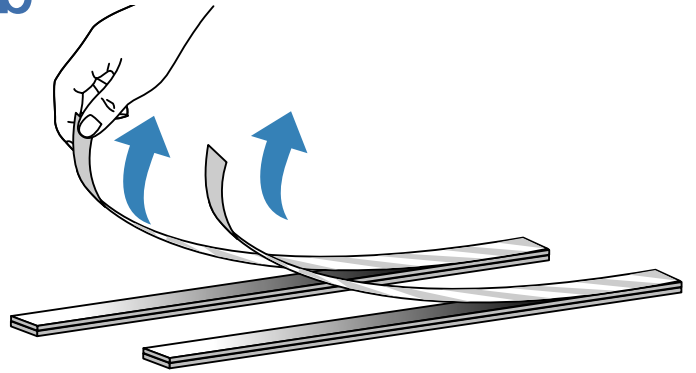

c

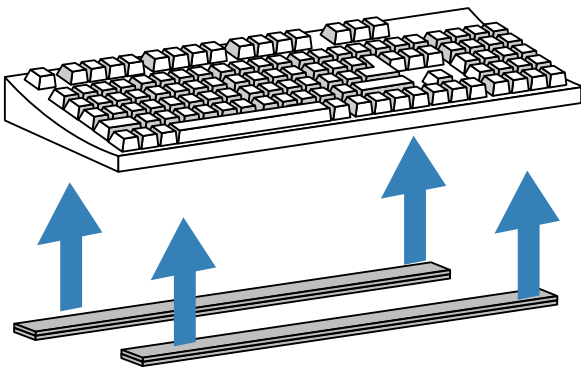

d

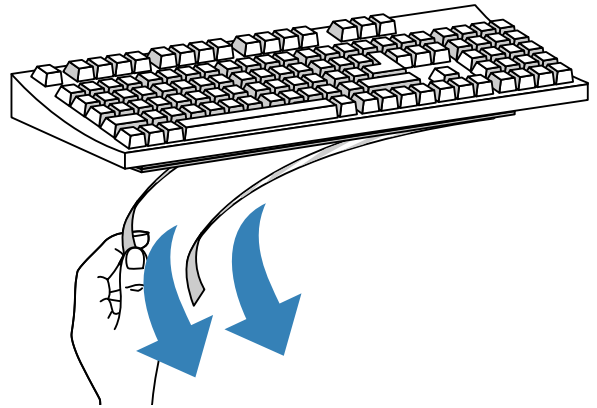

e

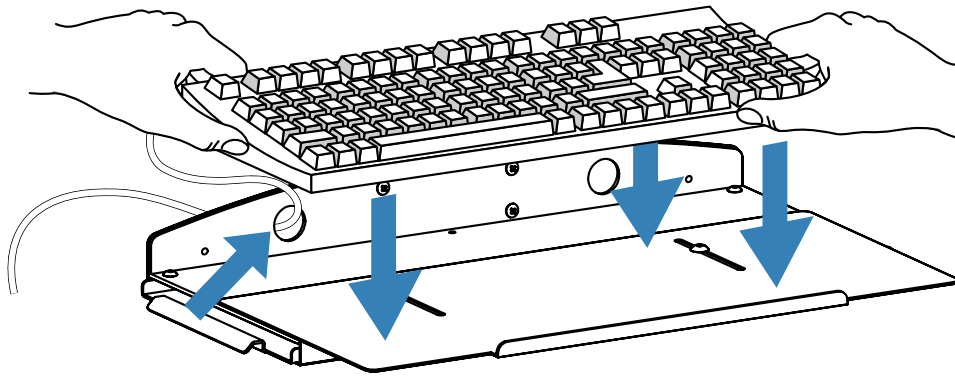

f

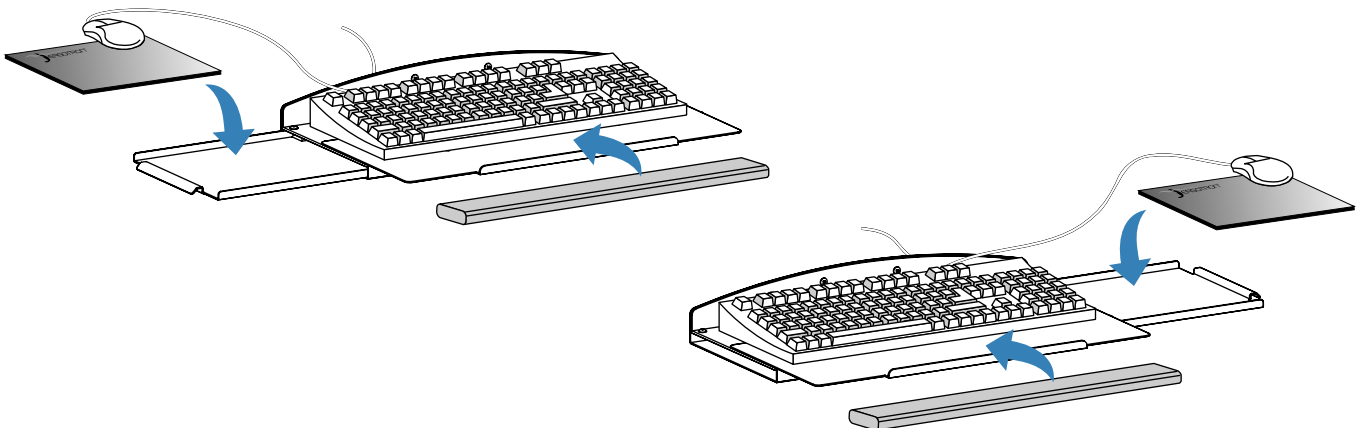

9

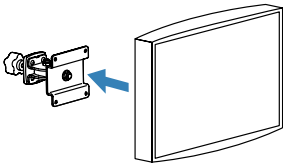

WARNING: To avoid damage to your monitor, if your monitor requires a screw size other than the M4 screws and knobs provided in this kit, use the screw size recommended by the monitor manufacturer!

75mm

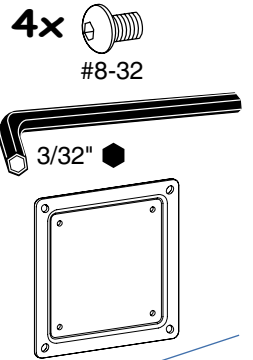
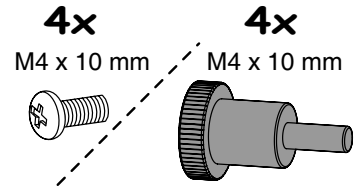
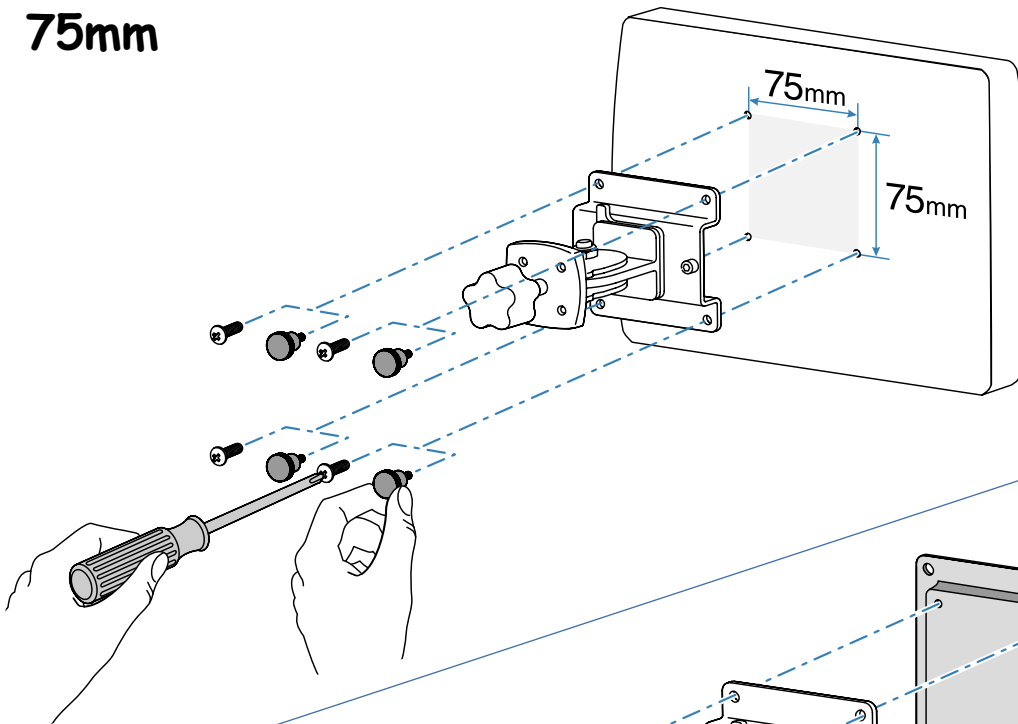

100mm

a

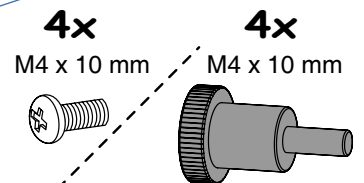
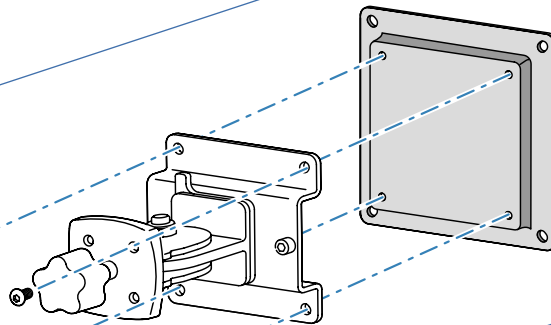
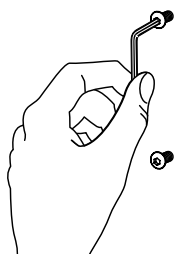

b

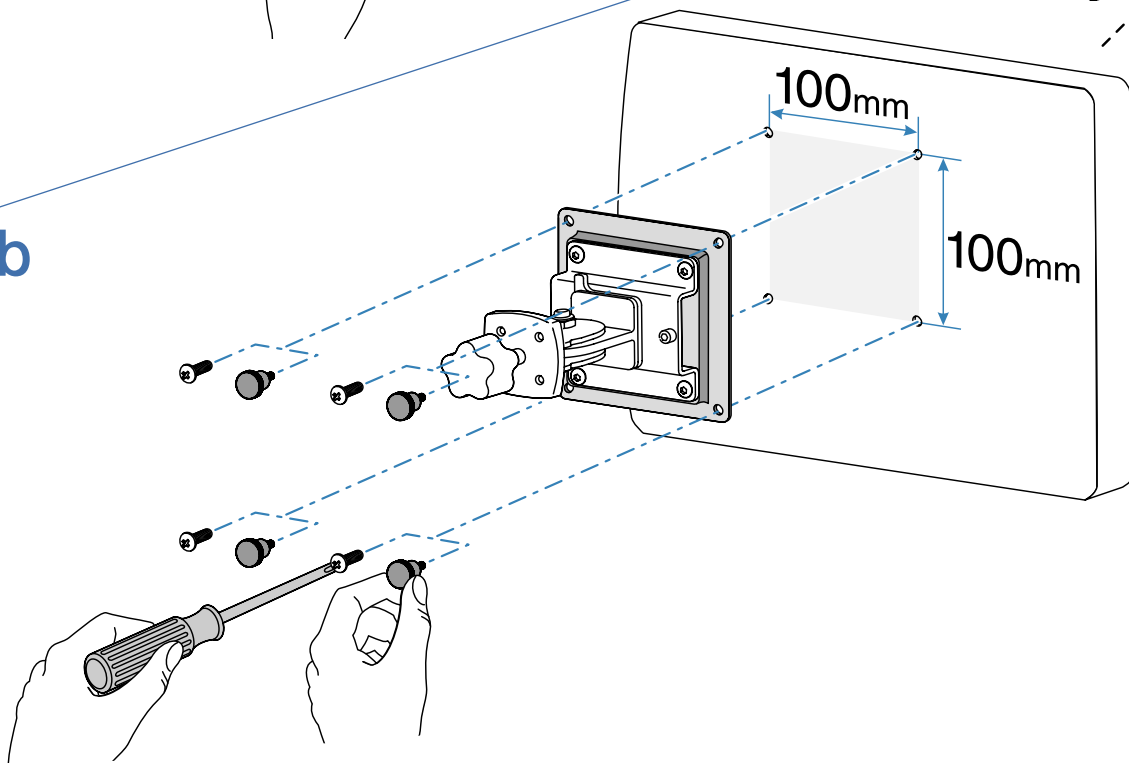

10

a

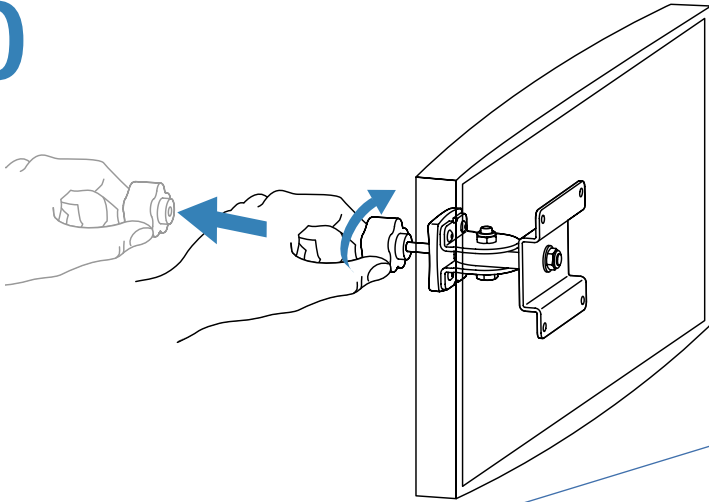

b

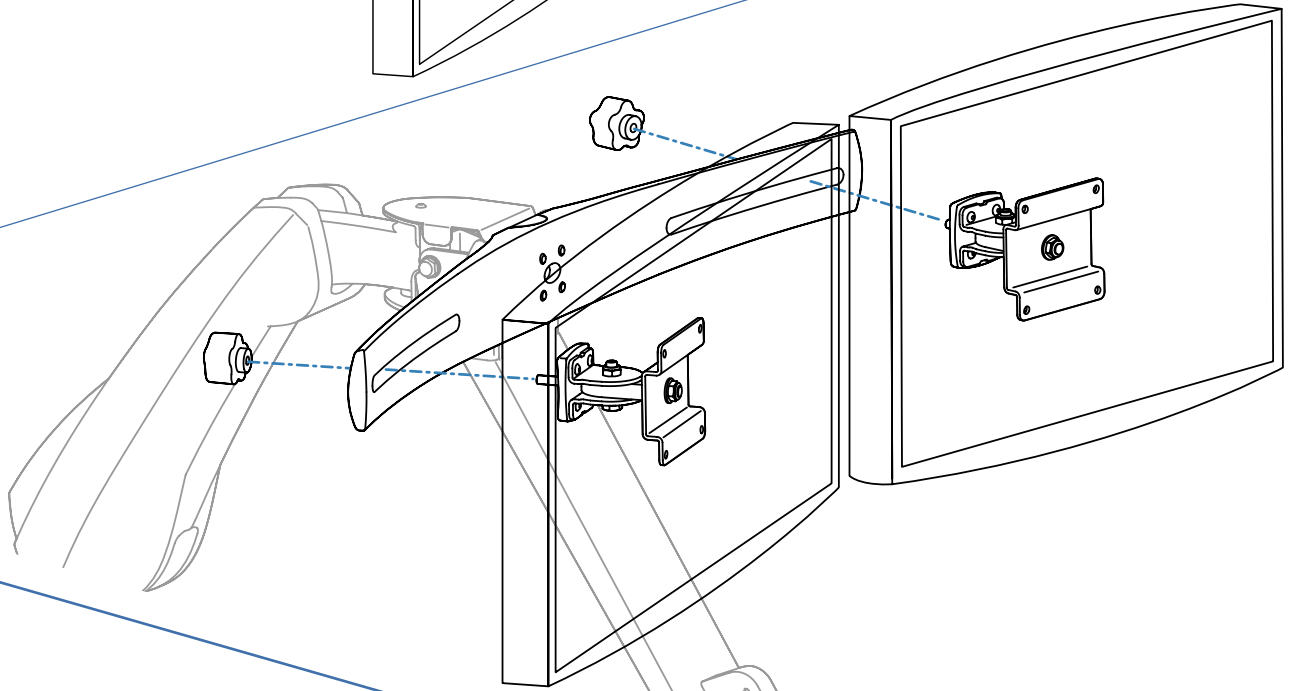

11

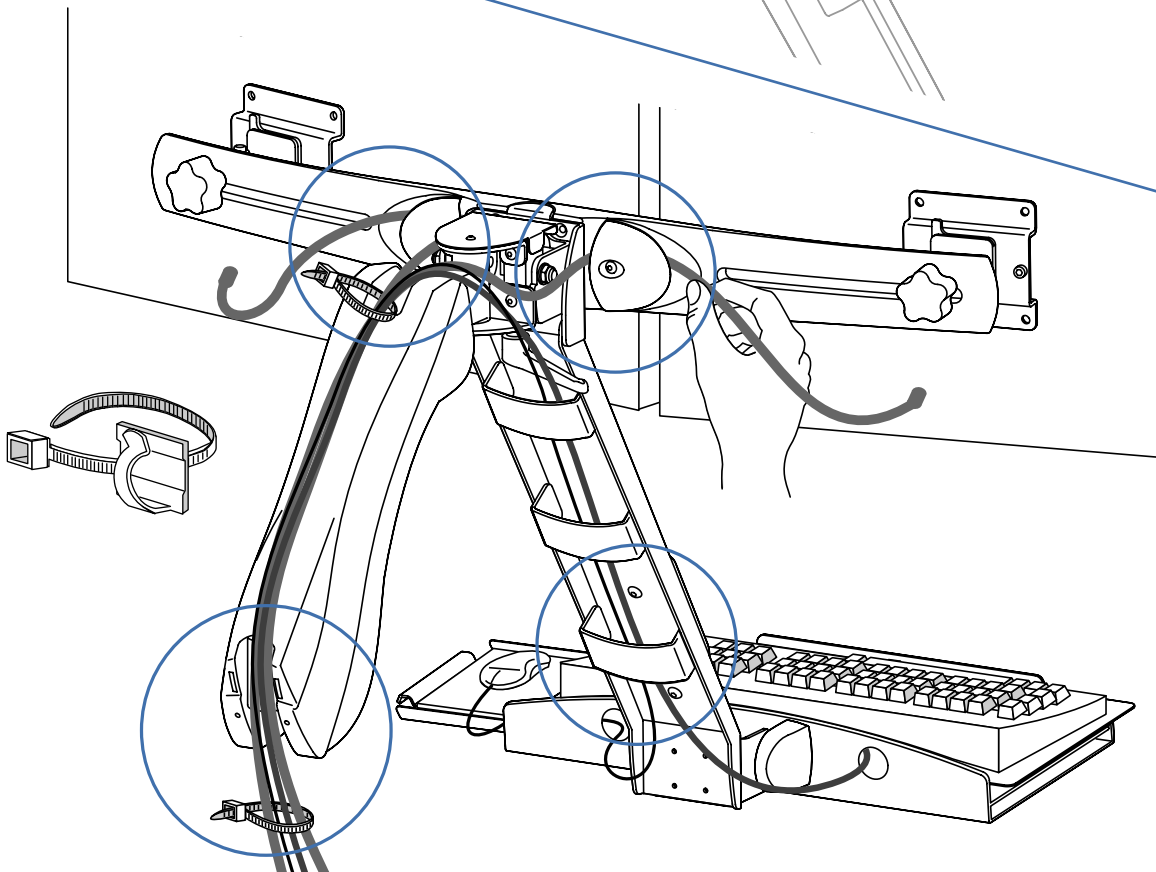

12

a

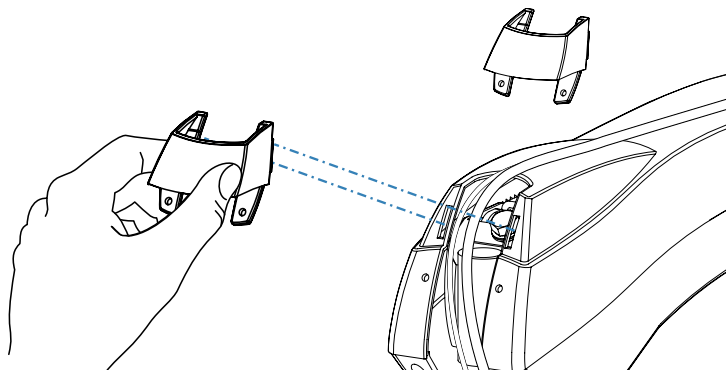

b

2x  6-32 x 3/8"

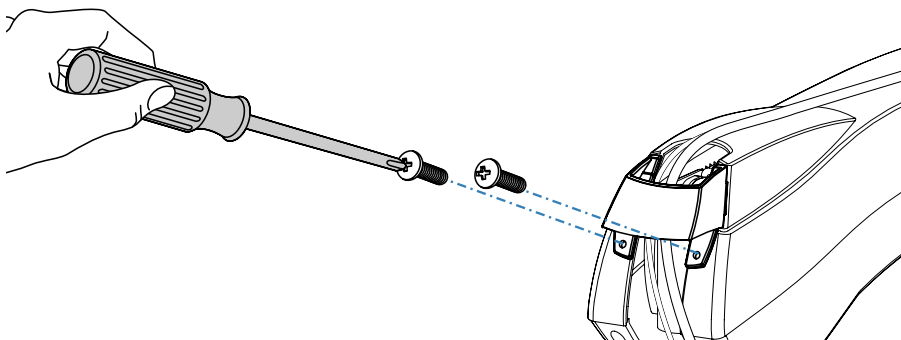

c

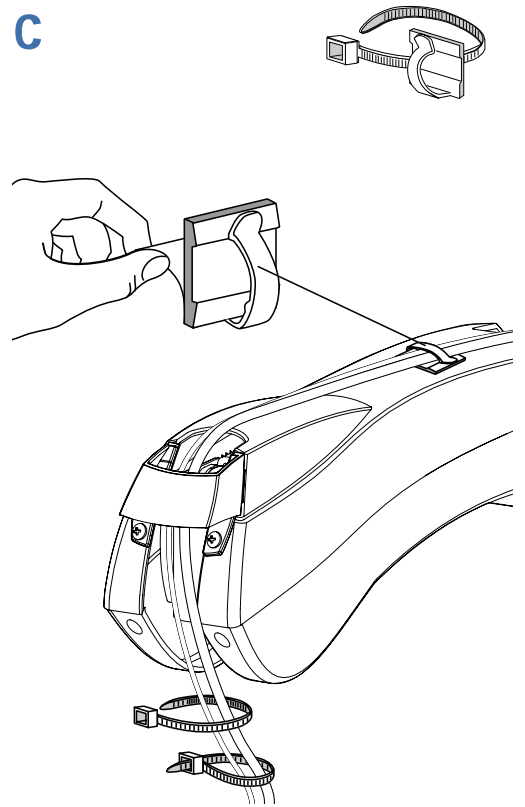

13 Adjustment

a Lift the arm up and down through its entire range of motion and follow adjustment steps below if necessary.

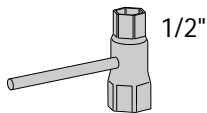

ii

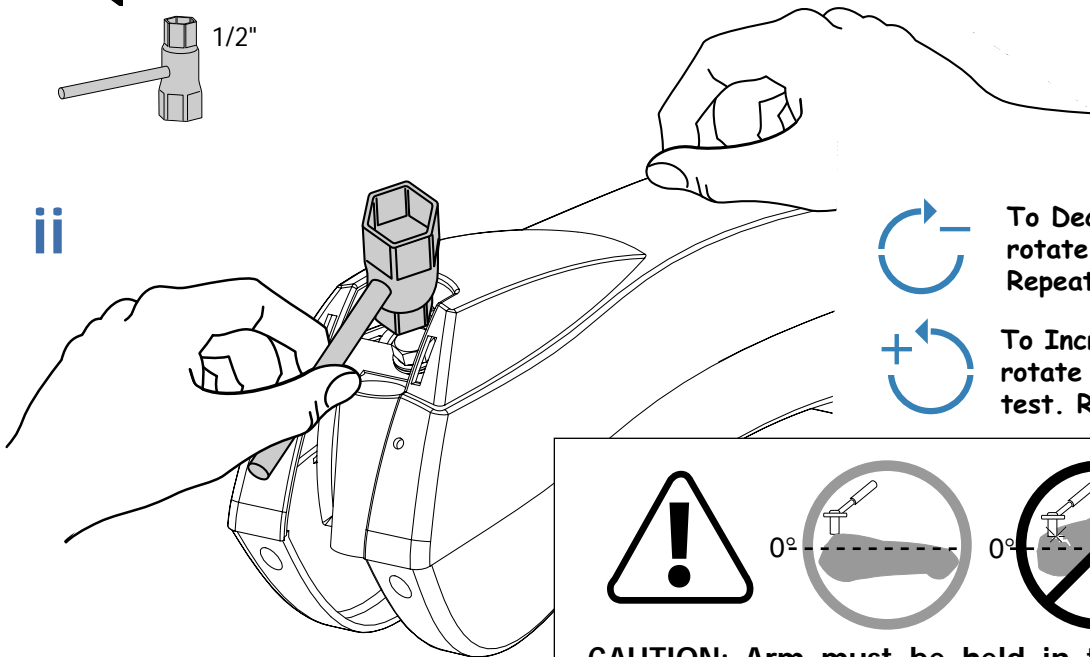

i

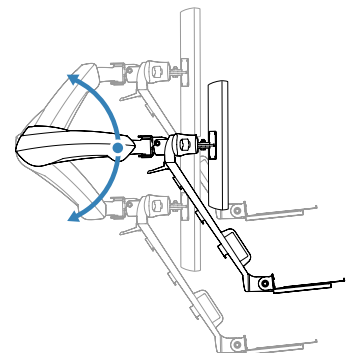

To Decrease Lifting Force of Arm: rotate nut clockwise and test. Repeat as necessary.



To Increase Lifting Force of Arm: rotate nut counter clockwise and test. Repeat as necessary.

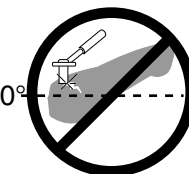
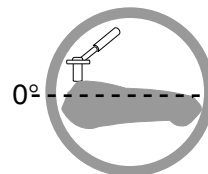

CAUTION: Arm must be held in the horizontal position during adjustment. Adjust at the top nut only. DO NOT turn the nut beyond the first sign of increased resistance. The bottom nut will turn during adjustment of the top nut; DO NOT apply any tool to the bottom nut. Serious damage to the Arm may occur if these instructions are not followed.



Tilt the monitor/keyboard bracket up or down to desired angle by turning the lever.

ii

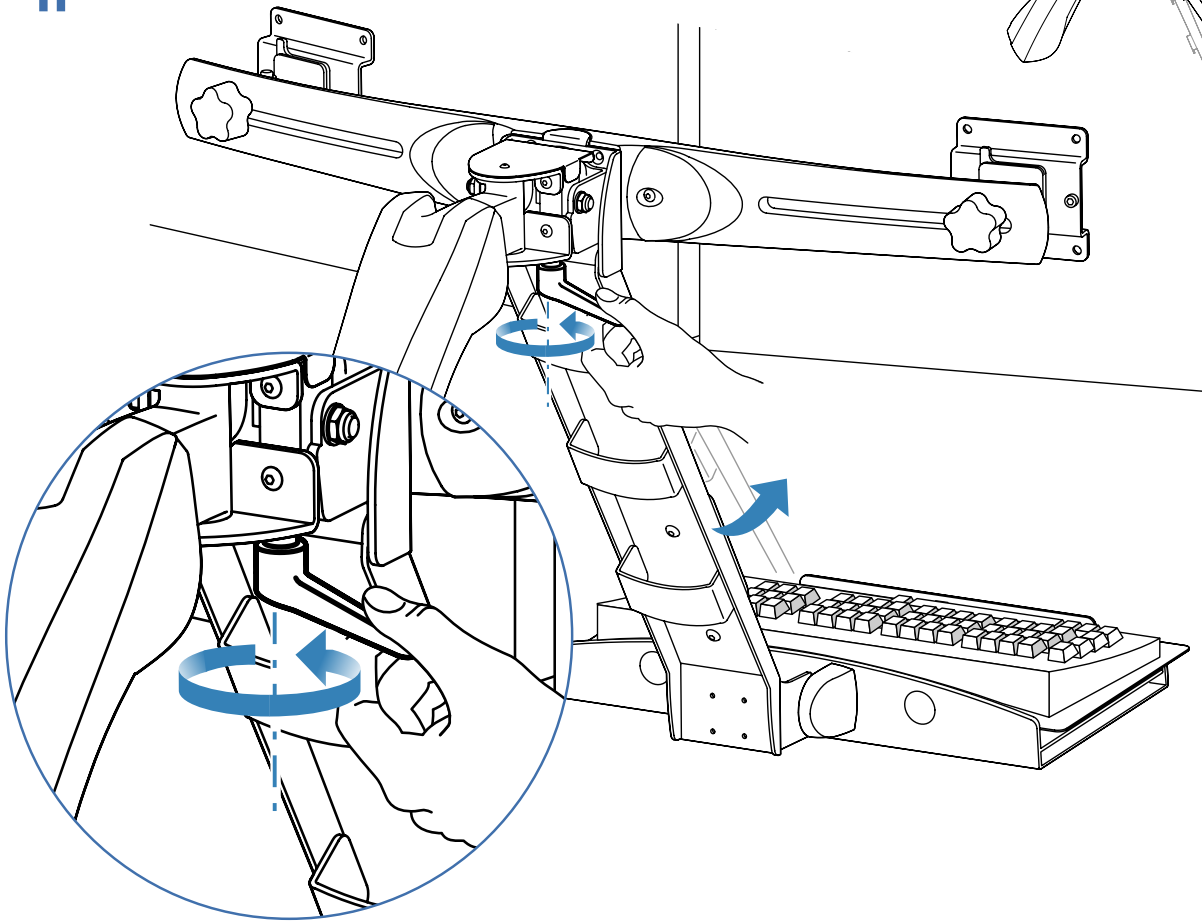

iii

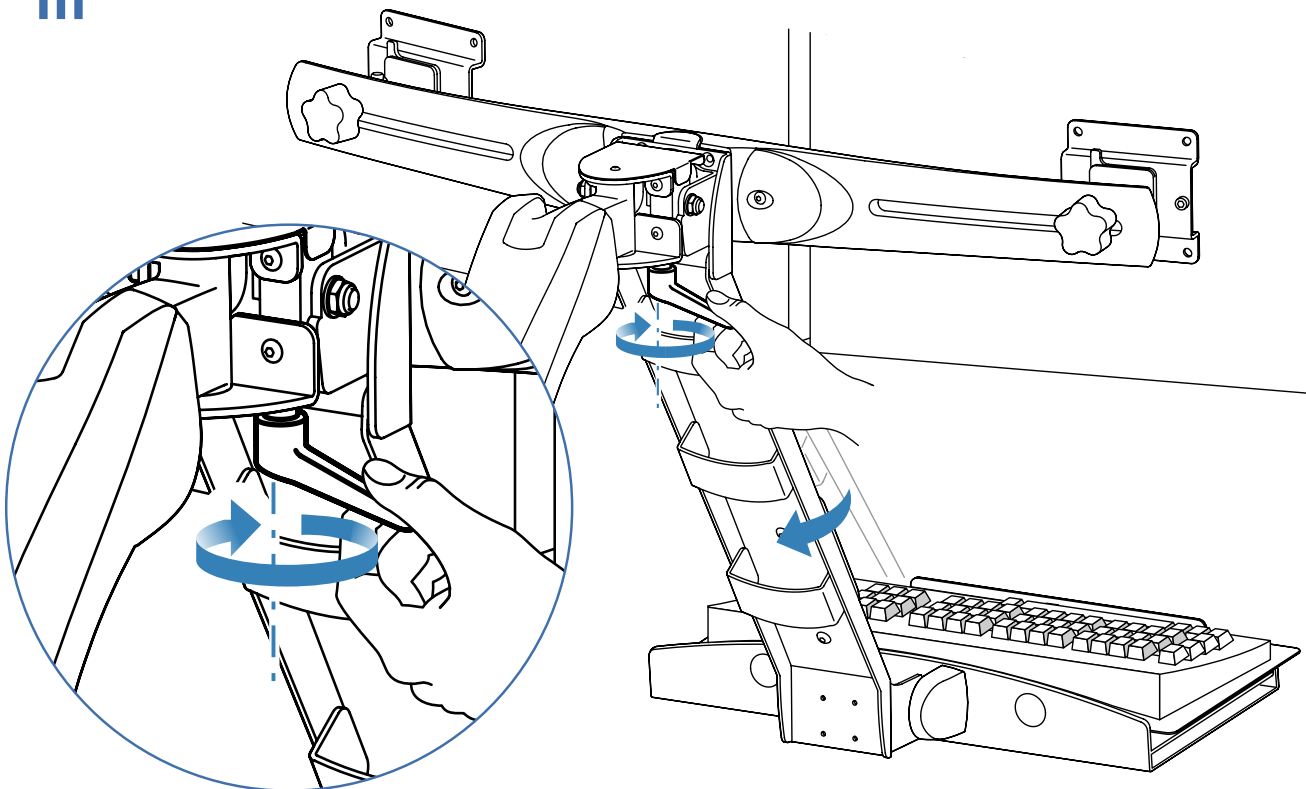



Pivot each monitor side-to-side through their entire range of motion and follow adjustment steps below if necessary.

ii

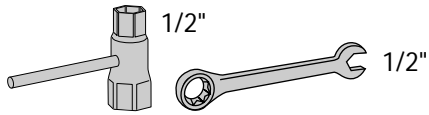

i

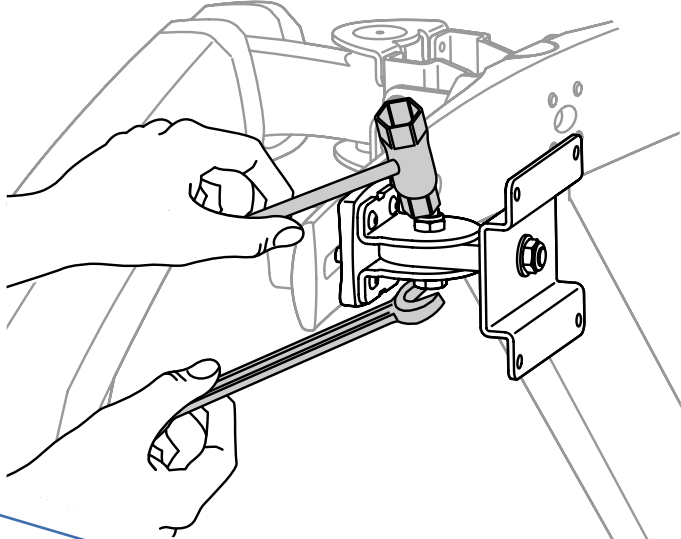
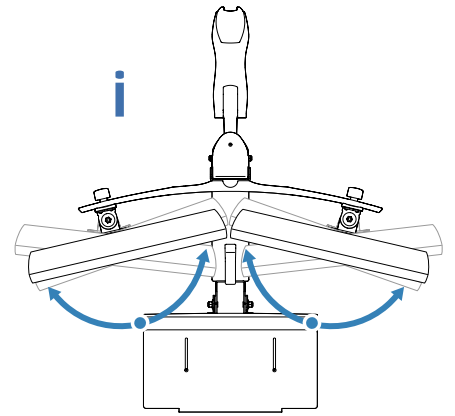

iii

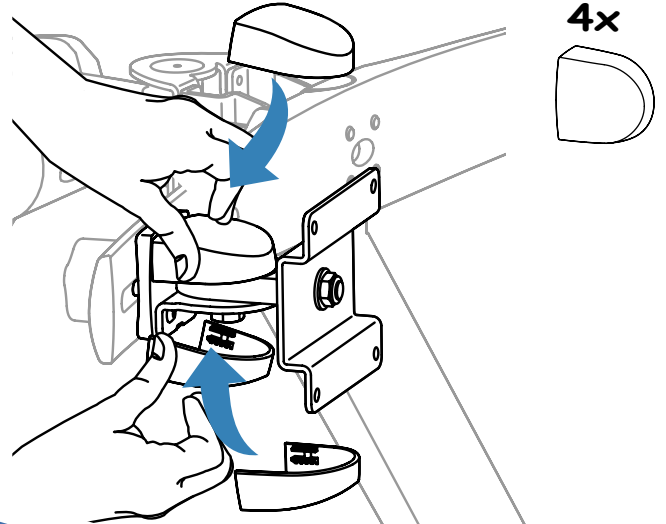

Rotate the monitor from portrait to landscape, through it's entire range of motion and follow adjustment steps below if necessary.

i

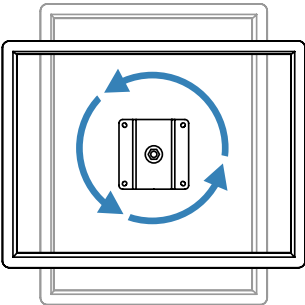

ii

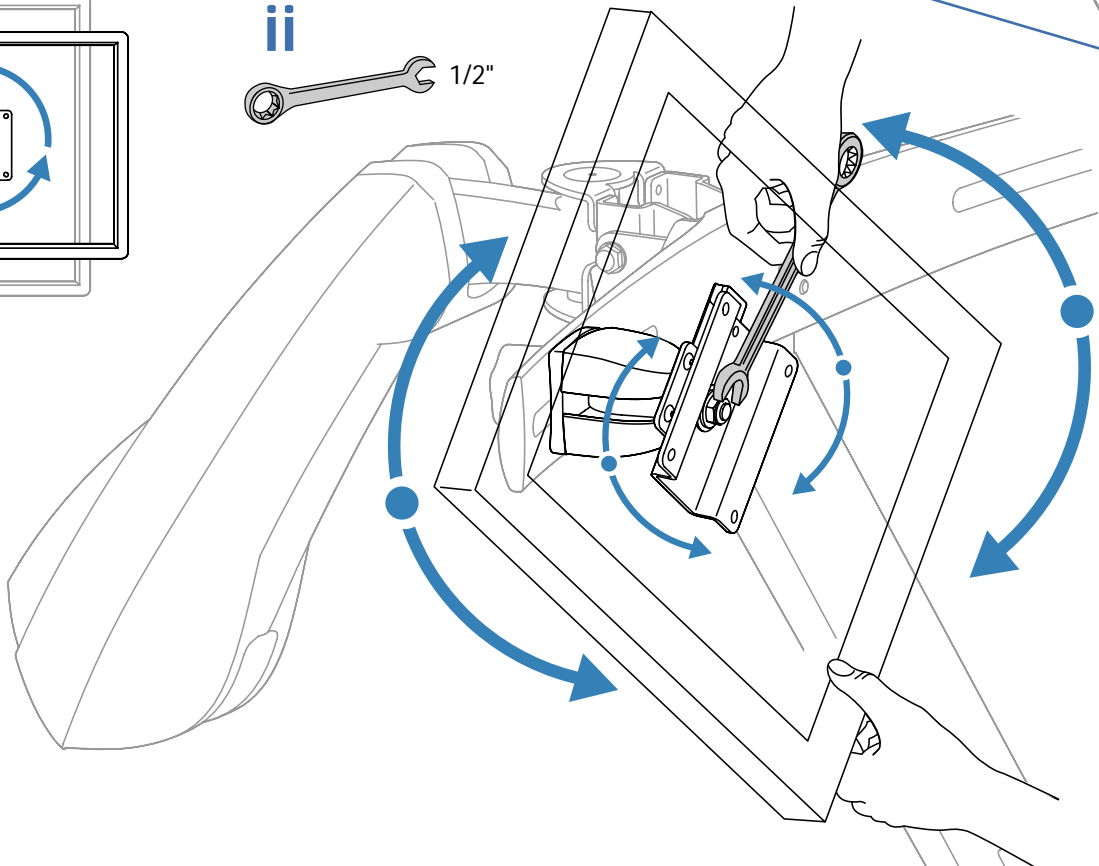
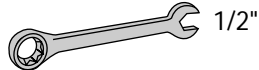



Tilt the keyboard tray up and down through its entire range of motion and follow adjustment steps below if necessary.

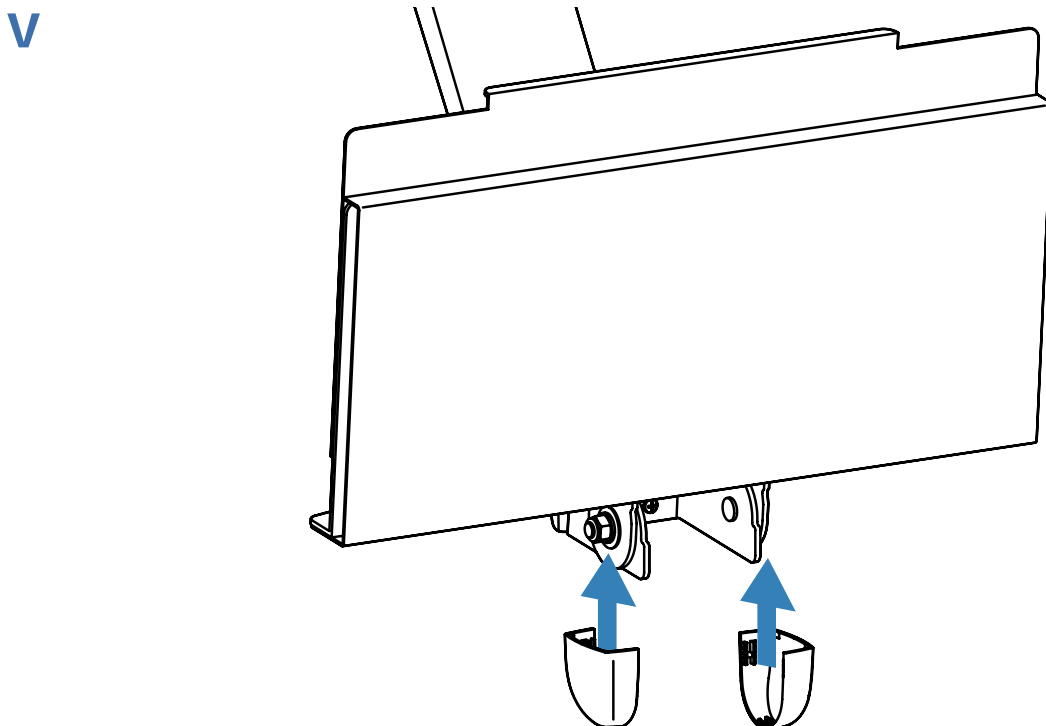
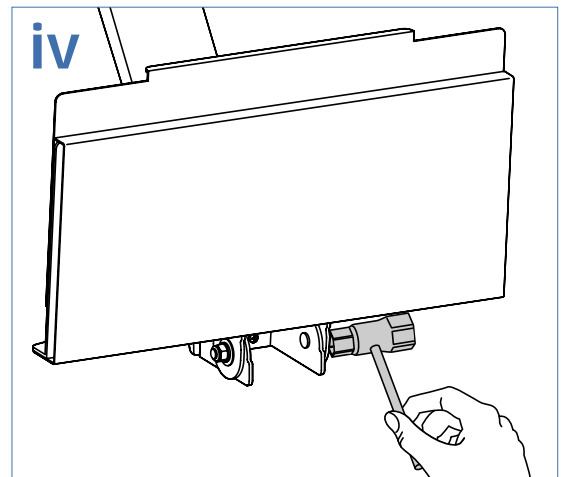
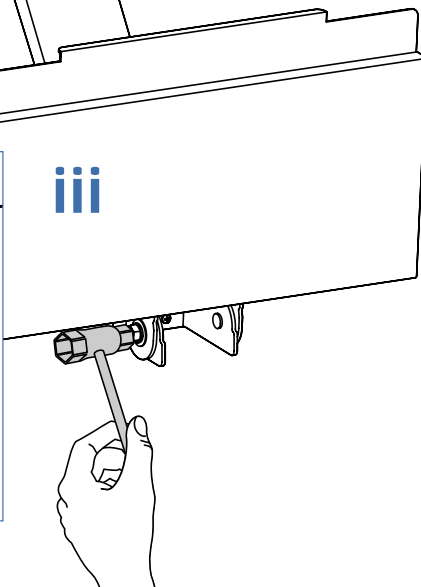
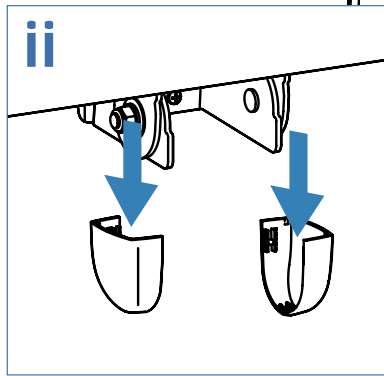
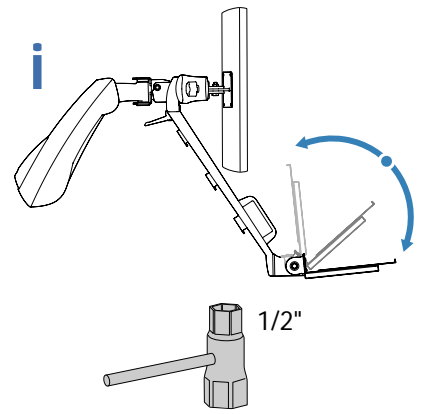
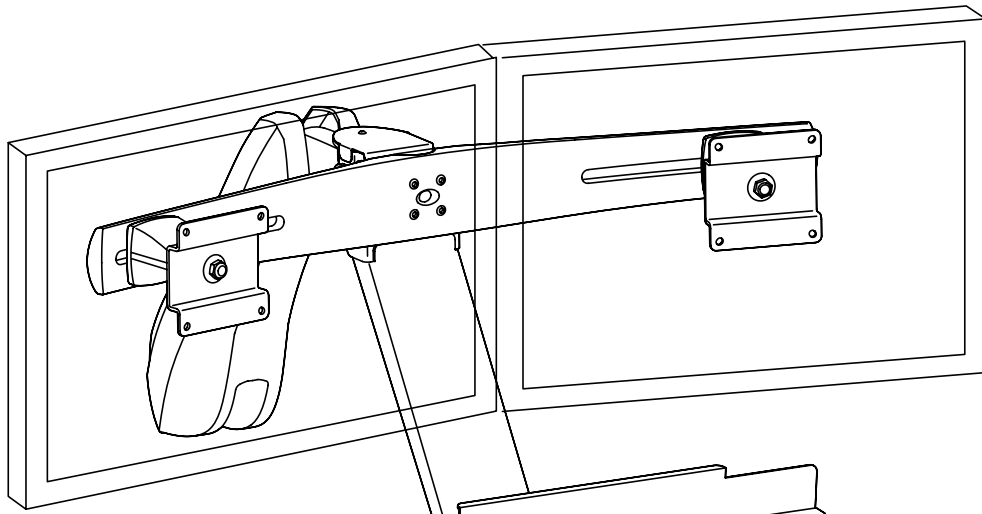



Tilt the crossbar clockwise or counterclockwise to level the monitors.

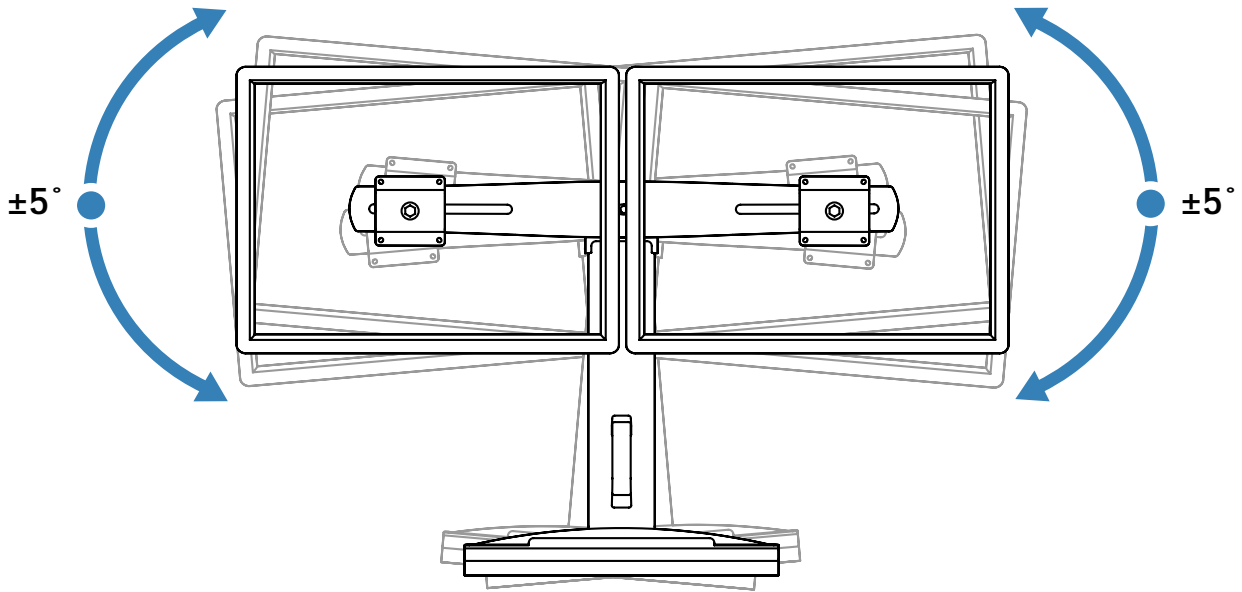

Mouse pouch option

a

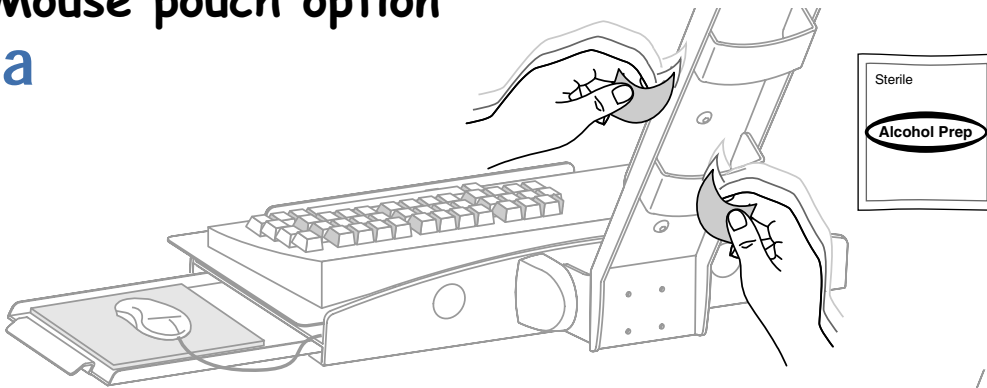

b

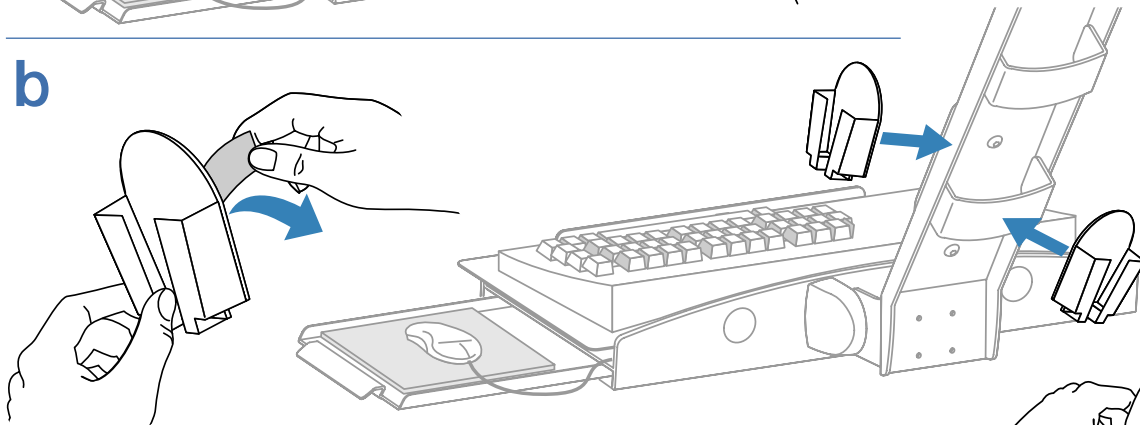

c

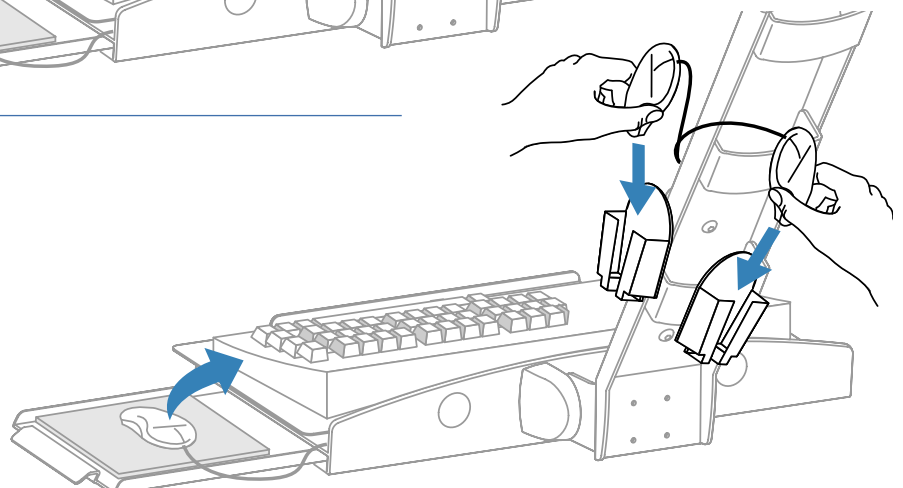

? Troubleshooting

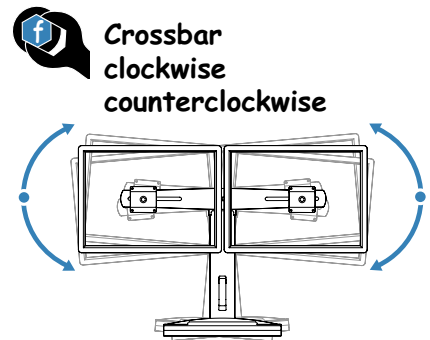
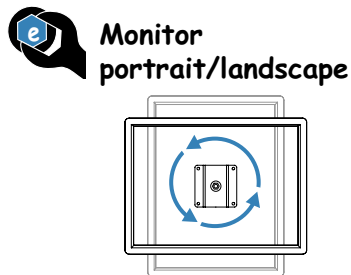
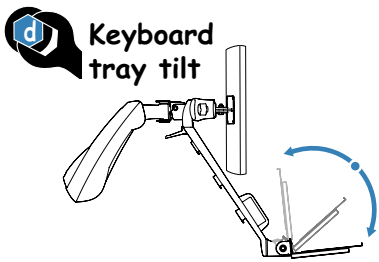
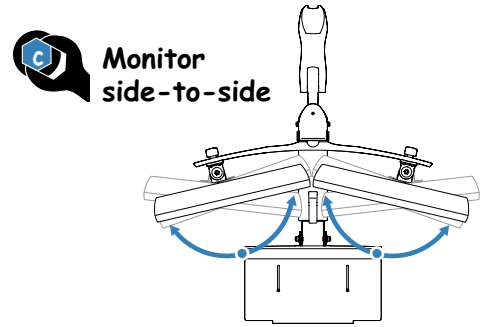
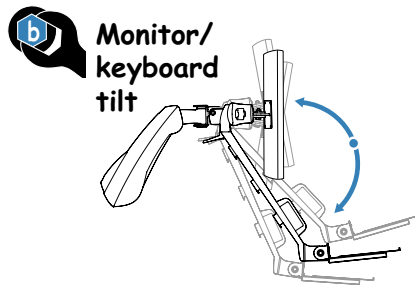
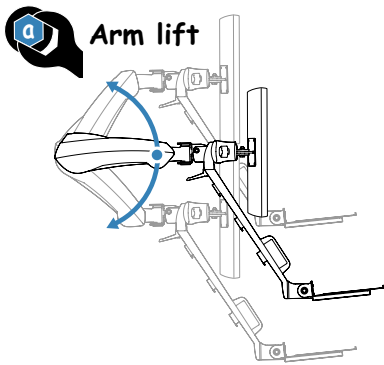

Symptom	Probable Cause	Solution
Arm lifts up and down too easily or with difficulty.	Arm lift tension needs adjustment	10
Monitor/keyboard tilts too easily or with difficulty.	Monitor/keyboard tilt needs adjustment.	11
Monitors pivot from side-to-side too easily or with difficulty	Monitor portrait/landscape needs adjustment.	12
Keyboard tray tilts up and down too easily or with difficulty	Keyboard tray tilt needs adjustment	12
Monitor rotates from portrait to landscape too easily or with difficulty.	Monitor portrait/landscape needs adjustment.	13
Monitors are not level	Crossbar needs to be adjusted clockwise or counterclockwise	14

For further assistance contact Ergotron.



USA 1-800-888-8458
Europe +31 (0)33-45 45 600

Ergotron Warranty

Ergotron warrants that its products will remain free of defects in material and workmanship for five (5) years. All subject to the exceptions, exclusions and limitations as set forth below.

Exceptions to this warranty include:

- Three (3) year warranty on all Neo-Flex™ by Ergotron products
- One (1) year warranty on all power supply components by Ergotron; battery carries a 90 day performance warranty and six (6) month warranty against manufacturer defects.
- OEM products resold by Ergotron are warranted by the respective manufacturer

Exclusive Remedy: If any Ergotron equipment is or becomes defective in material or workmanship during the warranty period, Ergotron, at its sole discretion, may replace or repair the unit at a designated Ergotron location or at the customer location. The purchaser must get pre-approved authorization to return product to Ergotron. The Purchaser must contact Ergotron to obtain an RMA (Return Material Authorization) number. Ergotron will promptly repair or replace the item and ship it to Purchaser at no charge to the Purchaser. Performance of repair or replacement does not renew or extend the warranty period.

THIS REMEDY IS THE EXCLUSIVE REMEDY FOR BREACH OF WARRANTY AS TO THE EQUIPMENT, except in respect to the personal injury. Purchaser shall give Ergotron immediate written notice of any personal injury resulting from use of Ergotron equipment.

Exclusions and Limitations: Ergotron disclaims liability for injuries or losses caused by or associated with installation or use of its equipment in any manner other than in strict conformance with the instructions set forth in its installation manuals, supplemental assembly and installation instruction sheets, technical bulletins or product literature or by equipment that has been altered, damaged or misused.

Warranty on fully charge batteries left in an unused state for more than three (3) consecutive months is automatically void.

Warranty on fully discharged batteries left in an unused state for more than three (3) consecutive days is automatically void.

Purchaser has not relied upon and Ergotron disclaims any and all warranties other than the expressed warranty stated above, subject to the exclusions and limitations provided herein. Ergotron disclaims all other warranties, expressed or implied, including but not limited to the warranties of merchantability and fitness for a particular purpose.

Ergotron further disclaims liability to purchaser and all others for all consequential, incidental and special damages caused by or in connection with the products, their use or misuse, and their performance or nonperformance.

821-842-00



© 2006 Ergotron, Inc.
All rights reserved.

While Ergotron, Inc. makes every effort to provide accurate and complete information on the installation and use of its products, it will not be held liable for any editorial errors or omissions (including those made in the process of translation from English to another language), or for incidental, special or consequential damages of any nature resulting from furnishing this instruction and performance of equipment in connection with this instruction. Ergotron, Inc. reserves the right to make changes in the product design and/or product documentation without notification to its users. For the most current product information, or to know if this document is available in languages other than those herein, please contact Ergotron Customer Care at: 800-888-8458 or consult the Ergotron, Inc. website at: www.ergotron.com. No part of this publication may be reproduced, stored in a retrieval system, or transmitted in any form or by any means, electronic, mechanical, photocopying, recording or otherwise without the prior written consent of Ergotron, Inc., 1181 Trapp Road, Eagan, Minnesota, 55121, USA Patents Pending and Patented U.S. & Foreign. Ergotron is a registered trademark of Ergotron, Inc.