

Ergotron® Tablet Management Carts and Desktop Module

Tablet Management Carts

Front View

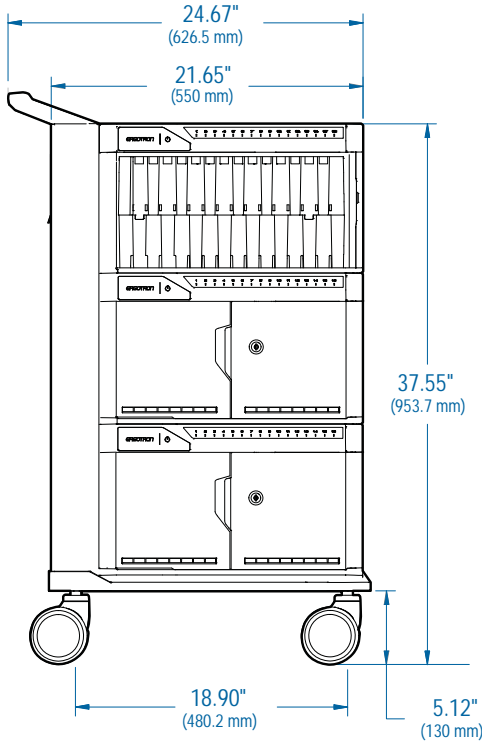

Right Side View

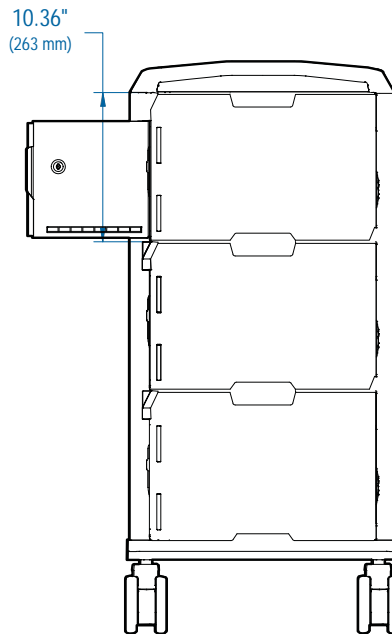

Left Side View

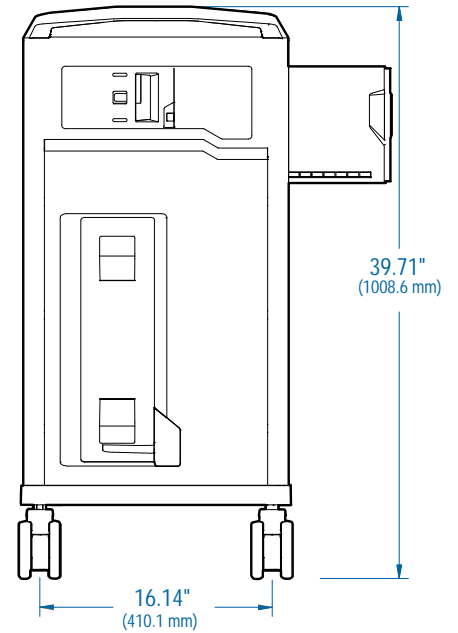

Top View

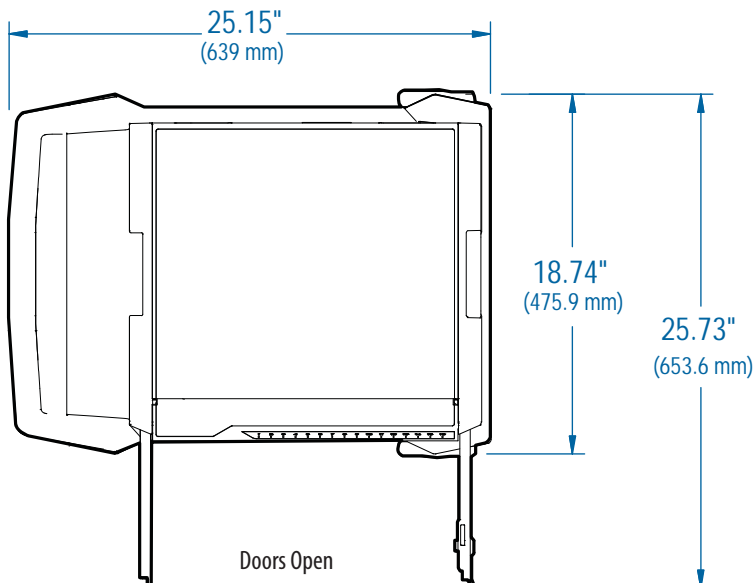

Tablet Cart with Two or Three Modules

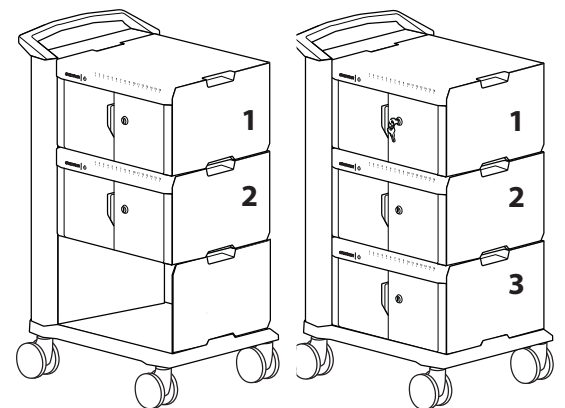

Ergotron® Tablet Management Carts and Desktop Module

Desktop Module

Front View

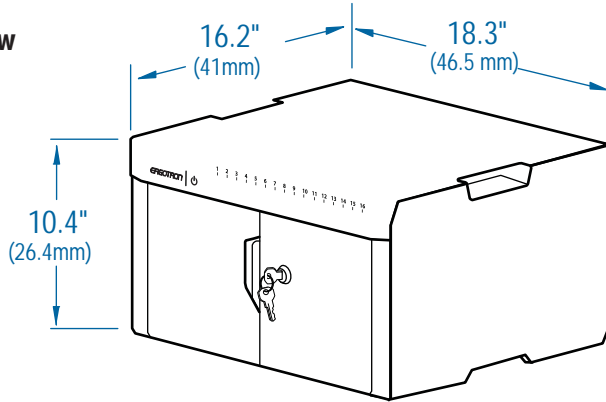

Rear View

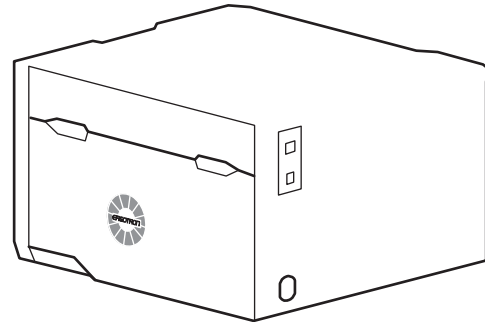

Maximum tablet size

- Individual tablet dimensions (including cover): up to 10.8 H x 7.7 W x 0.95 in D (27.4 x 19.6 x 1.3 cm)
- Individual tablet weight: up to 2.2 lb (1 kg)

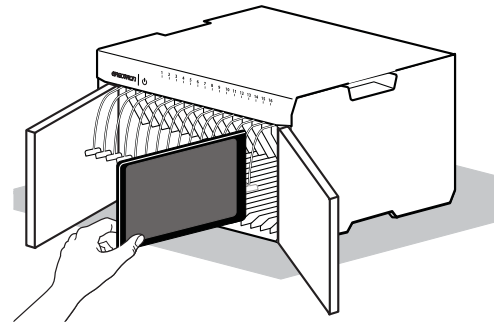
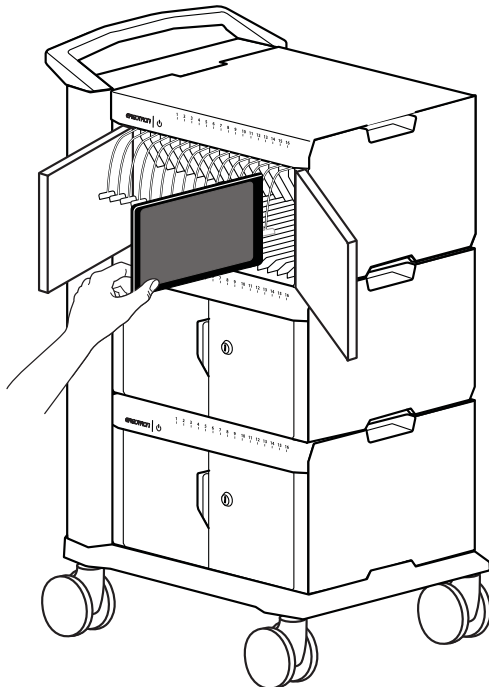

© 2012 Ergotron, Inc. rev. 03/05/2012 DIM-TCC Content is subject to change without notification

Americas Sales and Corporate Headquarters

St. Paul, MN USA
(800) 888-8458
+1-651-681-7600
www.ergotron.com
sales@ergotron.com

EMEA Sales

Amersfoort, The Netherlands
+31 33 45 45 600
www.ergotron.com
info.eu@ergotron.com

APAC Sales

Tokyo, Japan
www.ergotron.com
apaccustomerservice@ergotron.com

Worldwide OEM Sales

www.ergotron.com
info.oem@ergotron.com

