

 www.ergotron.com
 USA 1-800-888-8458
 Europe +31 (0)33-45 45 600
 China 86-769-86018920

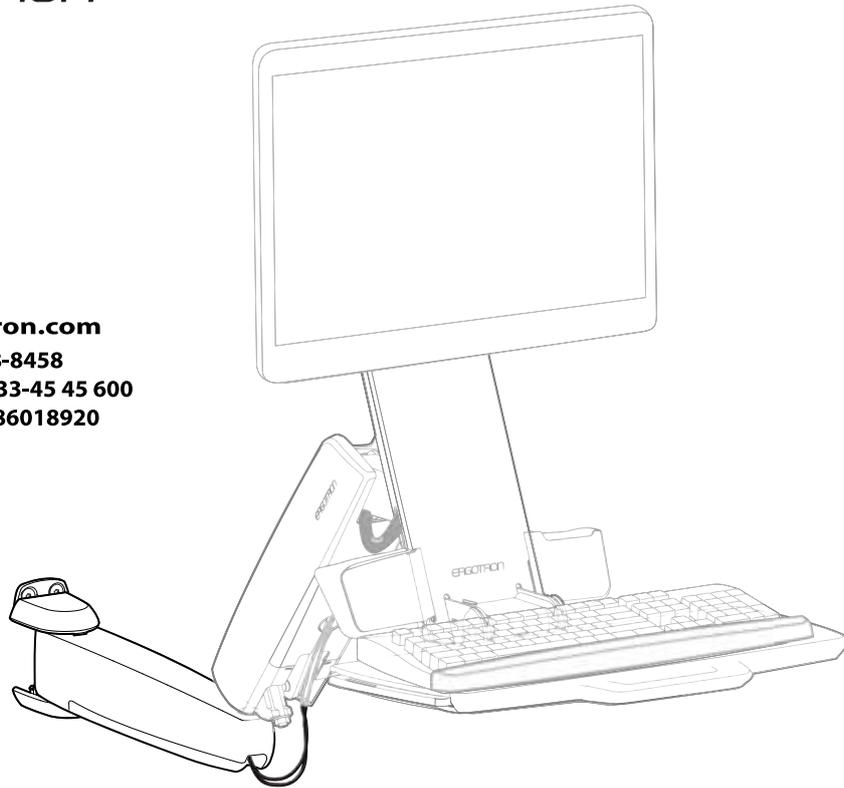

	A	B	C	D
1	1x 	1x 	1x 	1x 
2	1x  2x 	1x 		
3	1x  M6 x 10mm 4x  M10 x 18mm	1x 		
4	 3 mm  6 mm	1x 		
5	2x  1x  4x 	1x 		

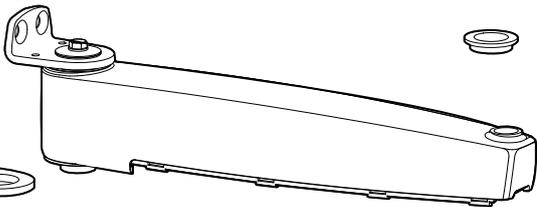
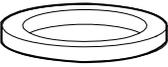
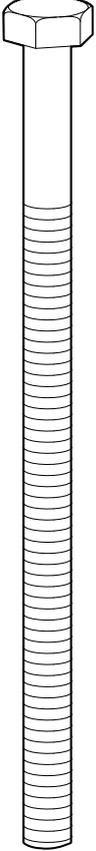
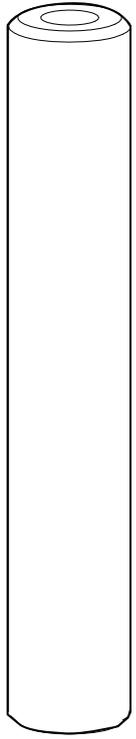
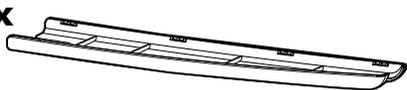
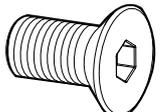
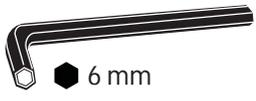
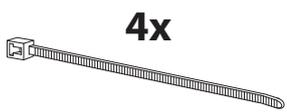
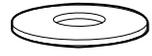
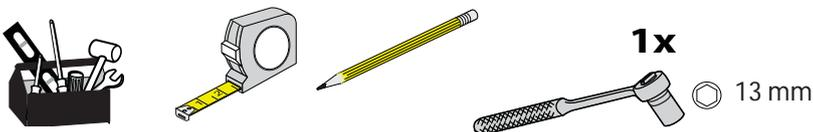

Dimensions

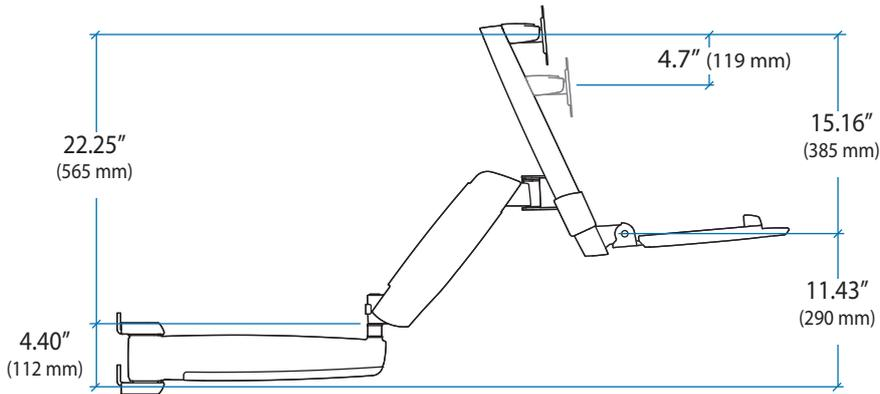

Side View

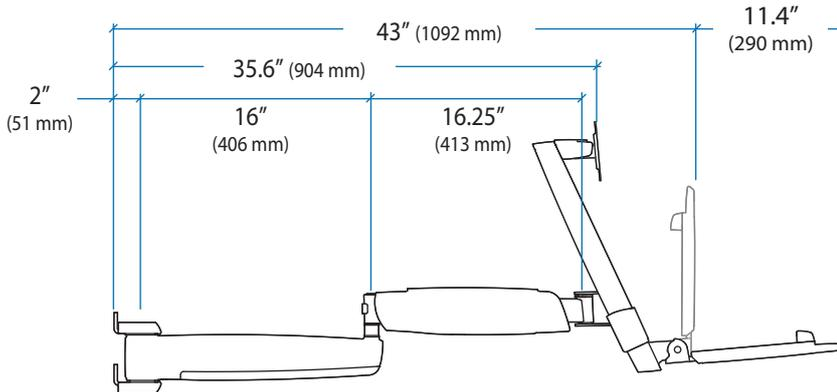

Side View

Range of Motion

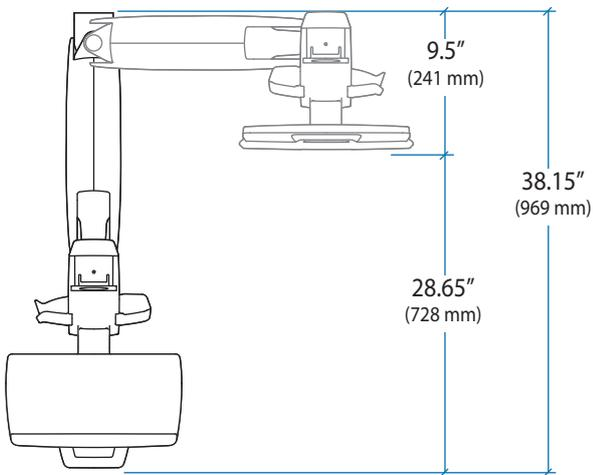
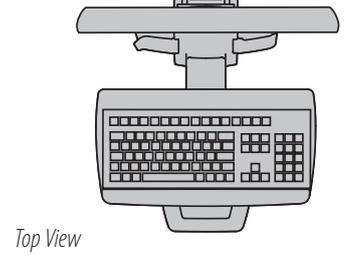
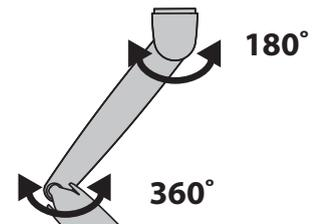

Top View

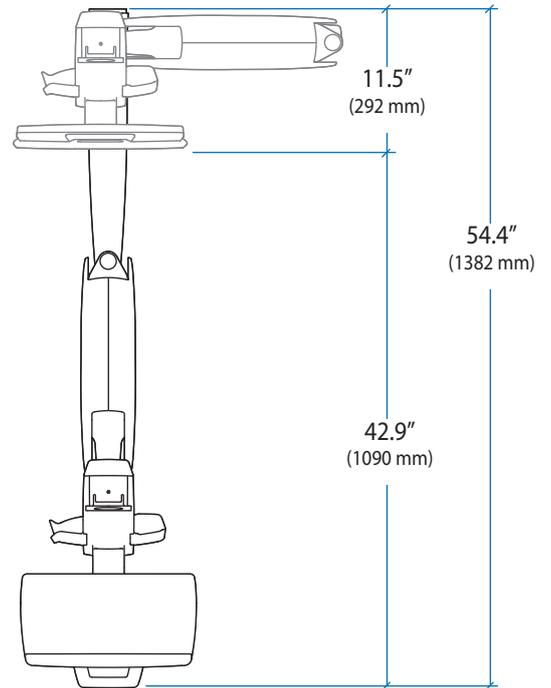

Top View

Wall Mount Bracket

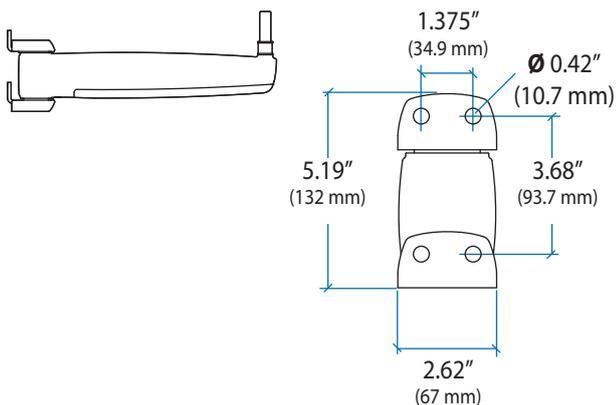

Set Your Workstation to Work For YOU!

Configure su estación de trabajo para que trabaje para USTED.

Ajustez votre station de travail en fonction de VOS besoins !

Richten Sie Ihren Arbeitsplatz so ein, dass er für SIE arbeitet!

Stel uw workstation zo in dat het voor U werkt!

Approntare la stazione di lavoro nella posizione ergonomica ottimale.

一人ひとりにピッタリのワークステーション!

按照您自身的需要设置工作站!

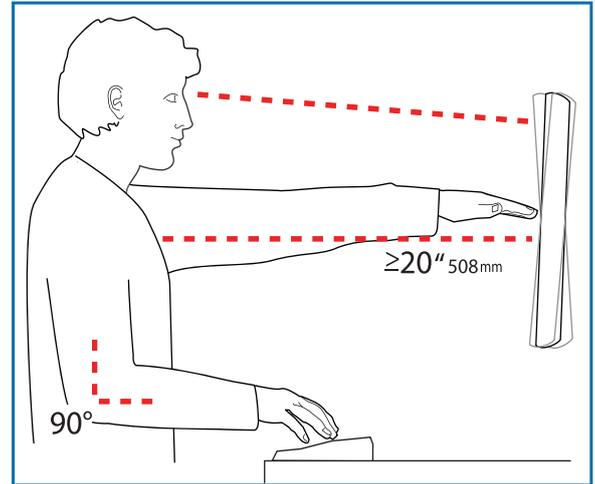

Height Position top of screen slightly below eye level.
Position keyboard at about elbow height with wrists flat.
Distance Position screen an arm's length from face—at least 20" (508mm).
Position keyboard close enough to create a 90° angle in elbow.
Angle Tilt screen to eliminate glare.
Tilt the keyboard back 10° so that your wrists remain flat.

To Reduce Fatigue

Breathe - Breathe deeply through your nose.
Blink - Blink often to avoid dry eyes.
Break - 2 to 3 minutes every 20 minutes
• 15 to 20 minutes every 2 hours.

Altura Coloque el borde superior de la pantalla ligeramente por debajo de la altura de sus ojos.
Coloque el teclado aproximadamente a la altura de los codos con las muñecas planas.
Distancia Coloque la pantalla a una distancia de un brazo desde la cara, esto es, unos 50 cm (20 pulgadas).
Coloque el teclado lo suficientemente cerca para que el codo forme un ángulo de 90°.
Ángulo Incline la pantalla para eliminar los reflejos.
Incline el teclado 10° hacia atrás para que las muñecas sigan en posición plana.

Para reducir la fatiga

Respirar - Respire hondo por la nariz.
Parpadear - Parpadee a menudo para que no se sequen los ojos.
Descansar • 2 o 3 minutos cada 20 minutos
• 15 o 20 minutos cada 2 horas.

Hauteur Positionnez l'écran du haut légèrement en dessous du niveau du regard.
Positionnez le clavier à peu près à la même hauteur que vos coudes, pour que vos poignets soient à plat.
Distance Positionnez l'écran à un bras de distance de votre visage, à au moins 508 mm (20 pouces).
Positionnez le clavier assez près pour que vos coudes forment un angle de 90°.
Angle Inclinez l'écran pour ne pas être ébloui.
Inclinez le clavier vers l'arrière de 10° pour que vos poignets soient à plat.

Pour réduire la fatigue

Respirez - Respirez profondément par votre nez.
Clignez des yeux - Clignez souvent des yeux pour ne pas avoir les yeux secs.
Faites des pauses • 2 à 3 minutes toutes les 20 minutes
• 15 à 20 minutes toutes les 2 heures.

Höhe Positionieren Sie die obere Kante des Bildschirms knapp unter Augenhöhe.
Positionieren Sie die Tastatur bei flach aufgelegten Handgelenken auf Ellenbogenhöhe.
Abstand Positionieren Sie den Bildschirm mindestens eine Armlänge (50 cm) von Ihrem Gesicht entfernt.
Positionieren Sie die Tastatur nahe genug, um einen Ellenbogenwinkel von 90° zu ermöglichen.
Winkel Neigen Sie den Bildschirm so, dass ein Spiegeleffekt vermieden wird.
Neigen Sie die Tastatur um 10° nach hinten, sodass Ihre Handgelenke flach aufliegen.

Vermeiden von Ermüdungserscheinungen

Atmen - Atmen Sie tief durch die Nase ein und aus.
Blinzeln - Blinzeln Sie so oft wie möglich, um trockene Augen zu vermeiden.
Pausen • Machen Sie alle 20 Minuten eine Pause von 2-3 Minuten
• Machen Sie alle 2 Stunden eine Pause von 15-20 Minuten.

Hoogte Zet de bovenkant van het scherm iets boven ooghoogte.
Plaats het toetsenbord op ongeveer ellebooghoogte met de polsen plat.
Afstand Plaats het scherm op een armlengte van uw gezicht — op ten minste 508 mm (20 in).
Zet uw toetsenbord zo dichtbij dat u een hoek van 90° in de ellebogen hebt.
Hoek Kantel het scherm om weerspiegeling te elimineren.
Kantel het toetsenbord 10° naar achteren, zodat uw polsen plat blijven liggen.

Om vermoeidheid te verminderen

Ademen - Adem diep door uw neus in en uit.
Knipperen - Knipper regelmatig om droge ogen te vermijden.
Pauses nemen • 2 tot 3 minuten elke 20 minuten
• 15 tot 20 minuten elke 2 uur.

Altezza Posizionare la parte superiore dello schermo leggermente sotto il livello degli occhi.
Posizionare la tastiera circa all'altezza dei gomiti, in modo che i polsi siano piatti.
Distanza Posizionare lo schermo a un braccio di distanza dal viso, almeno a 20" (508 mm) di distanza.
Posizionare la tastiera affinché sia abbastanza vicina da costringere i gomiti a un angolo di 90°.
Angolazione Inclinare lo schermo in modo da eliminare i riflessi.
Inclinare la tastiera indietro di 10° in modo che i polsi rimangano piatti.

Per ridurre l'affaticamento

Respirazione - Respirare profondamente dal naso.
Battito delle palpebre - Battere spesso le palpebre per evitare che gli occhi si asciughino.
Pause • Fare una pausa di 2 - 3 minuti ogni 20 minuti
• Fare una pausa di 15 - 20 minuti ogni 2 ore.

高さ スクリーンの上端が目よりわずかに下に来るようにします。
キーボードが、手首を水平に伸ばした状態でひじとほぼ同じ高さに来るようにします。
距離 スクリーンを顔から腕の長さ分(少なくとも508mm)離します。
ひじが直角になる位置にキーボードを置きます。
角度 反射光をなくすようにスクリーンの角度を調整します。
キーボードを後方に10°傾けて、手首が水平になるようにします。

疲れを軽減する方法

呼吸 - 鼻から深く呼吸します。
まばたき - 目の乾燥を防ぐために頻りにまばたきしてください。
休憩 • 20分ごとに2~3分
• 2時間ごとに15~20分

高度 屏幕顶端的位置要稍低于视线高度。
将键盘放置在大约肘部的高度并且手腕要能放平。
距离 将屏幕摆放在距离面部一臂长的位置——至少 508mm (20")。
键盘的位置要够近, 以使肘部形成直角。
角度 倾斜屏幕以消除眩光。
将键盘向后倾斜 10 度, 使手腕能保持放平。

为了减轻疲劳

呼吸 - 通过鼻子深呼吸。
眨眼 - 经常眨眼可避免眼睛干涩。
休息 • 每隔 20 分钟休息 2 至 3 分钟
• 每隔 2 小时休息 15 至 20 分钟。

Learn more about ergonomic computer use at:

Más información sobre el uso ergonómico de ordenadores:

Apprenez-en plus sur l'utilisation ergonomique d'un ordinateur sur :

Weitere Informationen zur ergonomischen Computernutzung finden Sie unter:

Leer meer over ergonomisch computergebruik op:

Per ulteriori informazioni sull'uso ergonomico del computer:

人間工学的なコンピュータの使用法については次のサイトを参照してください

想进一步了解以符合人体工程学的方式使用计算机的知识, 请访问:

www.computingcomfort.org

1 Calculate Mounting Height

Set Your Workstation to Work For YOU!

- Height** Position top of screen slightly below eye level.
Position keyboard at about elbow height with wrists flat.
- Distance** Position screen an arm's length from face—at least 20" (508mm).
Position keyboard close enough to create a 90° angle in elbow.
- Angle** Tilt screen to eliminate glare.

To Reduce Fatigue

- Breathe** Breathe deeply through your nose.
- Blink** Blink often to avoid dry eyes.
- Break** • 2 to 3 minutes every 20 minutes
• 15 to 20 minutes every 2 hours.

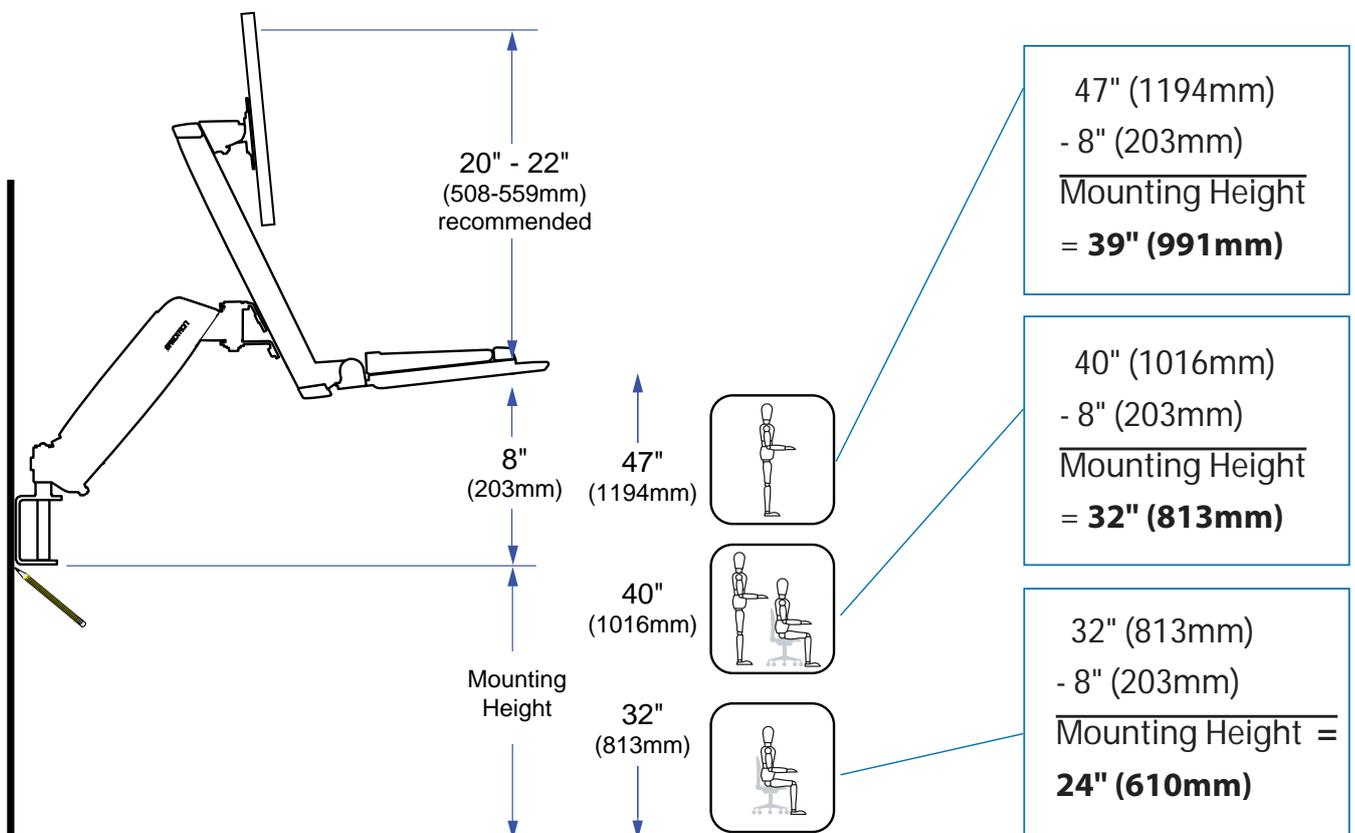



HD Extender Arm

NOTE: Mounting Height does not change if mounted to an HD Extender Arm.

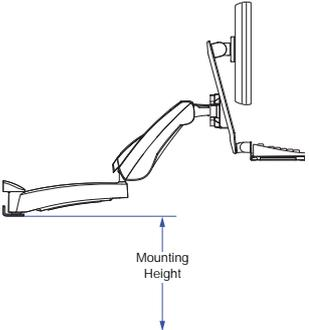

Mounting Height

Choose Mounting Solution (sold separately)



NOTE: Fasteners may unwind due to vibration caused by movement of mounting solution over time. Inspect mounting solution for loose fasteners on a routine basis. If desired, apply a light duty thread locking adhesive to fasteners before installation to prevent back-out.

2

2

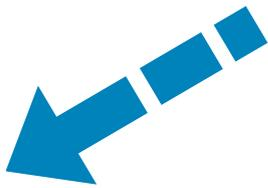
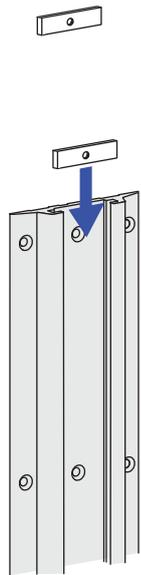
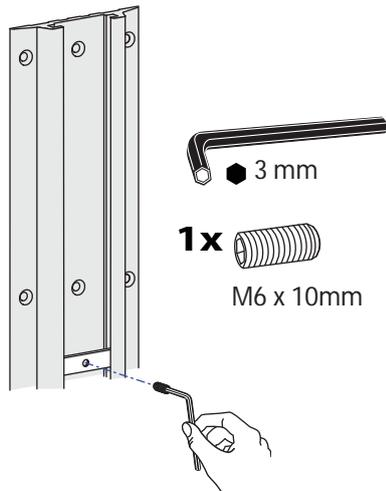
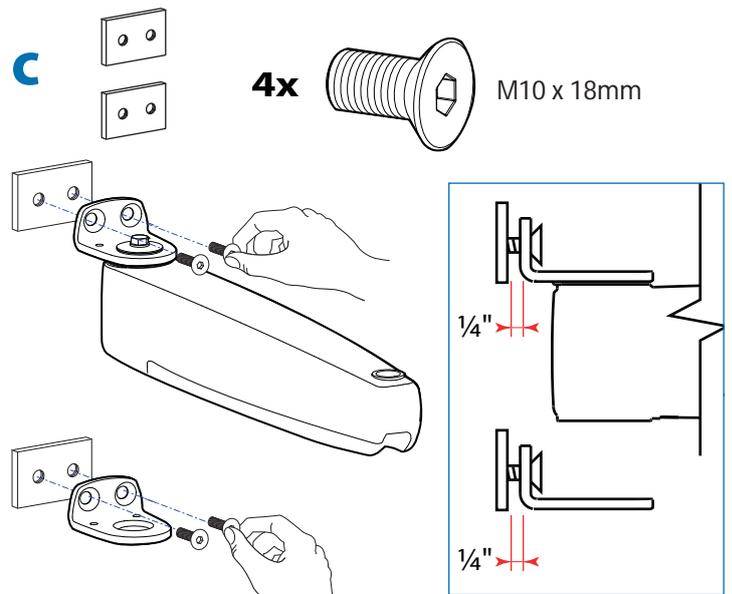
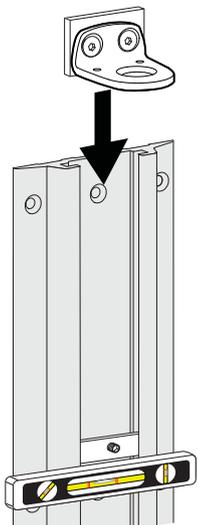
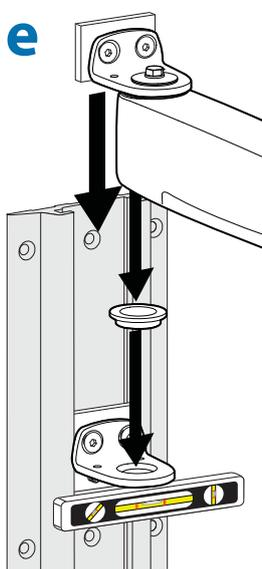
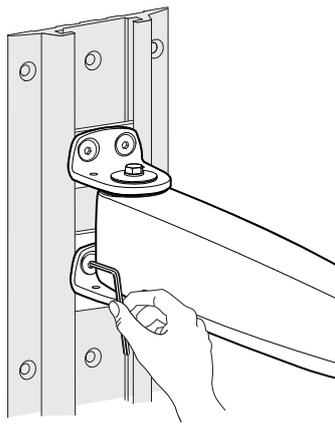
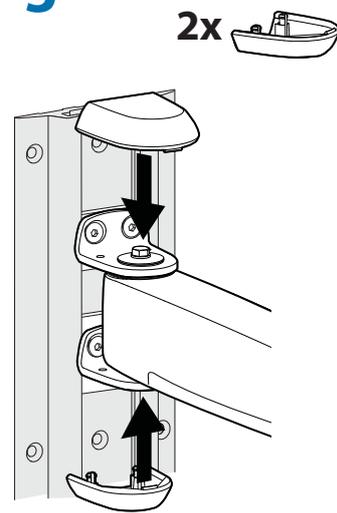
**a****b****c****d****e****f****g**

2

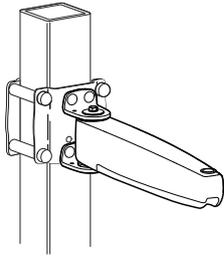

a

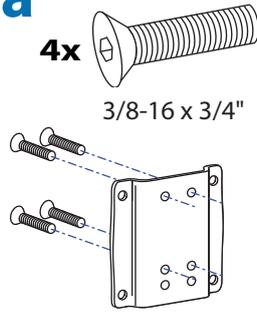

b

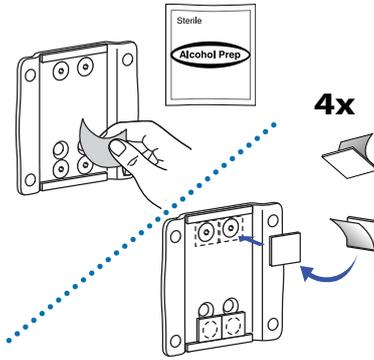

c

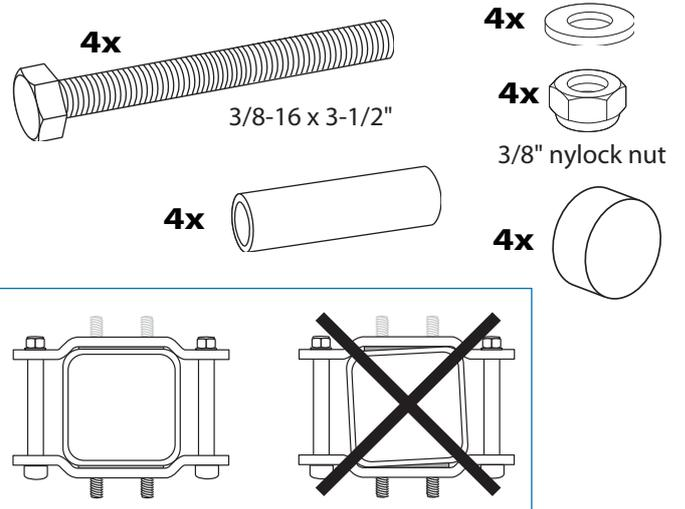
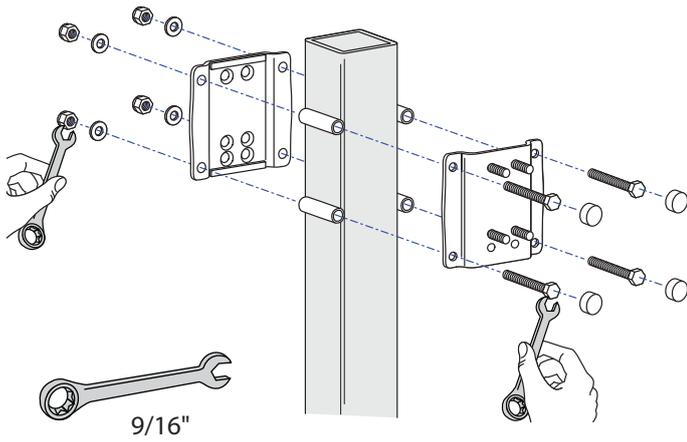

d

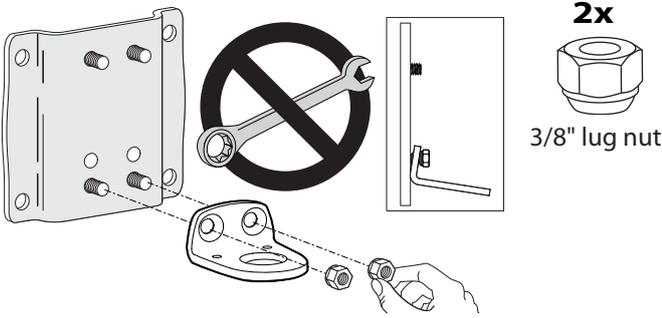

e

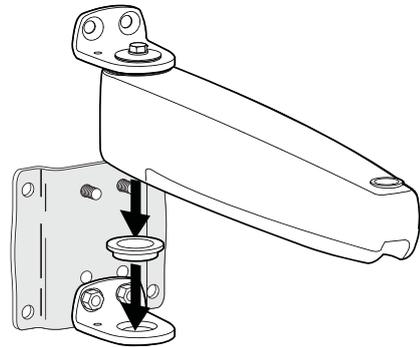

f

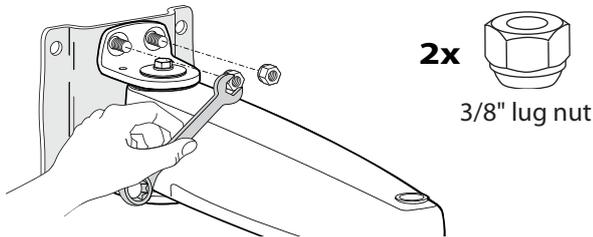

g

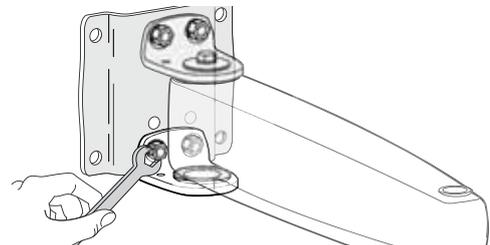

h

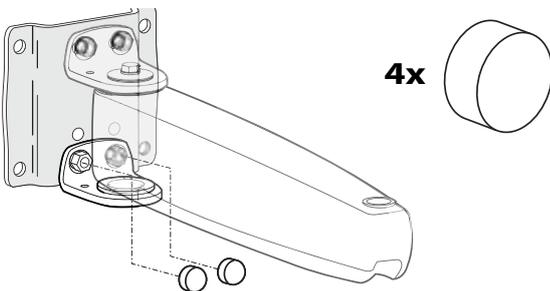

i

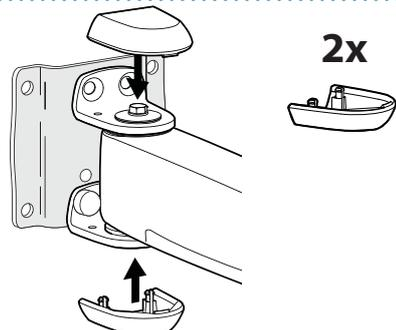

3

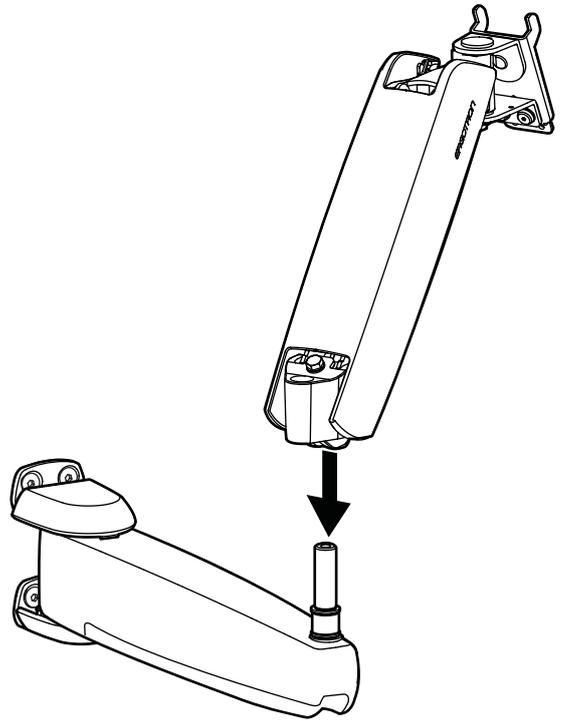
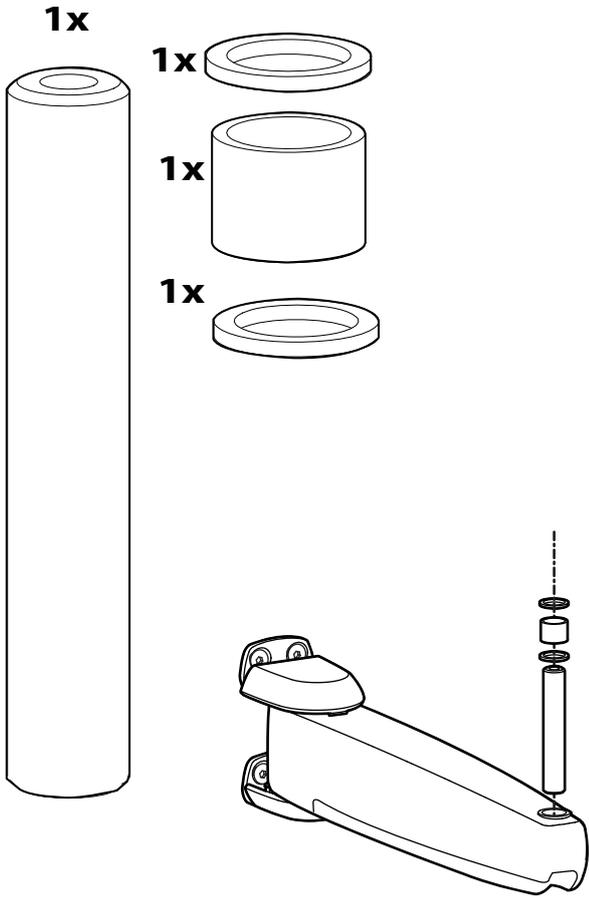

4

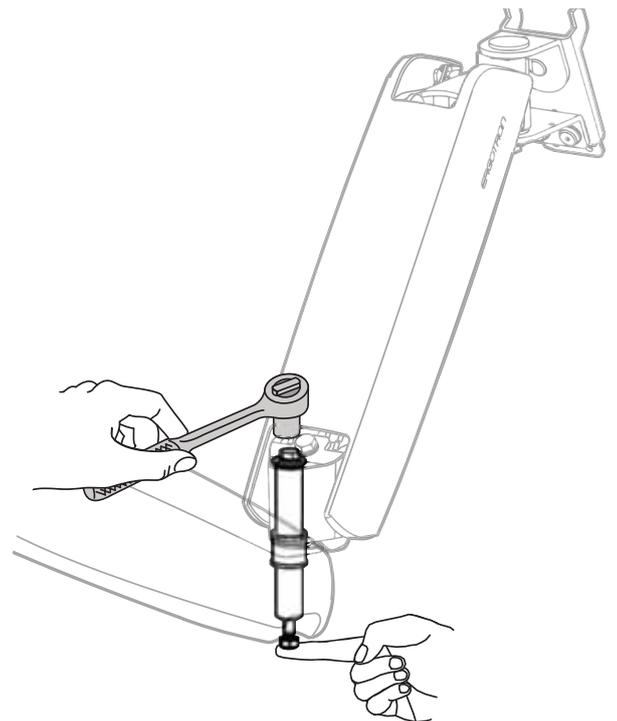
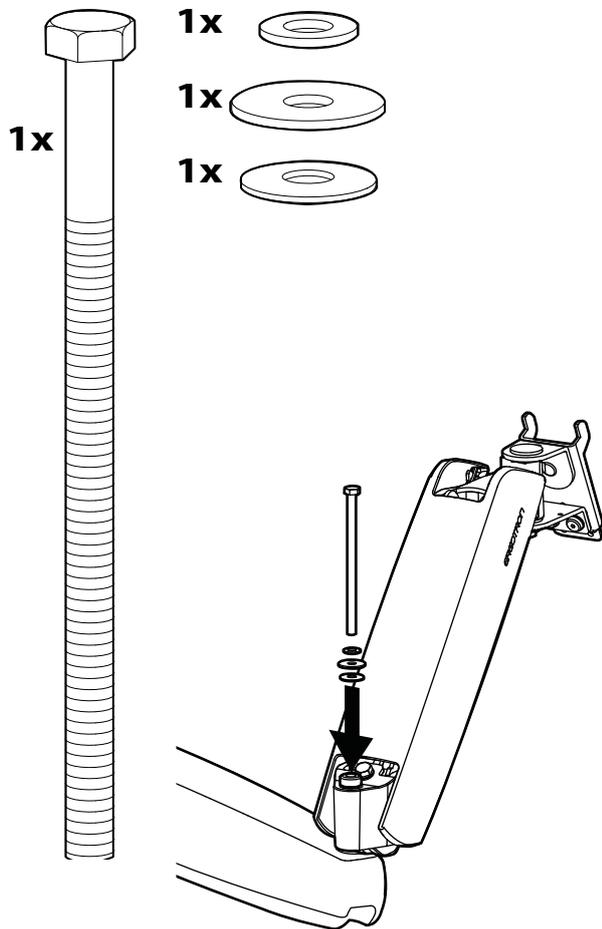

5

