

MA-1-J-C Monitor Arm

COMPLETED ASSEMBLY

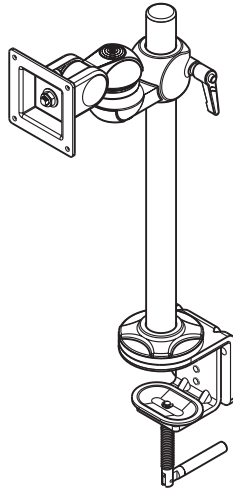

Loading up to 26 lbs / 11.8 kg

STEP 1 Join the Arm Components Together

Use the hardware supplied to attach together the following components:
 LA-511 Vesa
 LA-514 Connector

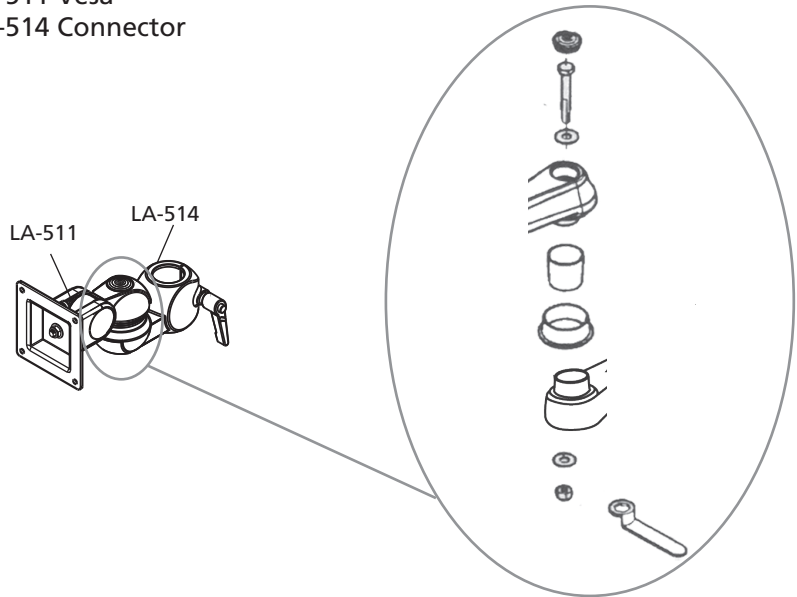

Assembly Guide

STEP 2 Mount the Clamp to the Worksurface

Use the hardware supplied to attach the LA-201 clamp to the worksurface. Then attach the LA-501A pole to the LA-201 clamp.

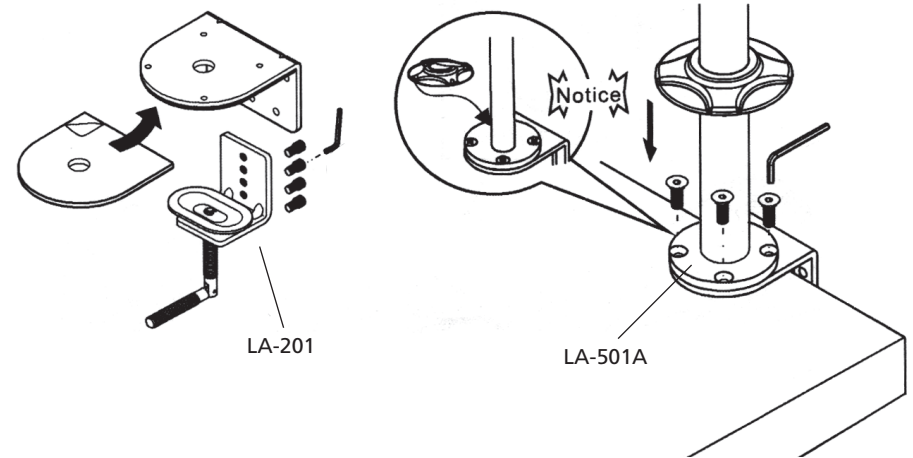

STEP 3 Mount the Monitor Arm to the Monitor

Place monitor face down on a flat surface. Place LA-511 Vesa on the back of the monitor and secure with screws supplied.

75mmx75mm VESA interface.

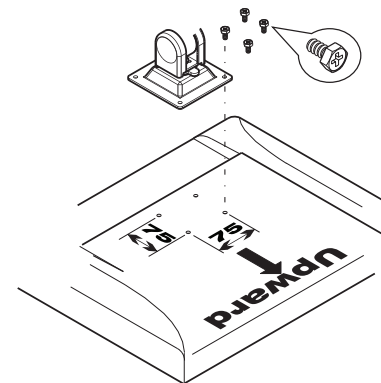

100mmx100mm VESA interface.

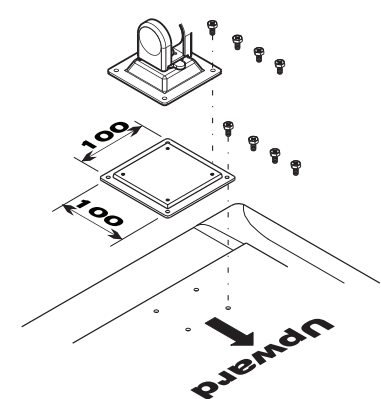

Assembly Guide

STEP 4 → Mount the Monitor Arm to the Pole

Insert the arm (with monitor on already) onto the pole and position at the desired viewing height. Use the lever to tighten, or secure it with supplied screw. Insert pole cap onto pole.

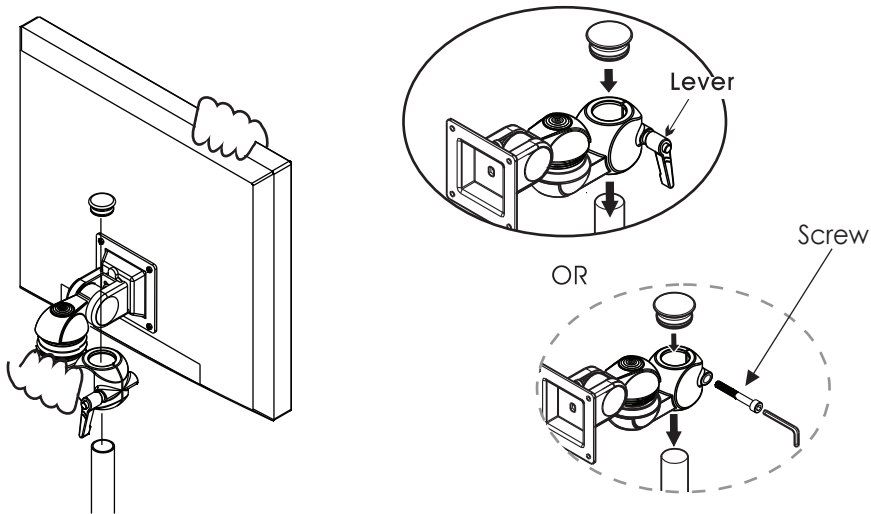

STEP 5 → Adjusting Swivel Tension

Use the wrench to tighten or loosen the arm.

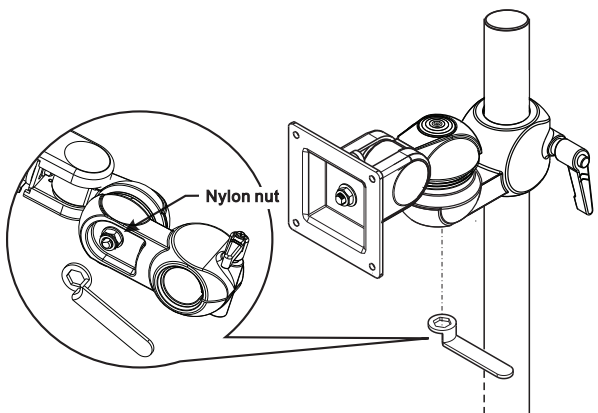

Assembly Guide

STEP 6 → Adjusting Vesa Tension

When assembling the arm with monitors of differing weights, you may find that the tension of the vesa needs to be adjusted to maintain the desired monitor position. If so, adjust as follows:

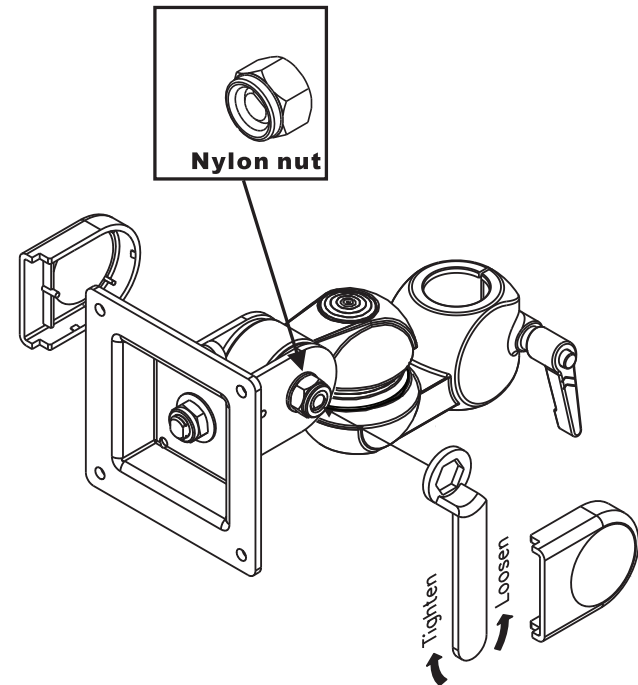

- Remove the two plastic vesa joint covers
- Find the nylon nut (not the screw head) and use the included wrench to adjust the tension.
- Use one hand to support the monitor and adjust the tension of the vesa.
 - Clockwise: more tension
 - Counterclockwise: less tension
- When the desired tension is achieved, replace the two plastic covers.

Caution:

- Support the monitor during the adjustment procedure.
- Only adjust the nylon nut (not the screw head).
- Do not disassemble the vesa.