

Installation and Assembly - Universal Adapter Bracket for 22" - 46" LCD Screens

Models: PLP-UNM, PLP-UNM-S, PLP-UNMP, PLP-UNMP-S

IMPORTANT! Read instruction sheet before you start installation and assembly.

Before you begin, make sure all parts shown are included with your product.

Parts List

Description	Qty	PLP-UNM Part #	PLP-UNM-S Part #	PLP-UNMP Part #	PLP-UNMP-S Part #
AA adapter plate	1	201-1016	201-4016	201-1016	201-4016
BB adapter bracket	2	201-1512	201-4512	201-1515	201-4515
CC allen wrench	1	560-9646	560-9646	560-0072	560-0072
DD M5 x 10mm screw	4	520-1063	520-1063	520-9250	520-9250

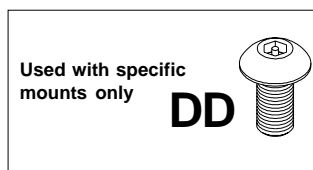
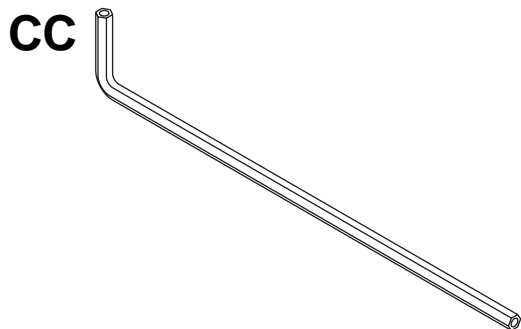
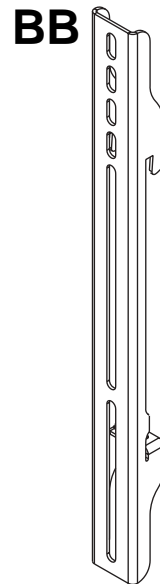
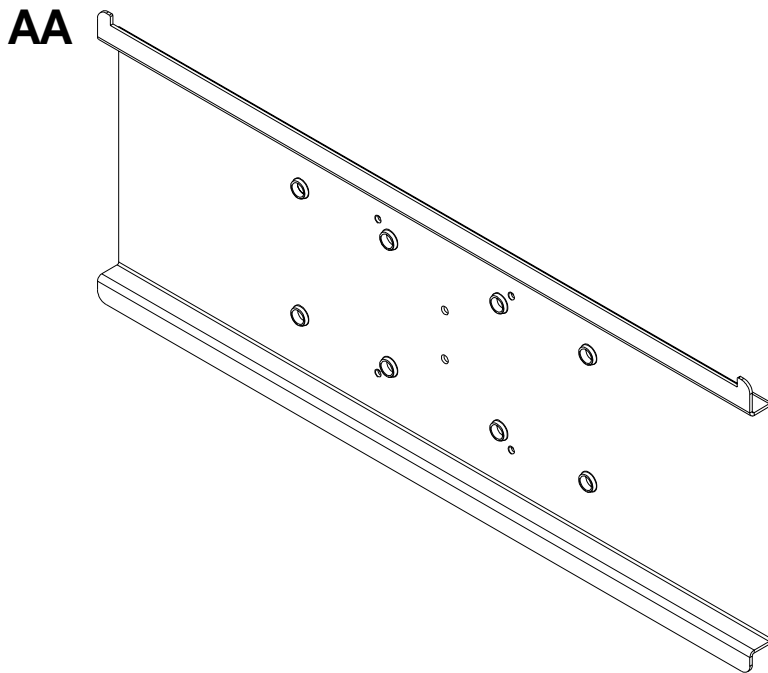

Security Adapter Bracket Fasteners



M4 x 12 mm (4)
510-1079



M5 x 12 mm (4)
520-1064

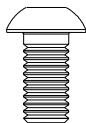

M6 x 12 mm (4)
520-1050



M6 x 20 mm (4)
520-9554

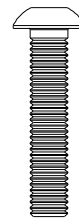

M5 x 25 mm (4)
520-1122

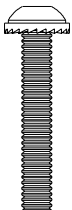

M4 x 25 mm (4)
510-1082

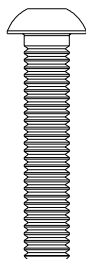

M6 x 30 mm (4)
520-1067

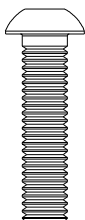

M6 x 25 mm (4)
520-1211

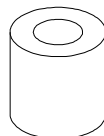

I.D. .26" (6.6 mm) (4)
540-1058



I.D. .203" (5.16 mm) (4)
540-1040

Phillips Adapter Bracket Fasteners

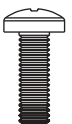

M4 x 12 mm (4)
504-9013

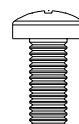

M5 x 12 mm (4)
520-1027

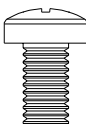

M6 x 12 mm (4)
520-1128

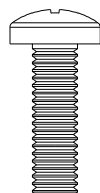

M6 x 20 mm (4)
520-9402

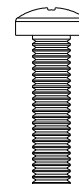

M5 x 25 mm (4)
520-9543



M4 x 25 mm (4)
504-1015

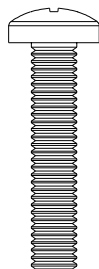

M6 x 30 mm (4)
510-9109

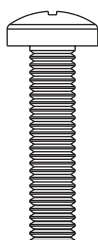

M6 x 25 mm (4)
520-1208

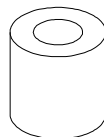

I.D. .26" (6.6 mm) (4)
540-1058



I.D. .203" (5.16 mm) (4)
540-1040

Installing Adapter Brackets

⚠ WARNING

- Tighten screws so adapter brackets are firmly attached. Do not tighten with excessive force. Overtightening can cause stress damage to screws, greatly reducing their holding power and possibly causing screw heads to become detached. Tighten to 40 in. • lb (4.5 N.M.) maximum torque.
- If screws don't get three complete turns in the screen inserts or if screws bottom out and bracket is still not tightly secured, damage may occur to screen or product may fail.
- This product is intended for indoor use only. Use of this product outdoors could lead to product failure and personal injury.

1 To prevent scratching the screen, set a cloth on a flat, level surface that will support the weight of the screen. Place screen face side down. If screen has knobs on the back, remove them to allow the adapter brackets to be attached. Place adapter brackets (**BB**) on back of screen, align to holes, and center on back of screen as shown below. Attach the adapter brackets to the back of the screen using the appropriate combination of screws, washers and spacers as shown in figure 1.1 and figure 1.2.

NOTE: Top and bottom holes must always be used.

Verify that all holes are properly aligned, and then tighten screws using a phillips screwdriver.

NOTE: If using security screws, tighten using security allen wrench (**CC**).

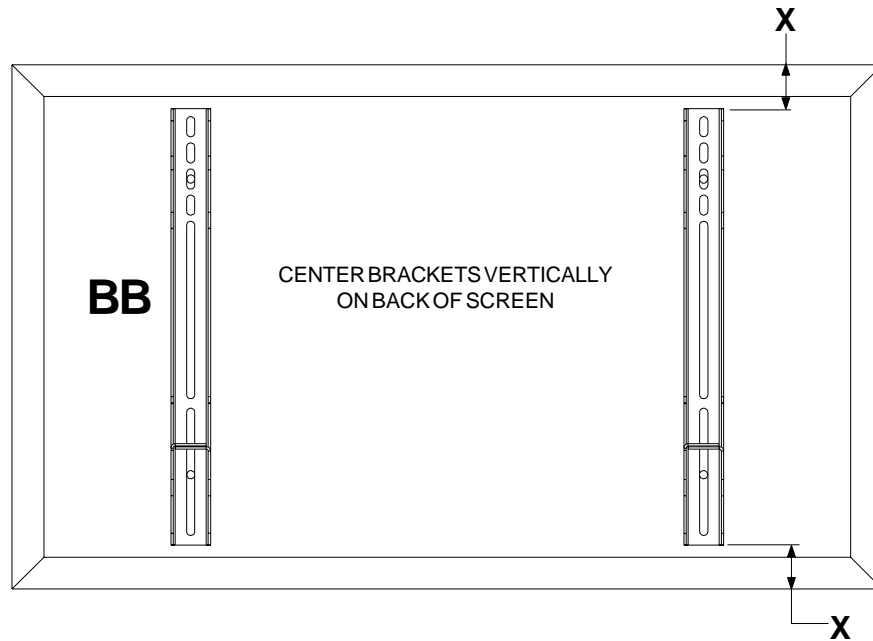

NOTE: "X" dimensions should be equal.

Notes:

- The number of fasteners used will vary, depending upon the type of screen.
- Washers and spacers may not be used, depending upon the type of screen.

NOTE: For **flat back screens** proceed to step 1-1. For **bump-out or recessed back screen** skip to step 1-2.

For Flat Back Screen

1-1

Refer to **Screen Compatibility Chart** to determine the proper fastener to use. Visit www.peerlessmounts.com/1 for a full screen compatibility chart for this mount.

Begin with the shortest length screw, hand thread through washer and adapter bracket into screen as shown below. Screw must make at least three full turns into the mounting hole and fit snug into place. Do not over tighten. If screw cannot make three full turns into the screen, select a longer length screw from the baffled fastener pack. Repeat for remaining mounting holes, level brackets and tighten screws.

NOTE: Spacers may not be used, depending upon the type of screen.

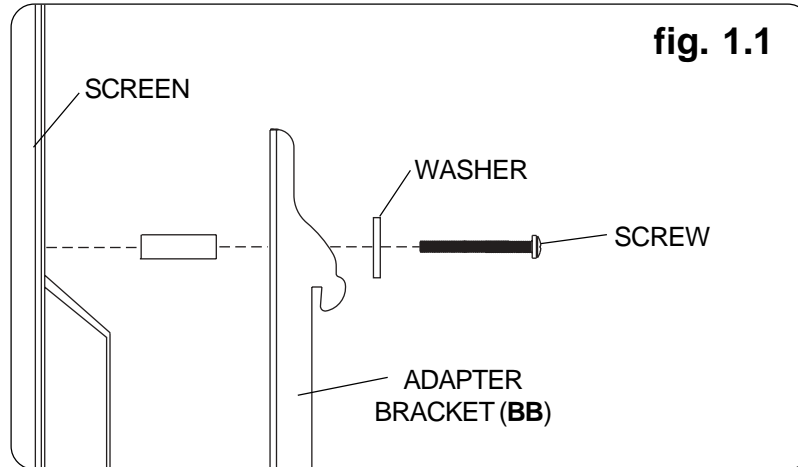

If you have any questions, please call Peerless customer care at **1-800-865-2112**.

For Bump-out or Recessed Back Screen

1-2

Refer to **Screen Compatibility Chart** to determine the proper fastener to use. Visit www.peerlessmounts.com/1 for a full screen compatibility chart for this mount.

Begin with longer length screw, hand thread through washer, adapter bracket and spacer in that order into screen as shown below. Screw must make at least three full turns into the mounting hole and fit snug into place. Do not over tighten. If screw cannot make three full turns into the screen, select a longer length screw from the baffled fastener pack. Repeat for remaining mounting holes, level brackets and tighten screws.

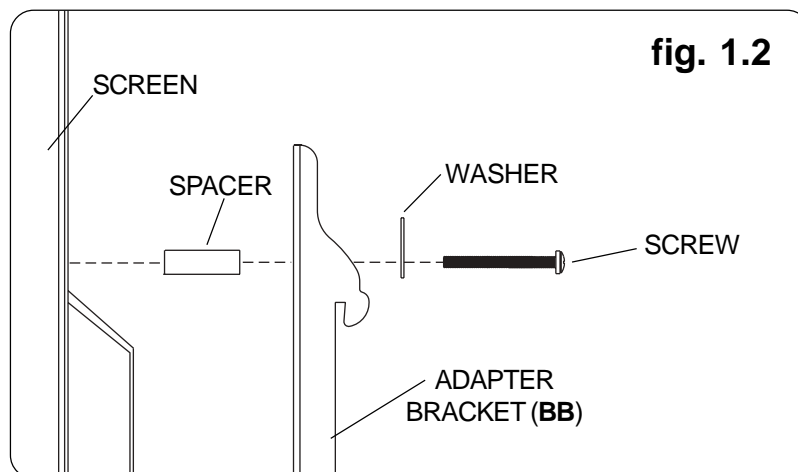

If you have any questions, please call Peerless customer care at **1-800-865-2112**.

Mounting and Removing Flat Panel Screen

⚠ WARNING

- Always use an assistant or mechanical lifting equipment to safely lift and position the plasma television.

Refer to mount instruction sheet for attachment of adapter bracket to mount.

- 2 Hook adapter brackets (**BB**) onto adapter bracket (**AA**), then slowly swing screen in as shown. Turn screws clockwise at least six times to prevent screen from being removed as shown in detail 1.

NOTE: Tighten screws using allen wrench (**CC**).

Screen can be adjusted horizontally if desired.

NOTE: To lock the screen down, tighten screws to adapter bracket as shown in detail 1.

To remove screen from mount, loosen screws, swing screen away from mount, and lift screen off of mount.

