

TECHNICAL DATA SHEET - Universal Adapter Bracket for 22" - 46" Flat Panel Screens



MODELS: PLP-UNM, PLP-UNMP, PLP-UNM-S, PLP-UNMP-S

The Universal Adapter Bracket offers unparalleled compatibility with medium to large sized plasma and LCD flat panel screens 22" - 46". The heavy duty plate and brackets hold up to 150 lb and quickly and easily attach to most Peerless flat panel mounts. Includes pre-sorted fastener kit with all necessary screen hardware and both shallow and deep brackets to attach to screens with a component box or tuner on the back.

Features:

- Universal plate fits virtually any 22" to 46" screen
- Compatible with most Peerless flat panel mounts: PLA50, PLA60, PLAV60, PLB, PLCM-1, PLCM-1CP, PLT, PLCT, COL, MDJ (mounts sold separately)
- Security models available provide effective theft deterrence
- Plate and brackets hold up to 150 lb
- Scratch resistant fused epoxy finish
- Pre-sorted fastener pack for quick and easy assembly
- Heavy gauge cold rolled steel construction
- Available in black or silver

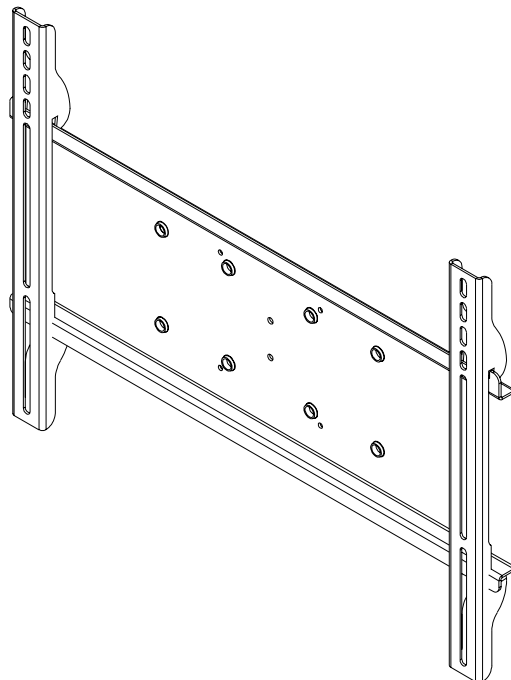

Dimensions:

Weight:
7.2 lb (3.3 kg)

Shipping weight:
8.9 lb (4.0 kg)

Maximum Load Capacity:
150 lb (68 kg)

Shipping Carton dimensions:
L= 19.75 in (502 mm)
W= 7.75 in (197 mm)
H= 3.625 in (92 mm)

ARCHITECTS SPECIFICATIONS

The Universal Adapter Bracket shall be a Peerless model _____ and shall be located where indicated on the plans. It shall be constructed of heavy gauge steel. The finish shall be scratch resistant black or silver fused epoxy. Assembly and installation shall be done according to instructions provided by the manufacturer.

TECHNICAL DATA SHEET

MODELS: PLP-UNM, PLP-UNMP, PLP-UNM-S, PLP-UNMP-S

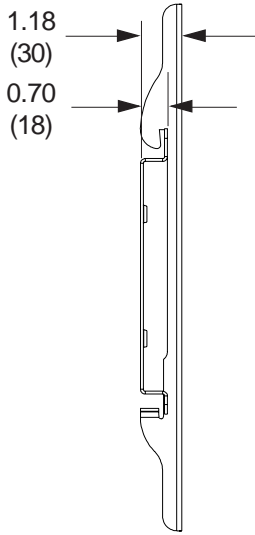

SIDE VIEW

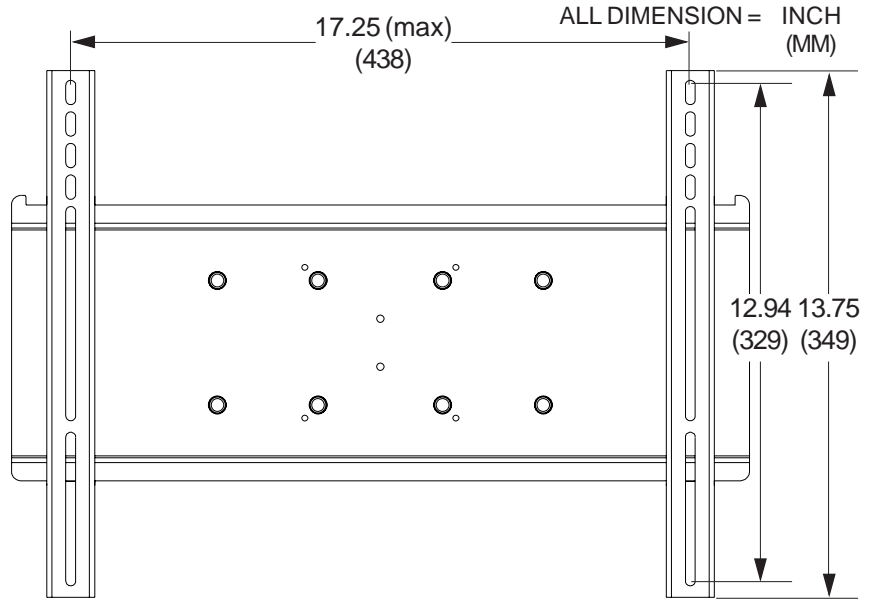

FRONT VIEW

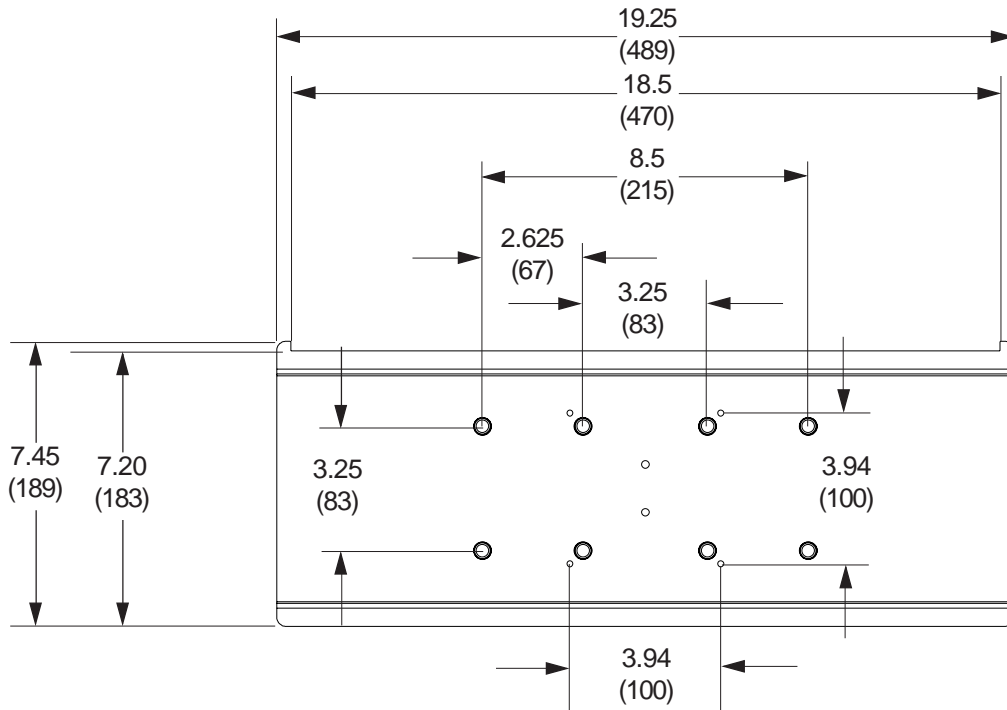

ADAPTER BRACKET DETAIL