



PARAMOUNT™ by Peerless

## LCD Ceiling Mount

For 15" to 37" LCD Screens

### MODELS

#### UNIVERSAL MODELS

WITH 9.7" - 13.9" EXTENSION::

Security Fasteners\*

<b>PC932A</b>	Black
<b>PC932A-S</b>	Silver
<b>PC932A-W</b>	White

#### UNIVERSAL MODELS

WITH 13.78" - 21.89" EXTENSION:

Security Fasteners\*

<b>PC932B</b>	Black
<b>PC932B-S</b>	Silver
<b>PC932B-W</b>	White

#### UNIVERSAL MODELS

WITH 20.24" - 34.02" EXTENSION:

Security Fasteners\*

<b>PC932C</b>	Black
<b>PC932C-S</b>	Silver
<b>PC932C-W</b>	White

### SCREEN ADAPTER

#### UNIVERSAL MODELS:

Includes universal screen adapter to accommodate VESA® 75/100/200 x 100 and 200 x 200 mm mounting holes

### SPECIFICATIONS

#### DIMENSIONS: (W x H x D)

PC932A(-S)(-W):	6.5" x 9.8"-13.9" x 6.5" (16.5 x 24.8-35.3 x 16.5 cm)
PC932B(-S)(-W):	6.5" x 13.78"-21.89" x 6.5" (16.5 x 35-55.6 x 16.5 cm)
PC932C(-S)(-W):	6.5" x 20.24"-34.02" x 6.5" (16.5 x 51.4-86.4 x 16.5 cm)

**TILT:** +15/-5°

**SWIVEL:** 360°

**MAX LOAD:** 80 lb (36.2 kg)

#### SHIP WEIGHT:

PC932A(-S)(-W):	6.1 lb (2.7 kg)
PC932B(-S)(-W):	6.7 lb (3 kg)
PC932C(-S)(-W):	7.6 lb (3.4 kg)

#### MOUNTING

**SURFACES:** Wood joist and concrete



■ VESA® 75, 100, 200 x 100 and 200 x 200 mm compliant

■ Three adjustable extension lengths:  
PC930A models - 9.8" - 13.9"  
PC930B models - 13.78" - 21.89"  
PC930C models - 20.24" - 34.02"

■ Continuous tilt of +15/-5° with optional lock in 5° increments

■ 360° swivel provides limitless screen placement opportunities

■ Internal cable management within extension channels for clean, clutter-free appearance

■ Safety catch designed into extension channels to ensure user and equipment safety

\* Includes theft resistant hardware for attaching screen to mount

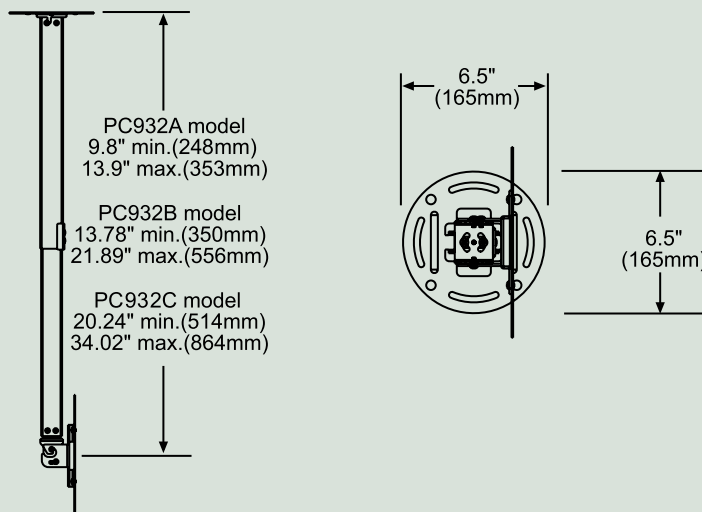

To verify mount compatibility with any LCD, plasma, or projector model use MountFinder™ at [www.peerlessmounts.com](http://www.peerlessmounts.com) 800.865.2112