



SmartMount® Articulating Wall Arm

For 37" to 71" Flat Panel Screens

MODELS

Universal Models:

Includes standard hardware (hex or Phillips) for attaching screen to mount

- SA771PU** High gloss black
- SA771PU-S** High gloss silver

Dedicated Models:

Includes standard hardware (hex or Phillips) for attaching screen to mount
Requires Screen Adapter to be Purchased Separately*

- SA771P** High gloss black

* Dedicated adapter plates come in flat black and include security fasteners

SCREEN ADAPTER



Mounting pattern

Universal Models: 44.45" W x 26.03" H
(1129 x 661 mm)



VESA® pattern

Universal Models: up to 800 x 600 mm

Dedicated Models: Requires screen-specific PLP or LC adapter to be purchased separately

SPECIFICATIONS



Distance from wall

Universal Models: 4.43"-27.55" (113-700 mm)
Dedicated Models: 2.83"-25.83" (72-656 mm)



Tilt | Swivel | Roll

+15/-5° | ±90° | ±5°



Max load

200 lb (91 kg)

Product Dimensions (W x H x D)

Universal Models: 34.38" x 20.23" x 4.43"-27.55"
(873 x 514 x 113-700 mm)
Dedicated Models: 19.2" x 20.23" x 2.83"-25.83"
(488 x 514 x 72-656 mm)

Mounting Surfaces

Wood stud, concrete, cinder block and metal stud
(Metal stud accessory required)

Ship Weight

Universal Models: 68 lb (31 kg)
Dedicated Models: 63 lb (29 kg)

CERTIFICATIONS



ACCESSORIES



ACC925: Security Fasteners pg# 132



ACC415: Metal stud Accessory pg# 130

- Dual Arm construction for added strength and smooth motion on larger screens
- Arms extends up to 27.53" (699 mm) from wall (including thickness of screen adapter)
- Minimalistic wall plate footprint for increased wall access and improved aesthetic
- Horizontal adjustment up to 4.5" (114 mm) for perfect screen placement
- Integrated Cable Management provides ample area to run cables to complete a professional and discrete installation
- One-touch tilt allows adjustment of +15°/-5° without the use of tools
- ±5° roll aid in screen leveling
- Screen can be rotated from portrait to landscape without removing the screen
- ±0.5" vertical adjustment for fine tuning screen position

Universal Models

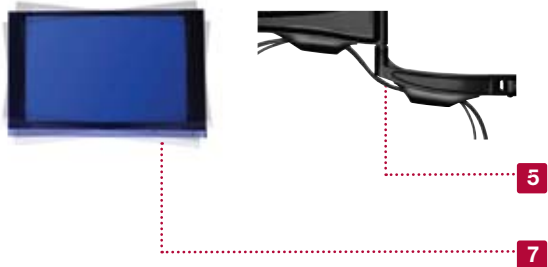
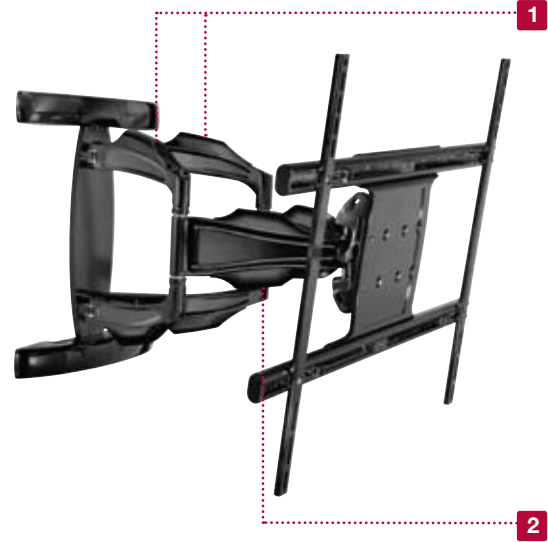

TECHNICAL DRAWINGS

For expanded product information and technical data visit www.peerlessmounts.com

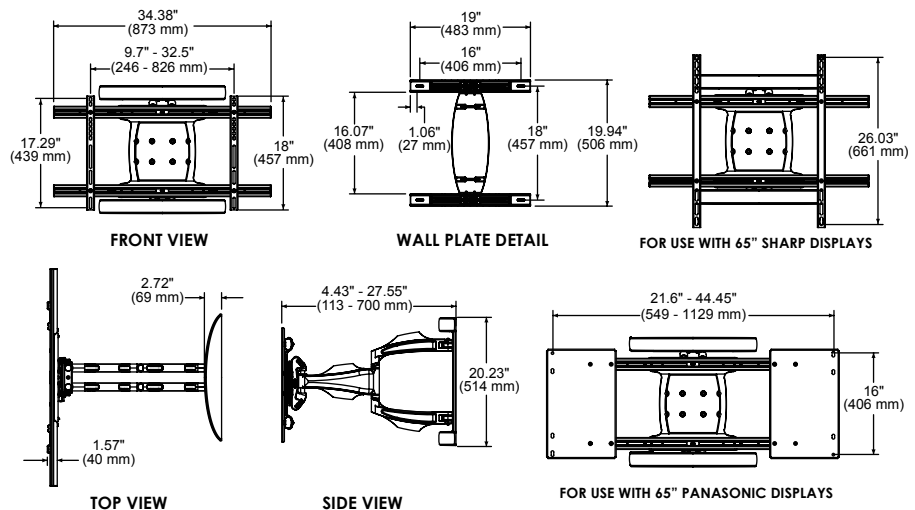

To verify mount compatibility with any LCD, plasma or projector model use MountFinder™ at www.peerlessmounts.com



CLICK: www.peerlessmounts.com



CALL: 800.865.2112



FAX: 708.865.2941