

# PLA Series Articulating Wall Arm

For 32" to 50" Flat Panel Screens



FLAT PANEL MOUNTS

1. Arm extends up to 29.3" (744 mm) from wall (plus thickness of adapter plate)
2. Three pivot points with up to 180° swivel
3. +10/-5° of tilt
4. ±7° roll to level screen horizontally
5. Universal models adapt to screens with mounting holes up to 28.7"W x 17.05"H (729 x 433 mm)
6. Includes mesh cord sheath and cable ties to neatly manage cables and cords
7. Five horizontal arm positions at 2.6" (66 mm) centers for flexible lateral screen placement

Universal Models



Dedicated Models

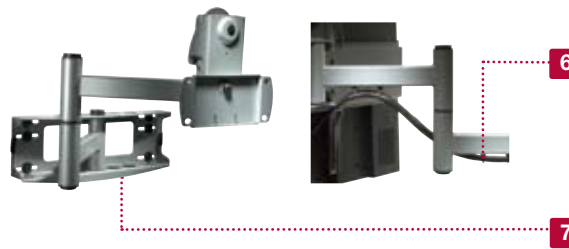

For expanded product information and technical data visit [www.peerlessmounts.com](http://www.peerlessmounts.com)

## TECHNICAL DRAWINGS

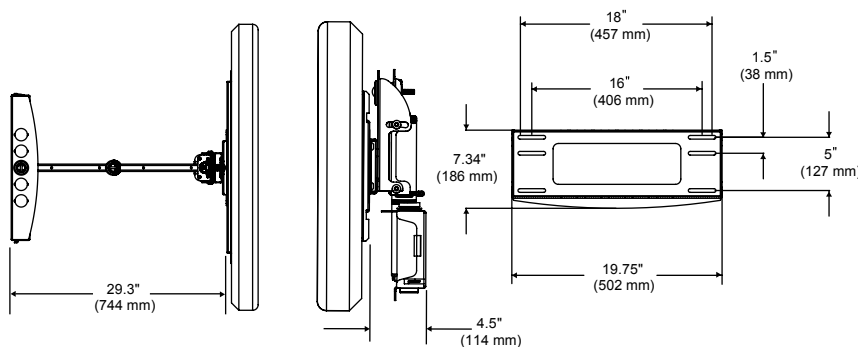

## MODELS

### Universal Models:

Includes theft resistant hardware for attaching screen to mount

<b>PLA50-UNL</b>	Black
<b>PLA50-UNL-S</b>	Silver

Includes standard hardware (hex or Phillips) for attaching screen to mount

<b>PLA50-UNLP</b>	Black
<b>PLA50-UNLP-S</b>	Silver
<b>PLA50-UNLP-GB</b>	High gloss black
<b>PLA50-UNLP-GS</b>	High gloss silver

### Dedicated Models:

Includes theft resistant hardware for attaching screen to mount  
Screen adapter purchased separately\*

<b>PLA50</b>	Black
<b>PLA50-S</b>	Silver

\* Dedicated adapter plates come in flat black and include security fasteners

## SCREEN ADAPTER



### Mounting pattern

Universal Models: 28.7" W x 17.05" H (729 x 433 mm)

Dedicated Models: Requires screen-specific adapter to be purchased separately

## SPECIFICATIONS



### Distance from wall

Universal Models: 5.6"-30.4" (142-772 mm)

Dedicated Models: 4.5"-29.3" (114-744 mm)



### Tilt | Swivel | Roll

+10/-5° | ±90° | ±7°



### Max load

150 lb (68 kg)

### Product Dimensions (W x H x D)

Universal Models: 30.7" x 19.1" x 5.6"-30.4" (780 x 486 x 142-772 mm)

Dedicated Models: 19.75" x 18.7" x 4.5"-29.3" (501 x 474 x 114-744 mm)

### Mounting Surfaces

Wood stud, concrete and metal stud (Metal stud accessory required)

### Ship Weight

Universal Models: 43 lb (19.5 kg)

Dedicated Models: 28.5 lb (12.9 kg)

## CERTIFICATIONS



## ACCESSORIES



**WSP716:** (Triple stud on 16" centers)  
Metal Stud Wall Plate ..... pg# 130



**WSP724:** (Triple stud on 16"-24" centers)  
Metal Stud Wall Plate ..... pg# 130

To verify mount compatibility with any LCD, plasma or projector model use MountFinder™ at [www.peerlessmounts.com](http://www.peerlessmounts.com)

**CLICK:** [www.peerlessmounts.com](http://www.peerlessmounts.com)

**CALL:** 800.865.2112

**FAX:** 708.865.2941