

# TECHNICAL DATA SHEET - Articulating Wall Arm for 32" - 65" Plasma and LCD Flat Panel Screens



**MODELS: PLA50, PLA50-S, PLA50-UNL, PLA50-UNL-S, PLA50-UNLP, PLA50-UNLP-S, PLA50-UNLP-GB, PLA50-UNLP-GS**

Offer the best view in the room with ability to swing, tilt or articulate the most popular sizes of plasma and LCD screens. Self-lubricating bushings enable the arms to smoothly extend, while adjustable tilt and pivot position the screen to the optimal viewing angle. The **PLA50** offers versatility for the most popular sizes of screen in a wide range of installations in lobbies, hotel rooms, boardrooms, public displays or home theaters.

### **Features:**

- For 32" to 65" plasma and LCD screens
- New look and functionality
- Roll feature allows for easy screen leveling
- Folds flat against the wall
- Cord management keeps cords organized and out of sight
- Comes in black, silver, glossy black or glossy silver
- +10°/-5° tilt
- Up to 180° pivot
- +/-7° roll to level screen horizontally at any position
- Extends out to 29.3", retracts to 4.5" (plus thickness of required adapter plate)
- Includes mesh cord sheath and cable ties to neatly manage cords
- Mounts to two wood studs or concrete
- Universal models adapt to screens with up to 28.7" wide x 17" high mounting inserts

### **Accessories:**

- Multi-channel speaker mount (MSA-101)
- Wire management channel (ACC 924/ ACC 926)
- PLP model adapter plates
- External Wall Plate (WSP716, WSP716-S, WSP724, WSP724-S) (Metal Stud not evaluated by UL)

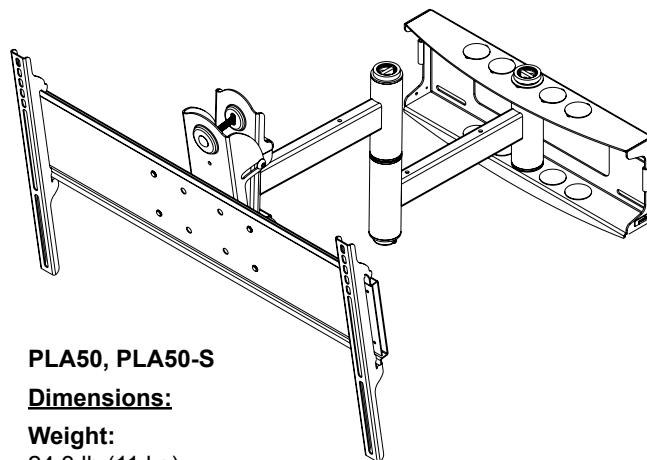

### **PLA50, PLA50-S**

#### **Dimensions:**

**Weight:**  
24.3 lb (11 kg)

**Shipping weight:**  
28.5 lb (12.9 kg)

**Maximum Load Capacity:**  
150 lb (68 kg)

#### **Shipping Carton dimensions:**

L= 23.125 in (587 mm)  
W= 17.125 in (435 mm)  
H= 7.375 in (187 mm)

### **PLA50-UNL, PLA50-UNL-S PLA50-UNLP, PLA50-UNLP-S, PLA50-UNLP-GB, PLA50-UNLP-GS**

#### **Dimensions:**

**Weight:**  
36.8 lb (17 kg)

**Shipping weight:**  
42.9 lb (19.5 kg)

**Maximum Load Capacity:**  
150 lb (68 kg)

#### **Shipping Carton dimensions:**

L= 31.5 in (800 mm)  
W= 17.125 in (435 mm)  
H= 8.625 in (219 mm)

## ARCHITECTS SPECIFICATIONS

The Articulating Wall Arm shall be a Peerless model \_\_\_\_\_ and shall be located where indicated on the plans. It shall be constructed of heavy gauge cold rolled steel with 10° adjustable forward and 5° backward tilt. It shall feature +/-7 degrees of roll. The finish shall be scratch resistant Black, Silver, Glossy Black or Glossy Silver Fused Epoxy. Assembly and installation shall be done according to instructions provided by the manufacturer.

**TECHNICAL DATA SHEET**

**MODELS: PLA50, PLA50-S, PLA50-UNL, PLA50-UNL-S, PLA50-UNLP, PLA50-UNLP-S, PLA50-UNLP-GB, PLA50-UNLP-GS**

**Note:** All dimensions are shown as inch (mm).

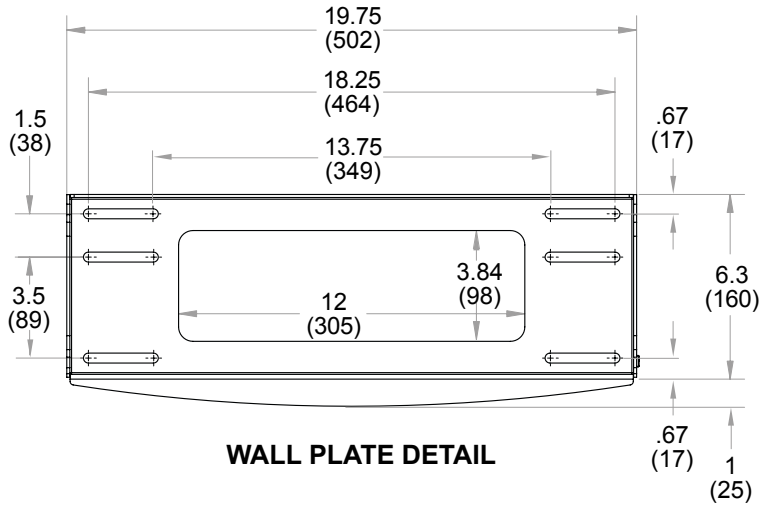

**WALL PLATE DETAIL**

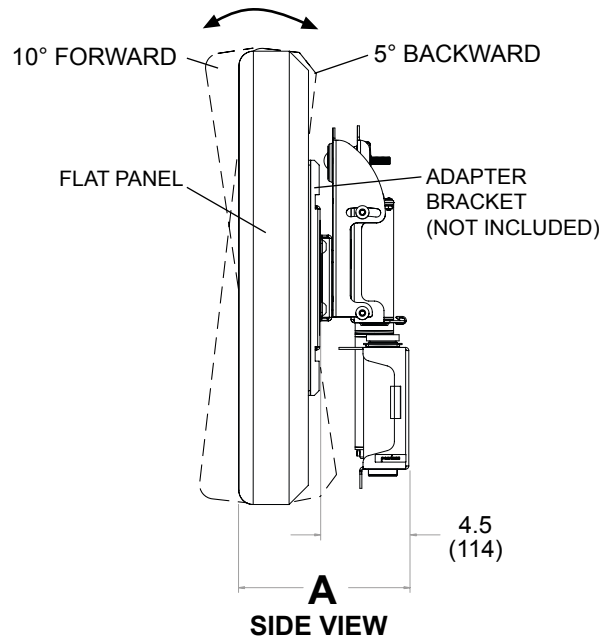

**SIDE VIEW**

**A = DEPTH OF FLAT PANEL + DEPTH OF ADAPTER BRACKET\* + 4.5"**  
 \*For depth of adapter bracket refer to PLP TD sheet

CF = CENTER OF FLAT PANEL

CA = CENTER OF ADAPTER BRACKET

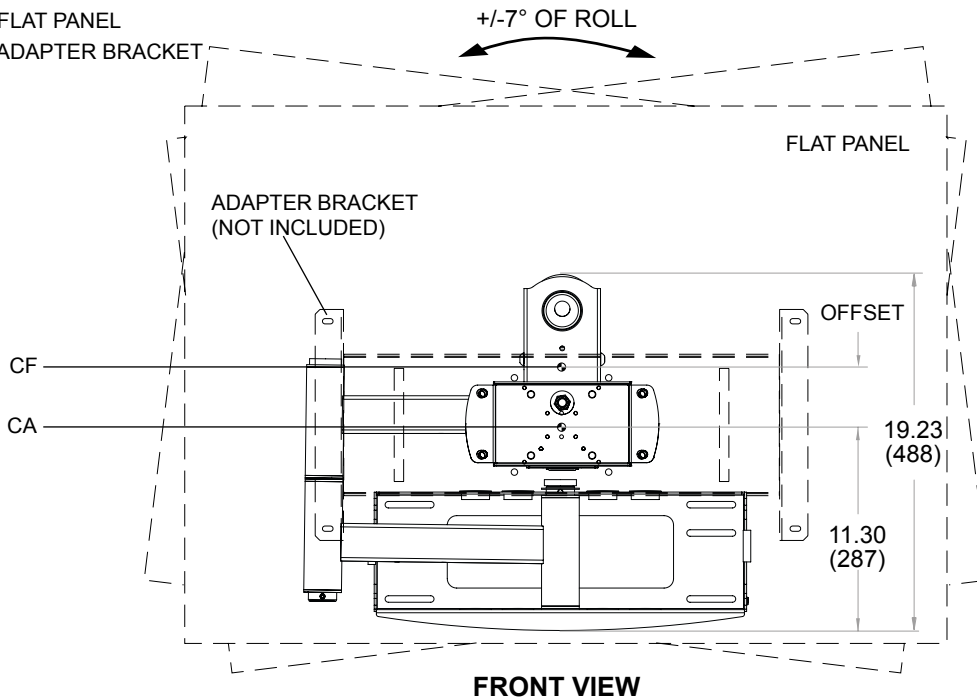

**FRONT VIEW**

THE MINIMUM FLAT PANEL HEIGHT THAT WOULD FULLY HIDE THE MOUNT IS (10.96"(253 MM) + OFFSET\*) X 2.

\*For offset of adapter bracket refer to PLP TD sheet

**TECHNICAL DATA SHEET**

**MODELS: PLA50, PLA50-S, PLA50-UNL, PLA50-UNL-S, PLA50-UNLP, PLA50-UNLP-S, PLA50-UNLP-GB, PLA50-UNLP-GS**

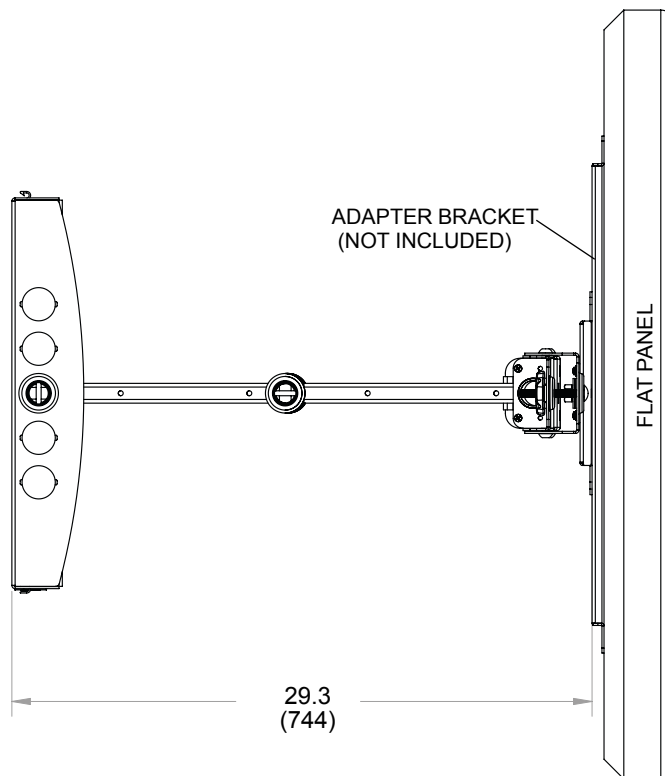

**TOP VIEW (A)**

THE MAXIMUM FLAT PANEL WIDTH THAT WOULD ALLOW A MOUNTED FLAT PANEL SCREEN A FULL 180 DEGREE SWIVEL IS 46" (1168 mm)

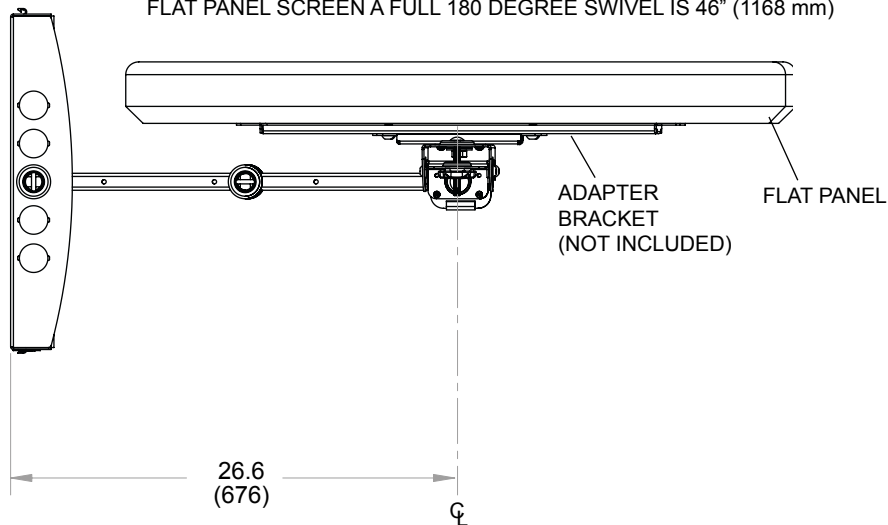

**TOP VIEW (B)**