

TECHNICAL DATA SHEET - Multichannel Speaker Mount

peerless®

MODEL: MSA-301, MSA-301S

The **MSA-301** will allow the customer to mount a specific set of left, center, and right speakers from Atlantic Technology to our PLA mounts. The specific speakers that will work with this product are Atlantic Technology model numbers FS-3200 C and FS-3200 LR, where the C stands for center and the LR stands for left and right.

Dimensions:

Weight:

22.00 lb (10.0 kg)

Shipping weight:

23.50 lb (10.7 kg)

Maximum Load Capacity:

50 lb (22.68 kg)

Shipping Carton dimensions:

L = 38.50 in (978 mm)

W = 19.50 in (495.3 mm)

H = 3.75 in (95.3 mm)

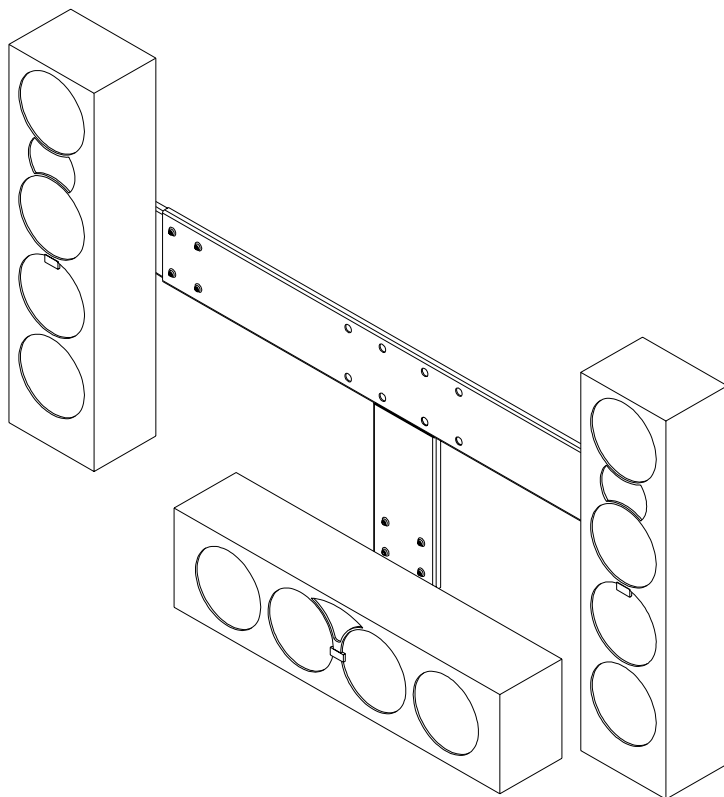

NOTE: For use with FS-3200 C and FS-3200 LR speakers only

ARCHITECTS SPECIFICATIONS

The Multichannel Speaker Mount shall be a Peerless model _____ and shall be located where indicated on the plans. It shall be constructed of heavy gauge cold rolled steel and finished with scratch resistant black or silver fused epoxy finish. Assembly and installation shall be done according to instructions provided by the manufacturer.

Peerless Industries, Inc.

3215 W. North Ave. Melrose Park, IL 60160
708-865-8870 800-865-2112 Fax 708-865-2941

www.peerlessmounts.com

ISSUED: 02-12-07 SHEET NO: 087-9512-1

TECHNICAL DATA SHEET

MODEL: MSA-301, MSA-301S

All dimensions = inch (mm)

Top View

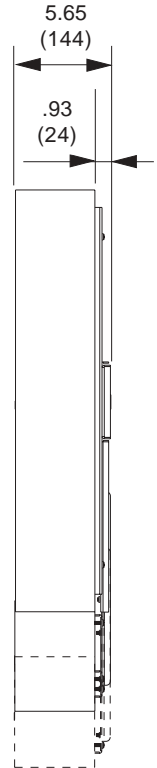
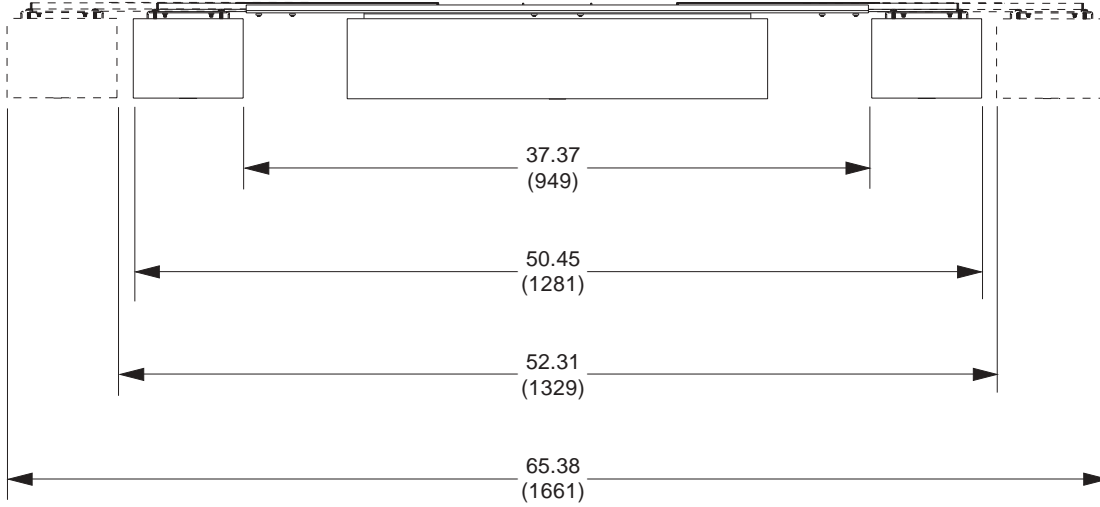

Side View

Front View

