

**IMPORTANT!** Read entire instruction sheet before you start assembly and installation.

## Parts List

PART #	QTY.	DESCRIPTION
A 600-0025	4	leveler feet

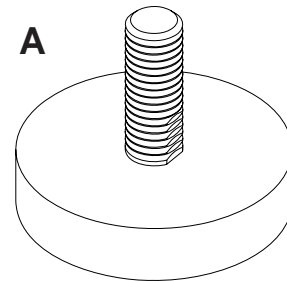

- 1** Remove Plasma TV from cart prior to setting cart down on its back side. Remove existing casters from the bottom of Plasma Cart.

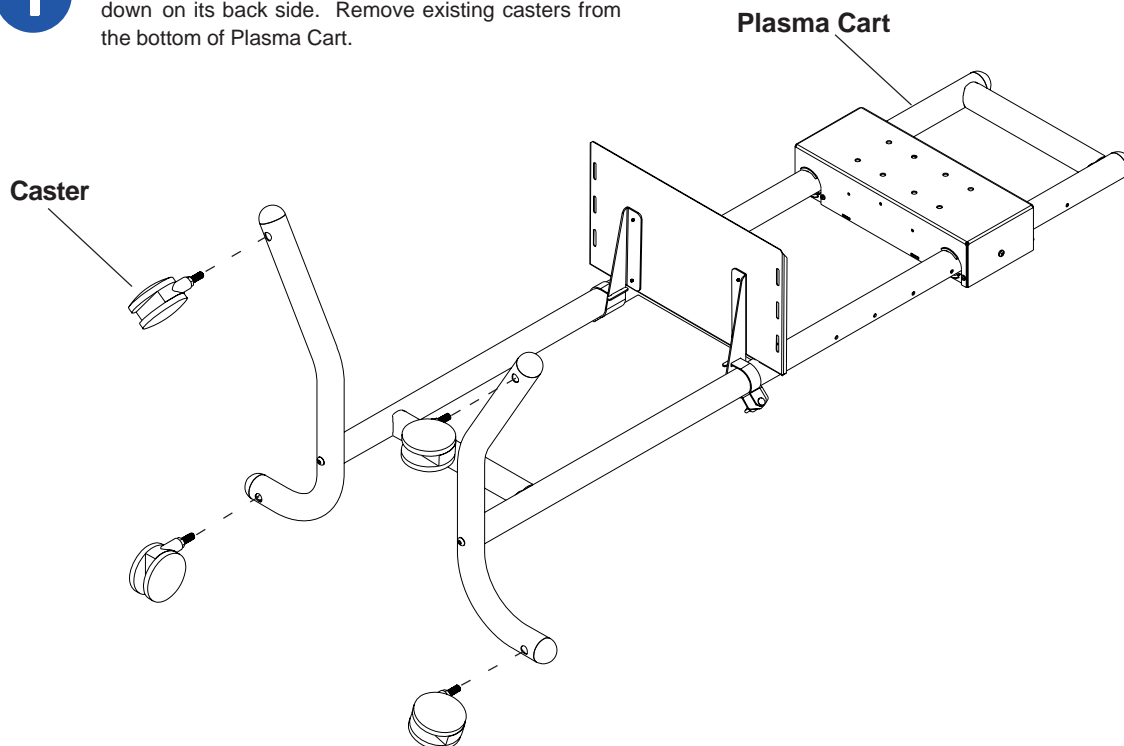

**2**

Screw four leveler feet (A) to bottom of plasma cart.  
**Note:** Turn leveler feet equally to level cart.

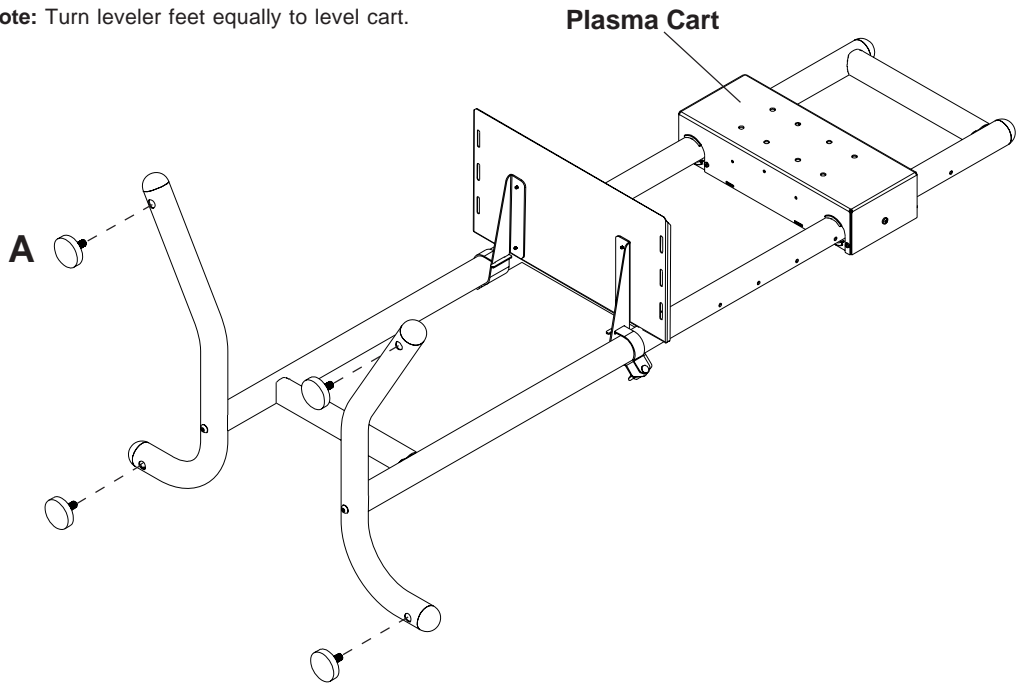

Stand Plasma Cart up and check cart for level. Adjust leveler feet by hand or using a wrench.

