

TECHNICAL DATA SHEET - Adjustable Metal Shelf



MODEL: ACC313

The Adjustable Metal Shelf is designed to attach to the Flat Panel TV Cart and Flat Panel TV Stand. Adjustable Metal Shelf can be used for a variety of A/V equipment and accessories.

Features:

- Heavy gauge cold rolled steel construction
- Scratch resistant black fused epoxy
- Vertical height adjustability
- Quick release knobs for easy height adjustment

Dimensions:

Shipping weight:
10.5 lb (4.7 kg)

Max Load Capacity:
50 lb (23 kg)

Shipping Carton dimensions:
L= 25.5 in. (648 mm)
W= 14.5 in. (368 mm)
H= 5.75 in. (146 mm)

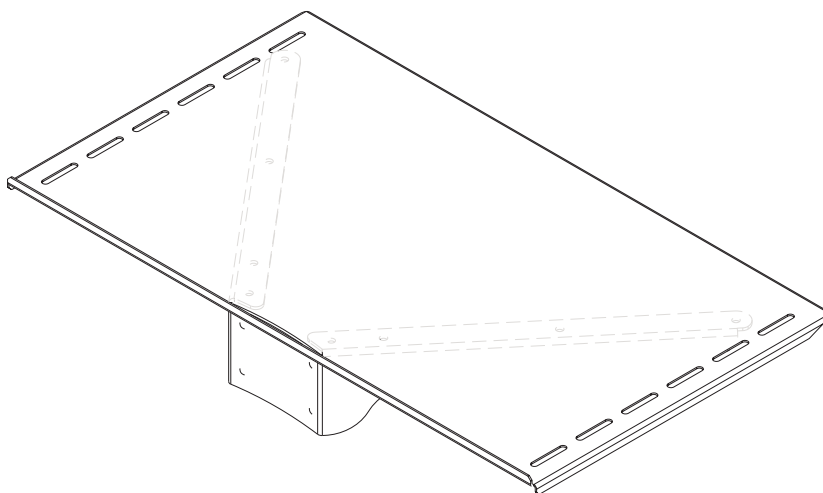

ARCHITECTS SPECIFICATIONS

Adjustable Metal Shelf shall be a Peerless model **ACC313** and shall be installed where indicated on the plans. It shall be constructed of heavy gauge cold rolled steel and finished with scratch resistant Black Fused Epoxy. Assembly and installation shall be done according to instructions provided by the manufacturer.

TECHNICAL DATA SHEET

MODELS: ACC313

ALL DIMENSION = INCH
(MM)

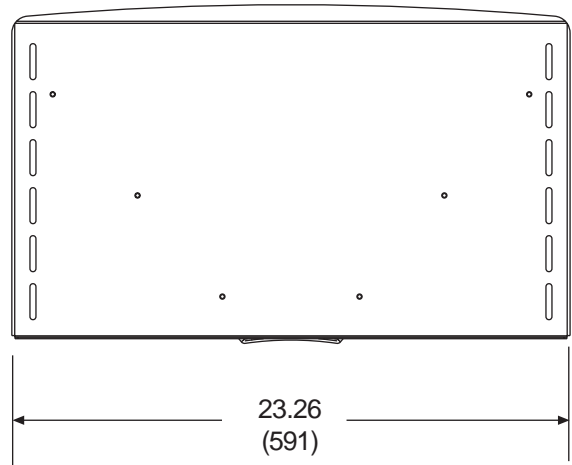

Top View

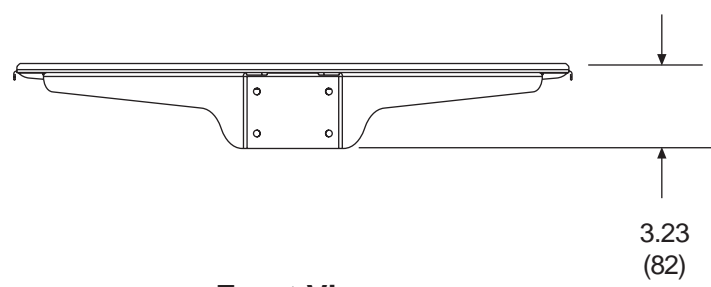

Front View

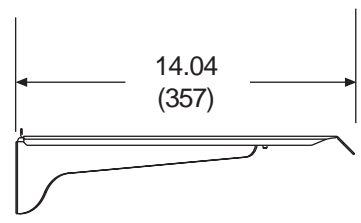

Side View