

TECHNICAL DATA SHEET - Video Conferencing Shelf

peerless[®]
Solid Solutions - Solid Support™

MODEL: ACC319

The Video Conferencing Shelf designed to attach to the Flat Panel TV Cart. Shelf can be used for a variety of A/V equipment and accessories.

Features:

- 25 lb capacity
- Holds smallest to largest video conferencing cameras
- Heavy gauge cold rolled steel construction
- Scratch resistant black fused epoxy
- Vertical height adjustability

Dimensions:

Shipping weight:

12.8 lb (5.8 kg)

Max Load Capacity:

25 lb (11 kg)

Shipping Carton dimensions:

L= 30 in. (762 mm)

W= 21 in. (533 mm)

H= 2 in. (51 mm)

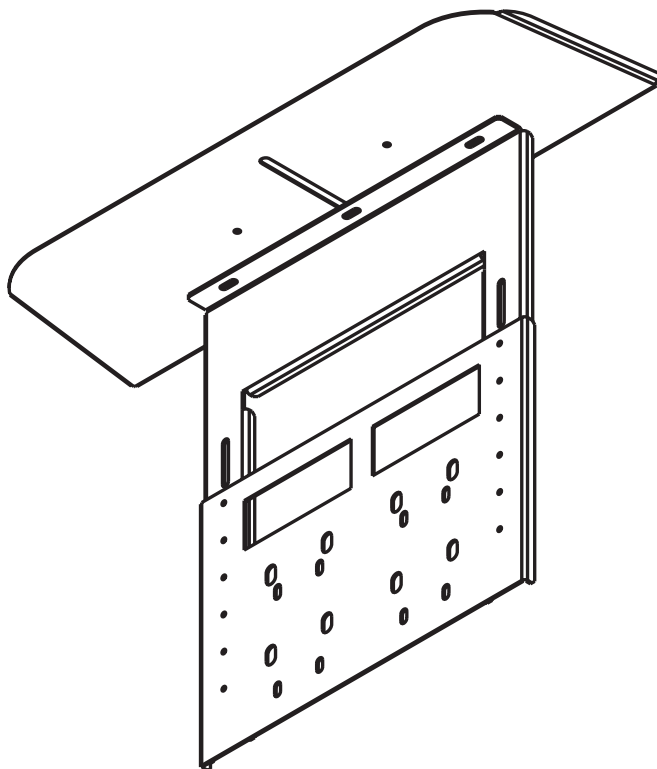

ARCHITECTS SPECIFICATIONS

Video Conferencing Shelf shall be a Peerless model **ACC319** and shall be installed where indicated on the plans. It shall be constructed of heavy gauge cold rolled steel and finished with scratch resistant Black Fused Epoxy. Assembly and installation shall be done according to instructions provided by the manufacturer.

Peerless Industries, Inc.
3215 W. North Ave. Melrose Park, IL 60160
708-865-8870 800-865-2112 Fax 708-865-2941
www.peerlessmounts.com

ISSUED: 02-06-07 SHEET NO: 009-9530-1

©2007 Peerless Industries, Inc. All rights reserved.
Peerless is a registered trademark of Peerless Industries, Inc.

All other brand and product names are trademarks or registered trademarks of their respective owners.

TECHNICAL DATA SHEET

MODEL: ACC319

ALL DIMENSION = INCH
(MM)

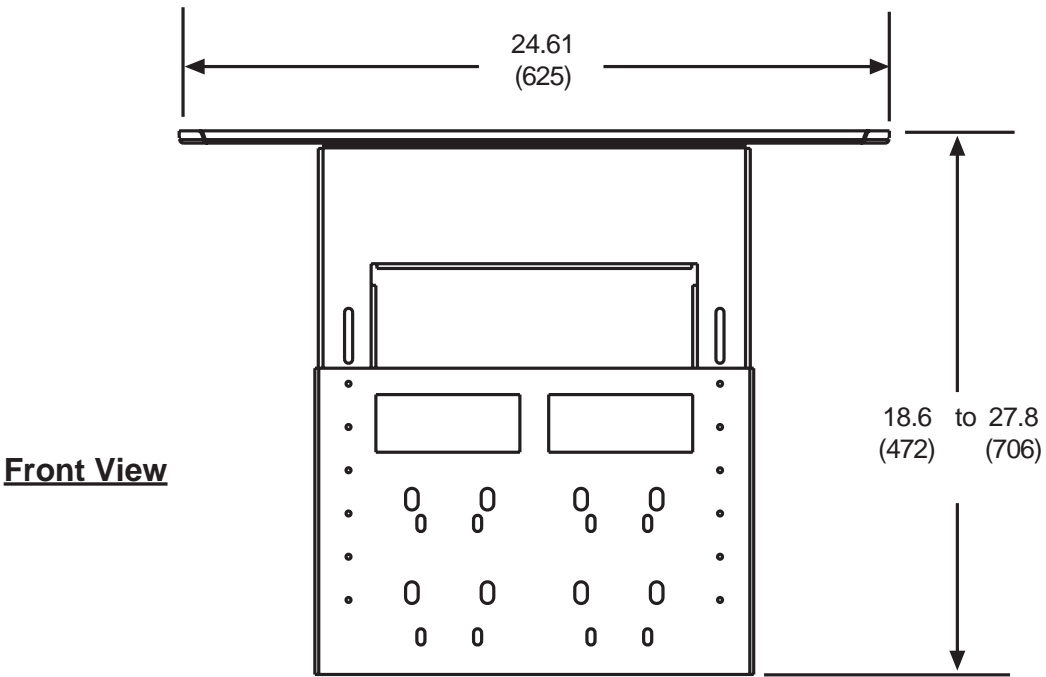

Side View

