

# TECHNICAL DATA SHEET - Glass Shelf



**MODELS: ACC317, ACC317-S, ACC318, ACC318-GB, ACC318-S**

The ACC317, ACC317-S, ACC318, ACC318-GB, ACC318-S

### Features:

- Colors: black with clear glass shelf, silver with clear glass shelf, black with tinted glass shelf, piano black with tinted glass shelf, or silver with tinted glass shelf
- same triangular shelf as FST550P
- 50 lb maximum weight capacity per shelf
- includes bracket and hardware

### Dimensions:

#### **Weight:**

9.25 lbs (4.2 kg)

#### **Shipping weight:**

14.2 lb (6.44 kg)

#### **Maximum Load Capacity:**

50 lb (22.7 kg) per shelf

#### **Shipping Carton dimensions:**

**L** = 35.75 in (908 mm)

**W** = 22.5 in (572 mm)

**H** = 4.5 in (114 mm)

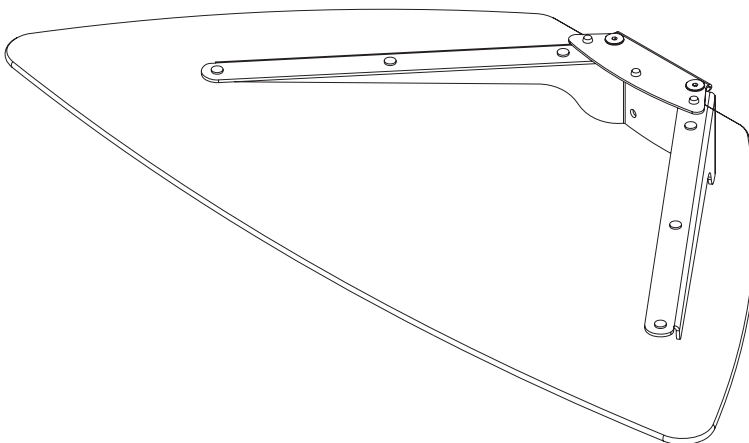

## ARCHITECTS SPECIFICATIONS

The Shelf shall be a Peerless model **ACC317, ACC317-S, ACC318, ACC318-GB, ACC318-S** and shall be located where indicated on the plans. Assembly and installation shall be done according to instructions provided by the manufacturer.

### **Peerless Industries, Inc.**

3215 W. North Ave. Melrose Park, IL 60160  
708-865-8870 800-865-2112 Fax 708-865-2941

[www.peerlessmounts.com](http://www.peerlessmounts.com)

**ISSUED: 10-02-06 SHEET NO: 120-9516-3 03-05-07**

©2007 Peerless Industries, Inc. All rights reserved.  
Peerless is a registered trademark of Peerless Industries, Inc.

All other brand and product names are trademarks or registered trademarks of their respective owners.

## TECHNICAL DATA SHEET

**MODEL:** ACC317, ACC317-S, ACC318, ACC318-GB, ACC318-S

All dimensions = inch (mm)

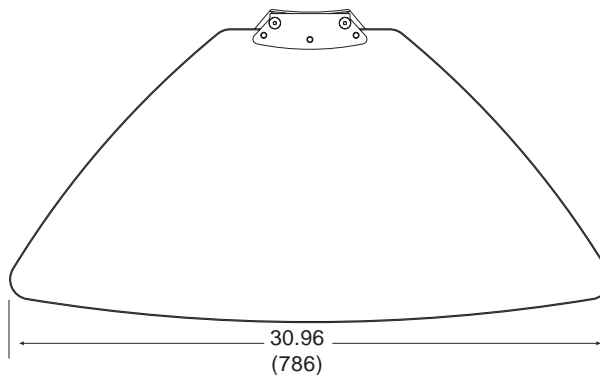
**NOTE:** For max. height of shelf refer to main instruction sheet.

Top View



Front View

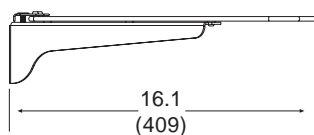

Side View