

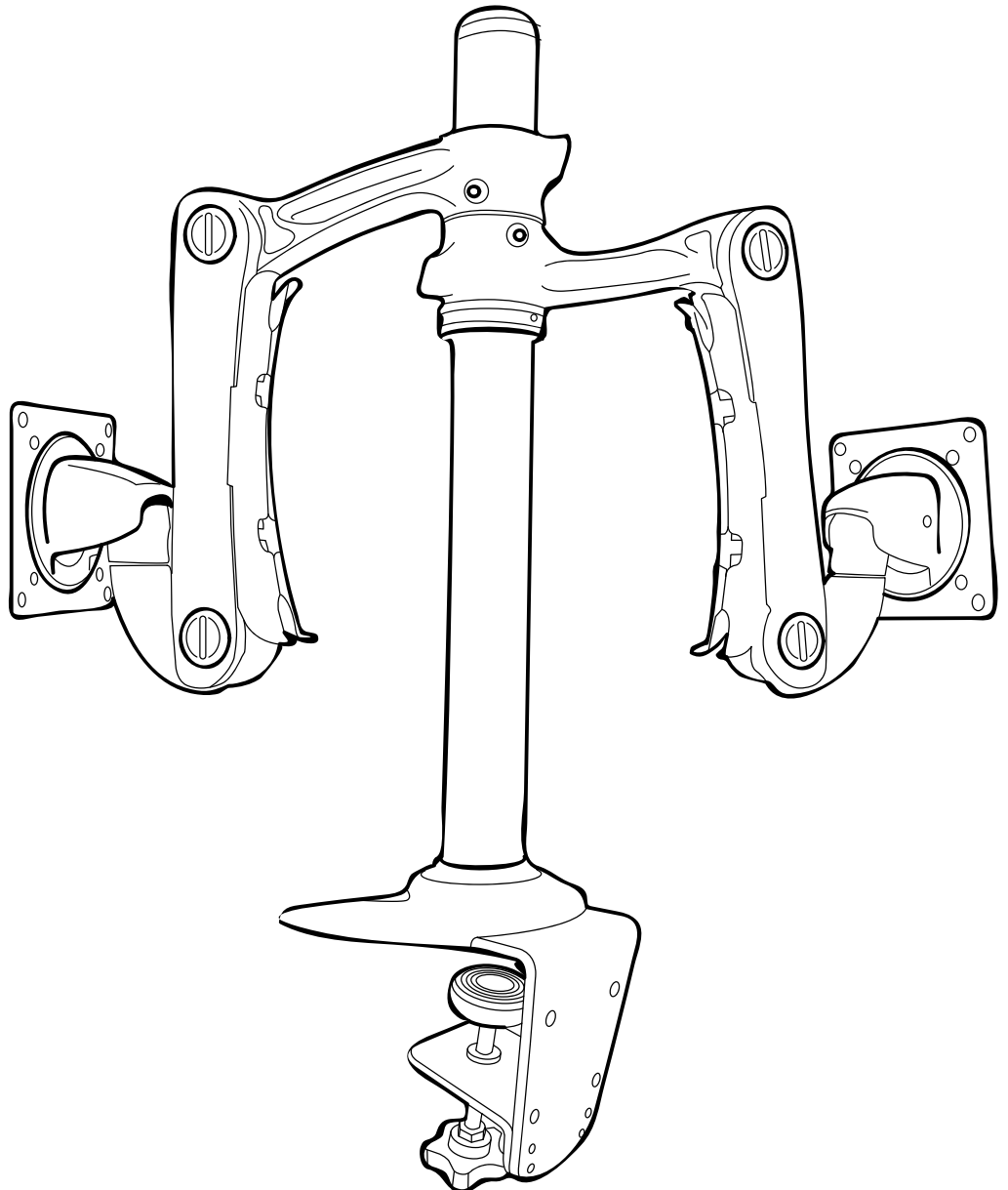

Installation and Assembly: Dual Desktop Two-Link Pole for 15" - 24" LCD monitors

Models: LCT-A1B4C, LCT-A1B4H



Max Load Capacity per Arm: 17.6 lb (8 kg)

NOTE: Read entire instruction sheet before you start installation and assembly.

⚠ WARNING

- Do not begin to install your Peerless product until you have read and understood the instructions and warnings contained in this Installation Sheet. If you have any questions regarding any of the instructions or warnings, please call Peerless customer care at 1-800-865-2112.
- This product should only be installed by someone of good mechanical aptitude, has experience with basic building construction, and fully understands these instructions.
- Make sure that the supporting surface will safely support the combined load of the equipment and all attached hardware and components.
- Never exceed the Maximum Load Capacity. See page one.
- Always use an assistant or mechanical lifting equipment to safely lift and position equipment.
- Tighten screws firmly, but do not overtighten. Overtightening can damage the items, greatly reducing their holding power.
- Be sure to use designated fasteners and tools to assemble product. If correct fasteners and tools are not used, product may fail.
- When using clamp mounted product do not install arm until clamp is securely attached to mounting surface.
- When a monitor is not attached to arm assembly, arm may swing upward and cause harm to you or damage to product.

Table of Contents

Parts List.....	3
Installation to Mounting Surface	4
Control Bolt Tension Adjustment.....	6
Arm Height Adjustment.....	7
Installation to Screen.....	7
Cable Management	8

For customer care call (800) 865-2112 or (708) 865-8870.

Before you begin, make sure all parts shown are included with your product.

Parts List		LCT-A1B4C	LCT-A1B4H
Description		Qty	Qty
A	pipe assembly	1	1
B	arm assembly	2	2
C	M4 x 10 mm screws	8	8
D	M4 x 16 mm screws	8	8
E	bar bushing	2	2
F	cable guide	4	4
G	lower pipe cap	1	1
H	upper pipe cap	1	1
J	M4 x 8 mm screws	6	6
K	4 mm allen wrench	1	1
L	2.5 mm allen wrench	1	1
M	bolt	-	1
N	spring washer	-	1
O	flat washer	-	1
P	bottom washer	-	1
Q	8 mm wrench	-	1

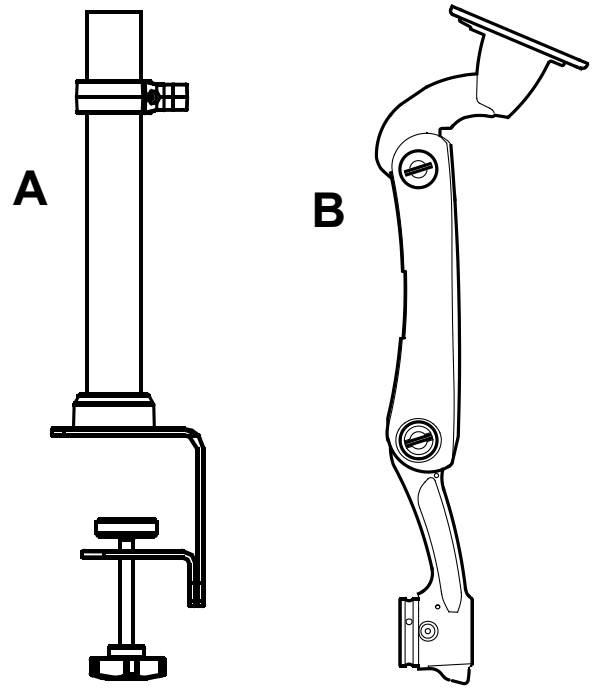

Parts may appear slightly different than illustrated.

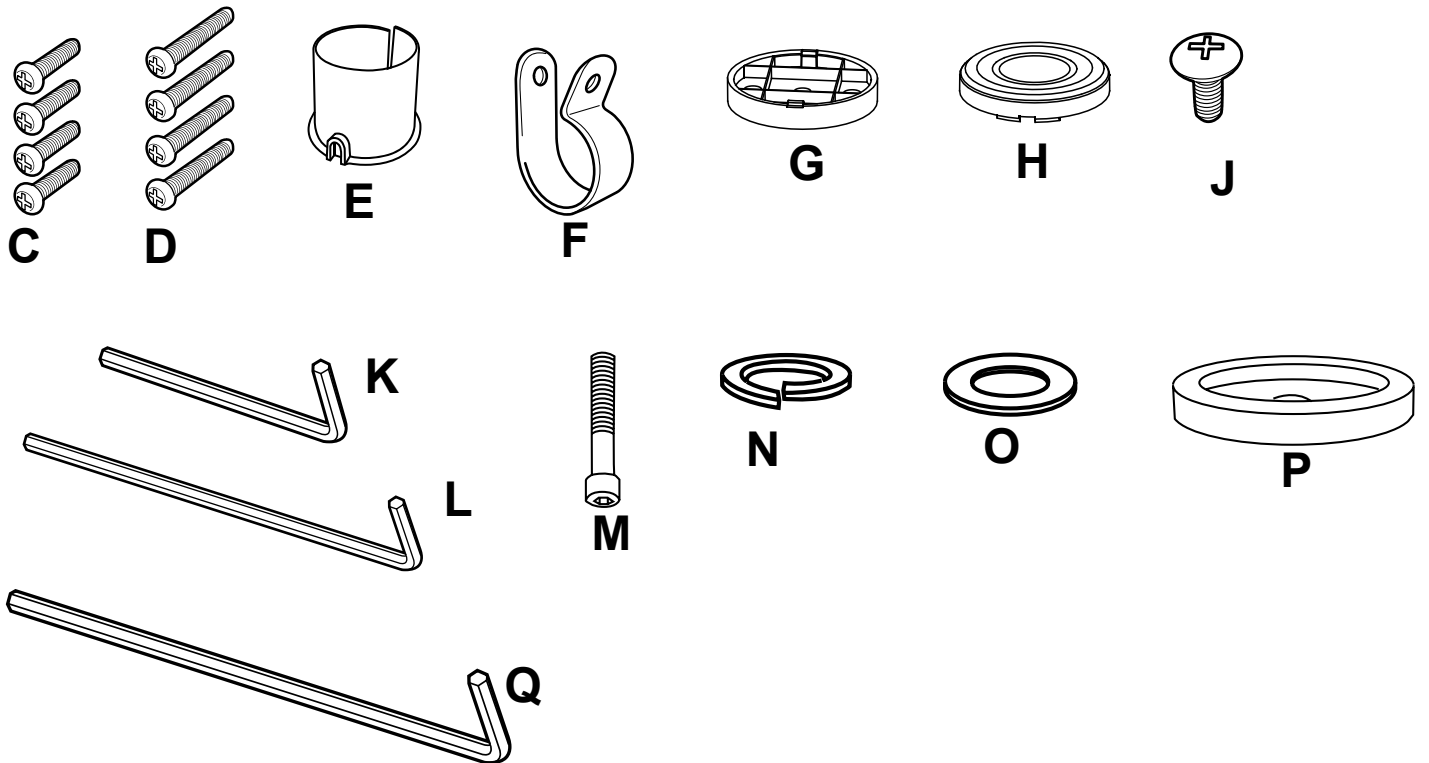

Clamp Installation Method

- 1** Pipe assembly (A) can be mounted to mounting surface with a thickness of 1/3" - 3.5" (8.5 - 89 mm). Insert the clamp onto mounting surface as shown below.

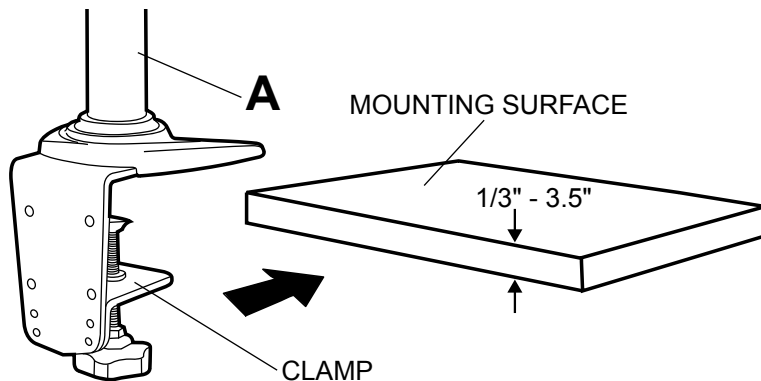

- 1-1** Turn handle to tighten pipe assembly (A) to mounting surface until firmly attached.

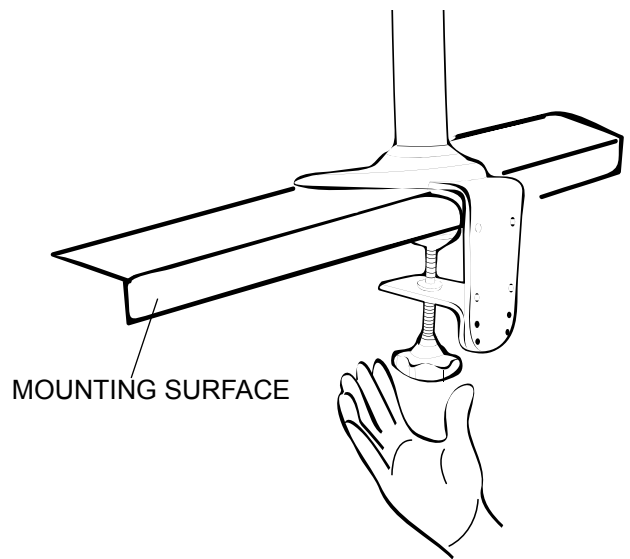

Hole Installation Method

- 2** Drill .5" (13 mm) hole into mounting surface. Place pipe assembly (A) onto mounting surface and secure using one bolt (M), one spring washer (N), one flat washer (O), and one bottom washer (P) as shown in figure 2.1. Tighten bolt (M) using 8 mm wrench (Q) as shown in figure 2.2.

NOTE: Be sure fasteners and washers are assembled in correct order as shown in detail 1.

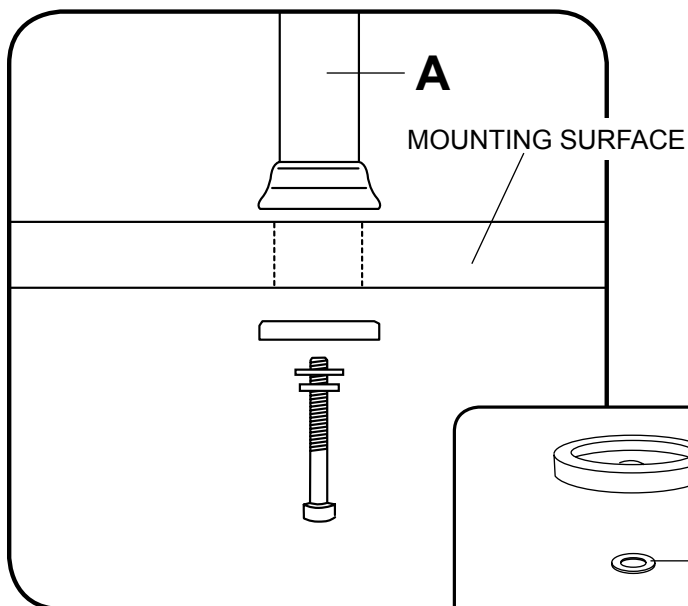
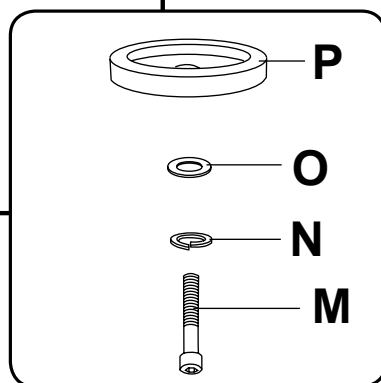

fig. 2.1



DETAIL 1

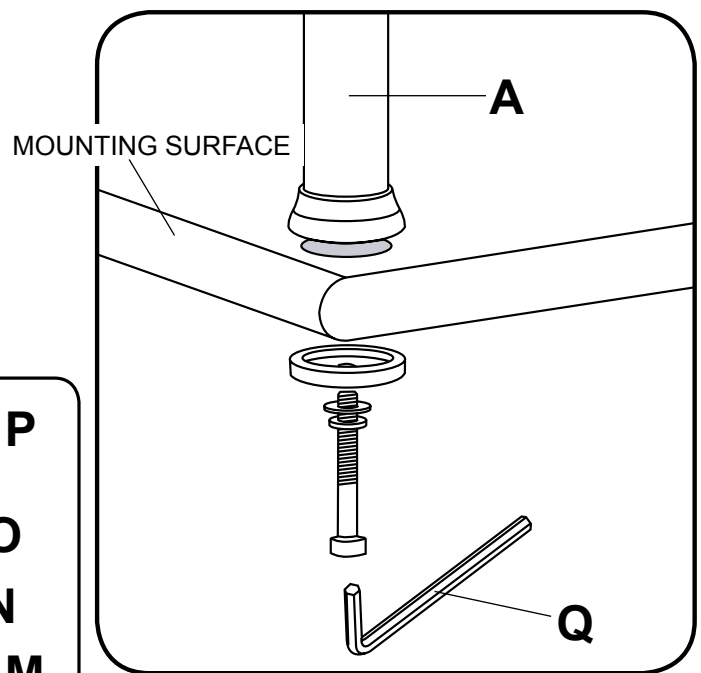
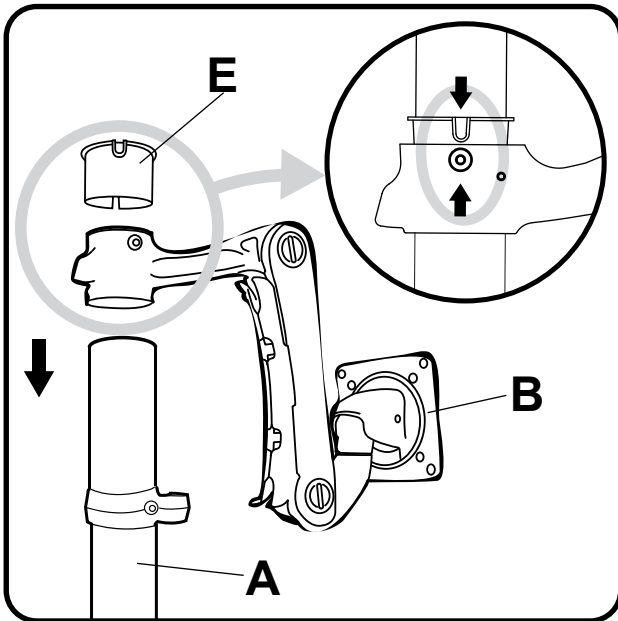
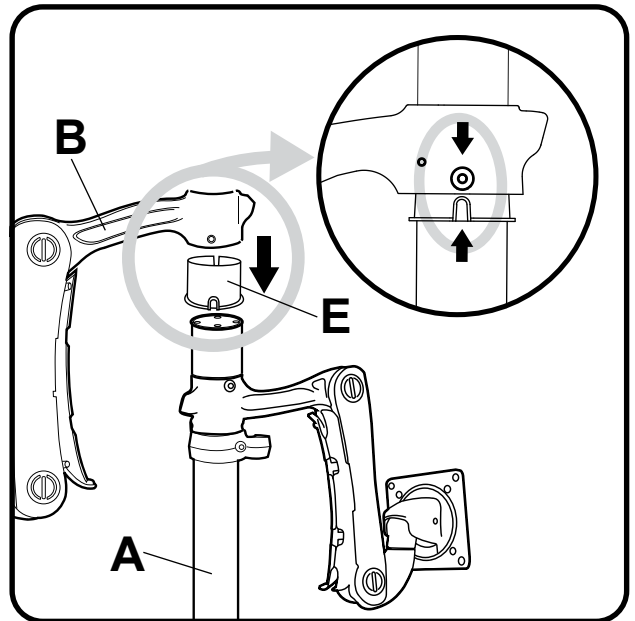

fig. 2.2

- 3** Place arm assembly #1 (B) over pipe then insert bar bushing (E) over pipe into arm assembly (A) and align with set screw on pipe assembly (A).



- 3-1** Place bar bushing (E) over pipe and align with set screw on pipe assembly (A) and then place arm assembly #2 (B) over pipe assembly and bar bushing (E).



- 3-2** **NOTE:** When installing both arms to pipe assembly, be aware of curve direction of arms. Arm assembly #1 should be curved upwards and arm assembly #2 should be curved downwards so that both monitors can be parallel.

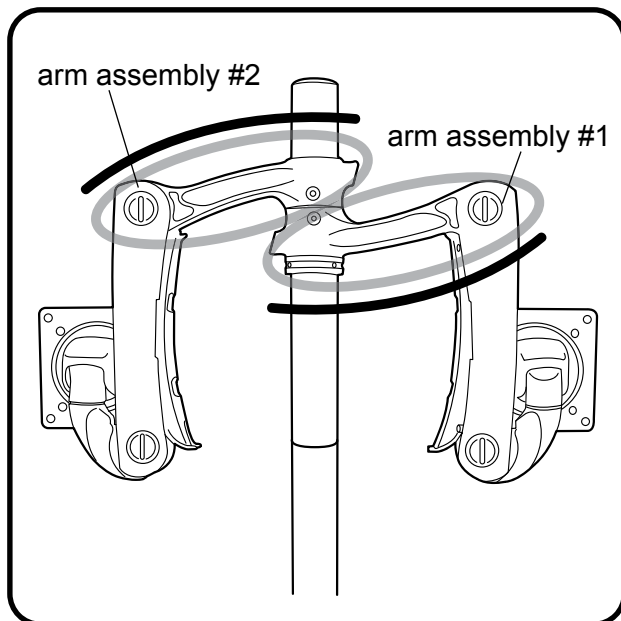

- 4** Attach lower pipe cap (G) to top of pipe assembly (A) using two M4 x 8 mm screws (J).

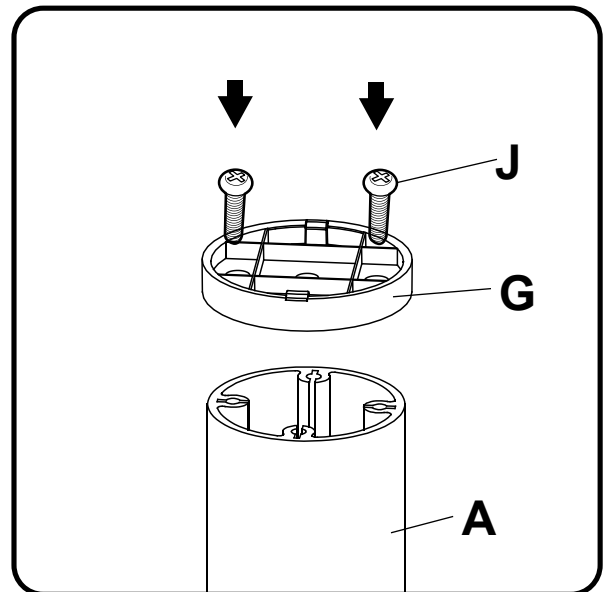

- 5** Attach upper pipe cap (H) to lower pipe cap as shown below until click sound is heard.

- 6** Adjust arm to desired height and tighten set screw on both arms using 2.5 mm allen wrench (L).

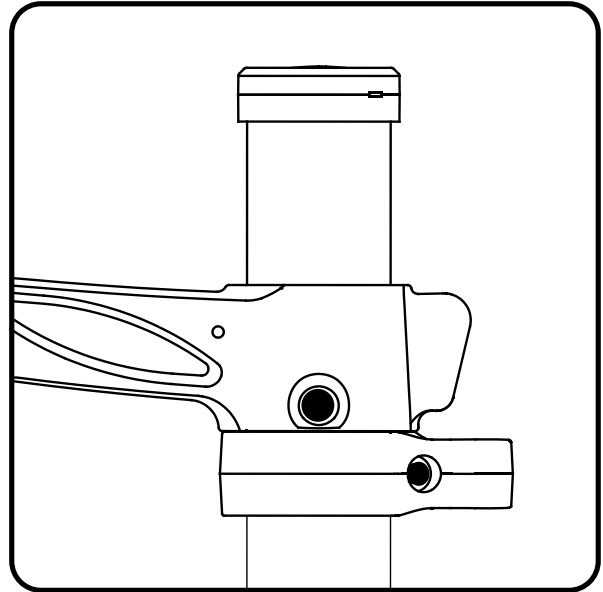
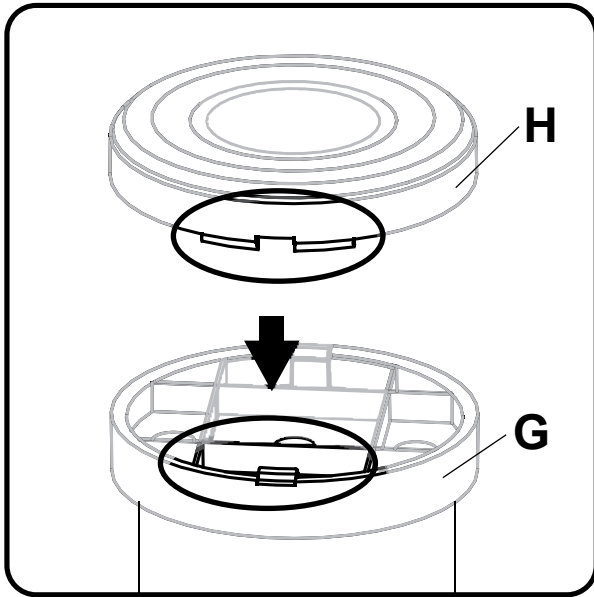

Control Bolt Tension Adjustment

- 7** **NOTE:** This product is factory set for a 19" (483 mm) monitor. When changing the size of the monitor, adjust the control bolt with 4 mm allen wrench (K) as shown in figure 7.1.

Adjust control bolt at top of arm assembly (B) with 4 mm allen wrench (K) as shown in figure 7.2.

Bend lower arm to access control bolt. Adjust control bolt with 4 mm allen wrench (K) as shown in figure 7.3.

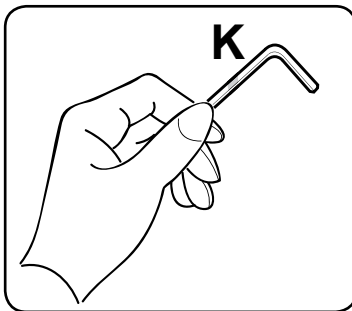

fig. 7.1

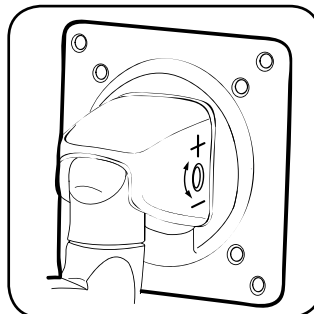

fig. 7.2

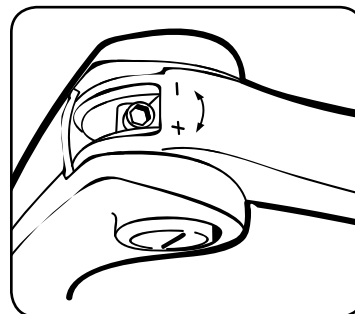
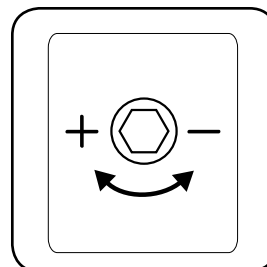

fig. 7.3

CAUTION

- Be careful not to pinch fingers when adjusting arms of arm assembly (A).



NOTES:

- Turn control bolt clockwise (+) to adjust for weight greater than 8.8 lbs (4 kg).
- Turn control bolt counter-clockwise (-) to adjust for weight less than 8.8 lbs (4 kg).

Height Adjustment of Arm

- 8** Loosen pipe assembly set screw using 4 mm allen wrench (**K**) then loosen arm assembly set screw using 2.5 mm allen wrench as shown in detail 2. Adjust monitor to desired height as shown in figure 8.1, then retighten all fasteners.

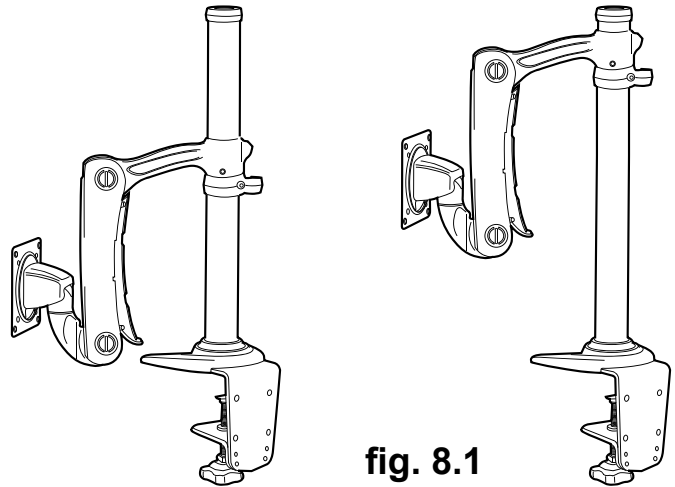
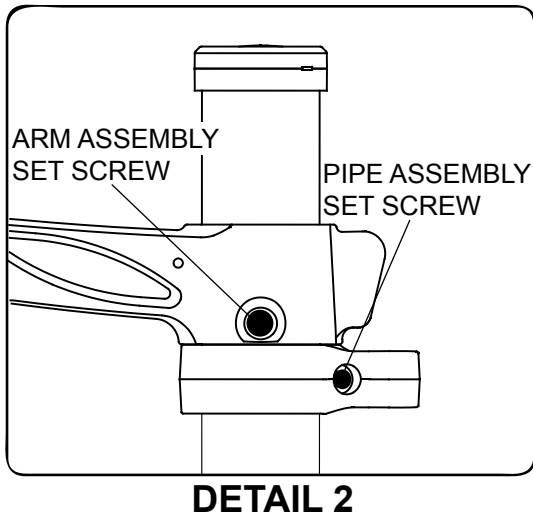

Installation to Screen

- 9** Attach front of arm assembly (**B**) to back of screen with four screws (**C or D**) as shown in detail 3 using VESA 75 or VESA 100 mounting pattern as shown in figure 9.1.

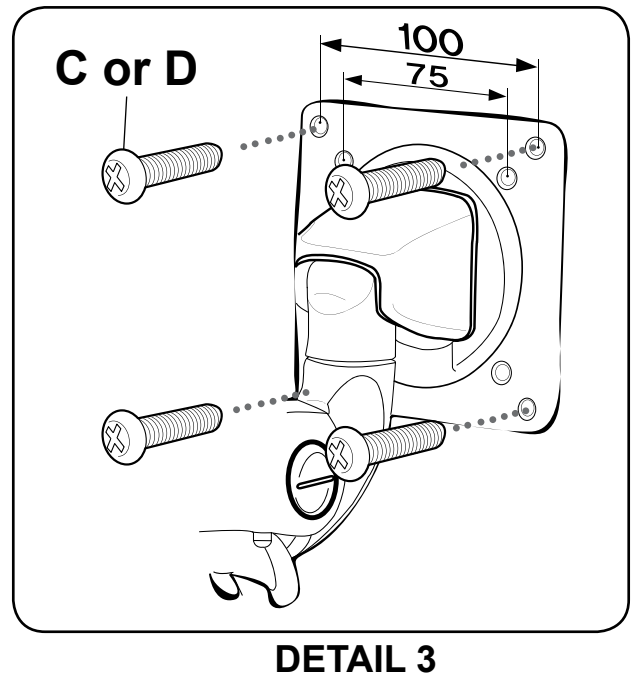
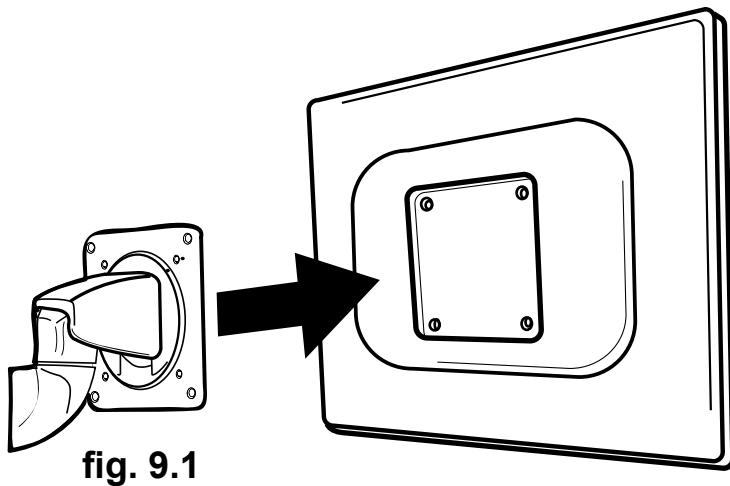

Cable Management

- 10** Loop cords through cable guide (F) and attach to arm using one M4 x 8 mm screw (J) as shown below.

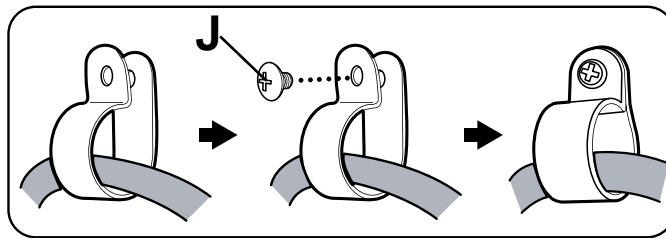
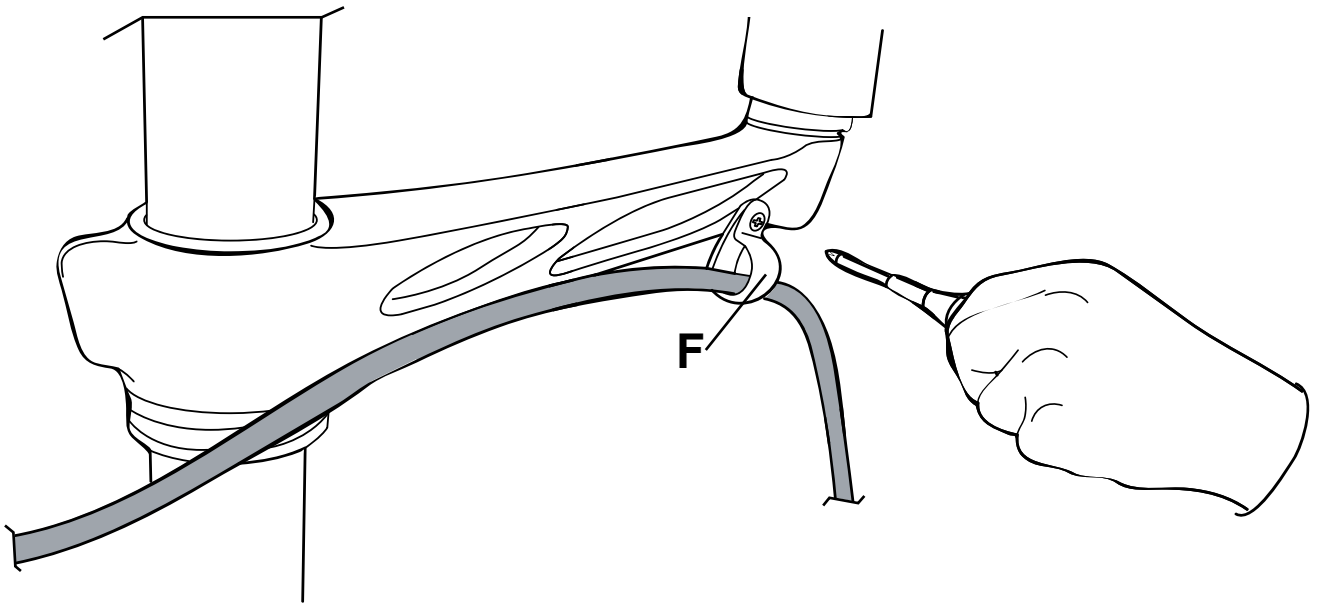

- 11** Cords may also route through arm assembly.
Open gap to press fit cables as shown in detail 4.

