

# peerless®

## Installation and Assembly: In-wall Mount for 32" to 71" Flat Panel Screens

Model#	Screen size range
IM760P, IM760P-S	32" to 71" (81 to 180 cm)
IM760PU, IM760PU-S	32" to 60" (81 to 152 cm)

IM760P  
IM760P-S

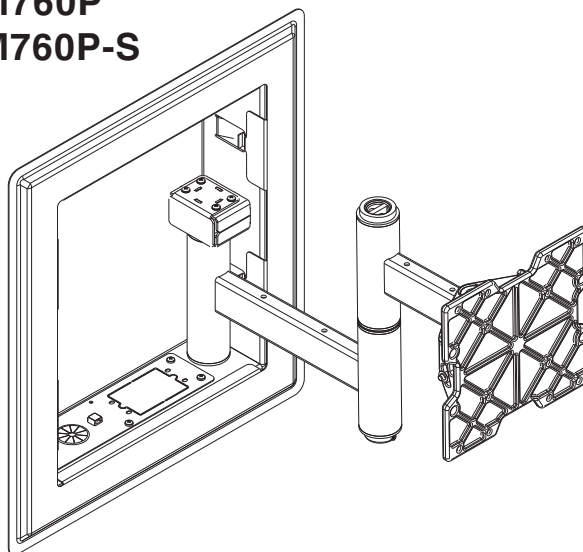

IM760PU  
IM760PU-S

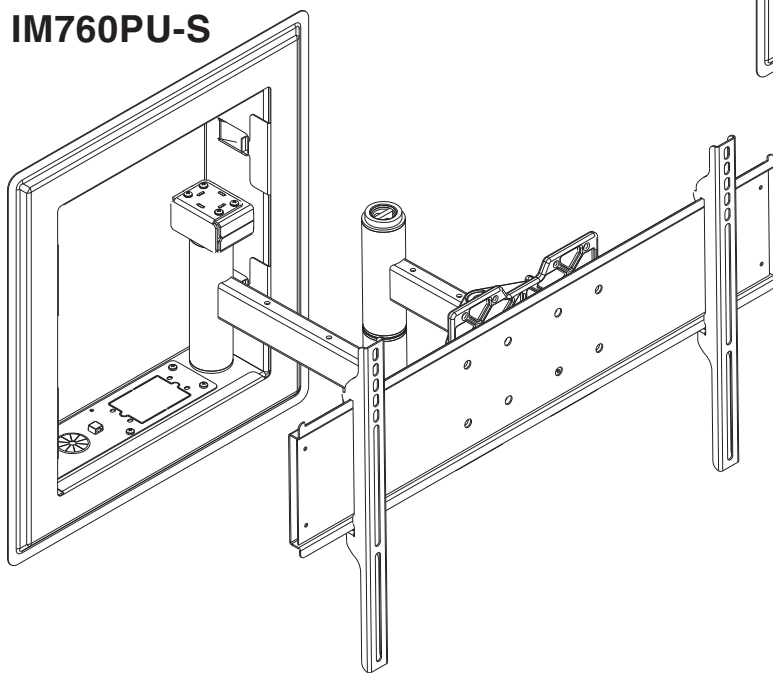

This product is intended for use with UL Listed products and must be installed by a qualified professional installer.

**Maximum UL Load Capacity:**  
200 lb (90.7 kg)

**Note:** Read entire instruction sheet before you start installation and assembly.

## ⚠ WARNING

- Do not begin to install your Peerless product until you have read and understood the instructions and warnings contained in this Installation Sheet. If you have any questions regarding any of the instructions or warnings, please call Peerless customer care at 1-800-865-2112.
- This product should only be installed by someone of good mechanical aptitude, has experience with basic building construction, and fully understands these instructions.
- Make sure that the supporting surface will safely support the combined load of the equipment and all attached hardware and components.
- Never exceed the Maximum UL Load Capacity.
- If mounting to wood wall studs, make sure that mounting screws are anchored into the center of the studs. Use of an "edge to edge" stud finder is highly recommended.
- Always use an assistant or mechanical lifting equipment to safely lift and position equipment.
- Tighten screws firmly, but do not overtighten. Overtightening can damage the items, greatly reducing their holding power.
- This product was designed and intended to be mounted to the following supporting surfaces checked below with the hardware included in this product as specified in the installation sheet. To mount this product to an alternative supporting surface, contact Peerless customer care at 1 800 865-2112.
- This product was designed to be installed on the following wall construction only;

**WALL CONSTRUCTION**

**ADDITIONAL HARDWARE REQUIRED**

<input checked="" type="checkbox"/> Wood Stud	None
<input type="checkbox"/> Wood Beam	Contact Customer Service
<input type="checkbox"/> Solid Concrete	Contact Customer Service
<input type="checkbox"/> Cinder Block	Contact Customer Service
<input type="checkbox"/> Metal Stud	Contact Customer Service
<input type="checkbox"/> Brick	Contact Customer Service
<input type="checkbox"/> Other or unsure?	Contact Customer Service

### Tools Needed for Assembly

- stud finder ("edge to edge" stud finder is recommended)
- phillips screwdriver
- drill
- 5/32" bit for wood stud wall
- level

### Table of Contents

---

Parts List .....	3, 4
Installation to Wood Stud Wall .....	5, 6
Installing Arm to In-wall Box .....	7
Disassemble Mounting Plate .....	8
Attaching Mounting Plate to Screen with VESA Mounting Pattern .....	8
Attaching Adapter Plate to Screen .....	9, 10
Installing and Removing Flat Panel Screen .....	11
Adjusting Flat Panel Screen .....	11
Cable Management .....	12

Before you begin, make sure all parts shown are included with your product.

<b>Parts List</b>			<b>IM760P</b>	<b>IM760P-S</b>	<b>IM760PU</b>	<b>IM760PU-S</b>
<b>Description</b>	<b>Qty.</b>	<b>Part #</b>	<b>Part #</b>	<b>Part #</b>	<b>Part #</b>	<b>Part #</b>
<b>A</b> arm assembly	1	095-P1529	095-C4529	095-P1529	095-C4529	095-C4529
<b>B</b> in-wall box	1	095-P1534	095-C4535	095-P1534	095-C4535	095-C4535
<b>C</b> arm axle	1	095-P1519	095-C4519	095-P1519	095-C4519	095-C4519
<b>D</b> outer trim	1	095-P1517	095-C4517	095-P1517	095-C4517	095-C4517
<b>E</b> #14 x 2.5" wood screw	6	5S1-015-C03	5S1-015-C03	5S1-015-C03	5S1-015-C03	5S1-015-C03
<b>F</b> cable bushing	2	590-1295	590-1295	590-1295	590-1295	590-1295
<b>G</b> cable tie	8	590-1168	590-1168	590-1168	590-1168	590-1168
<b>H</b> plastic finishing cap	2	590-1123	590-1123	590-1123	590-1123	590-1123
<b>J</b> cable management clips	8	590-1166	590-1166	590-1166	590-1166	590-1166
<b>K</b> 4 mm allen wrench	1	560-0072	560-0072	560-0072	560-0072	560-0072
<b>L</b> M5 x 12 mm phillips screw	4	520-1027	520-1027	520-1027	520-2008	520-2008
<b>M</b> M4 x 20 mm phillips screw	4	504-9020	504-2014	N/A	N/A	N/A
<b>N</b> M4 x 30 mm phillips screw	4	520-1133	520-1133	N/A	N/A	N/A
<b>O</b> M6 x 20 mm phillips screw	4	520-9402	520-9402	N/A	N/A	N/A
<b>P</b> M6 x 30 mm phillips screw	4	510-9109	510-9109	N/A	N/A	N/A
<b>Q</b> M6 x 40 mm phillips screw	4	520-1584	520-1207	N/A	N/A	N/A
<b>R</b> retaining spacer	4	590-5005	590-5005	N/A	N/A	N/A
<b>T</b> universal adapter plate	1	N/A	N/A	201-P1110	201-C4110	201-C4110
<b>U</b> deep adapter bracket	2	N/A	N/A	200-P1750	200-C4750	200-C4750
<b>V</b> shallow adapter bracket	2	N/A	N/A	200-P1754	200-C4754	200-C4754
<b>W</b> M5 x 10 mm phillips screw	4	N/A	N/A	520-9250	520-9250	520-9250
<b>X</b> M10 x 17 mm serrated washer head socket screw	4	N/A	N/A	520-1105	520-7105	520-7105
<b>Y</b> 6 mm allen wrench	1	N/A	N/A	560-9716	560-9716	560-9716
<b>Z</b> adapter bracket fastener pack	1	N/A	N/A	200-8405-2	200-8405-2	200-8405-2

Parts may appear slightly different than illustrated.

## Adapter Bracket Fastener Pack (Z)

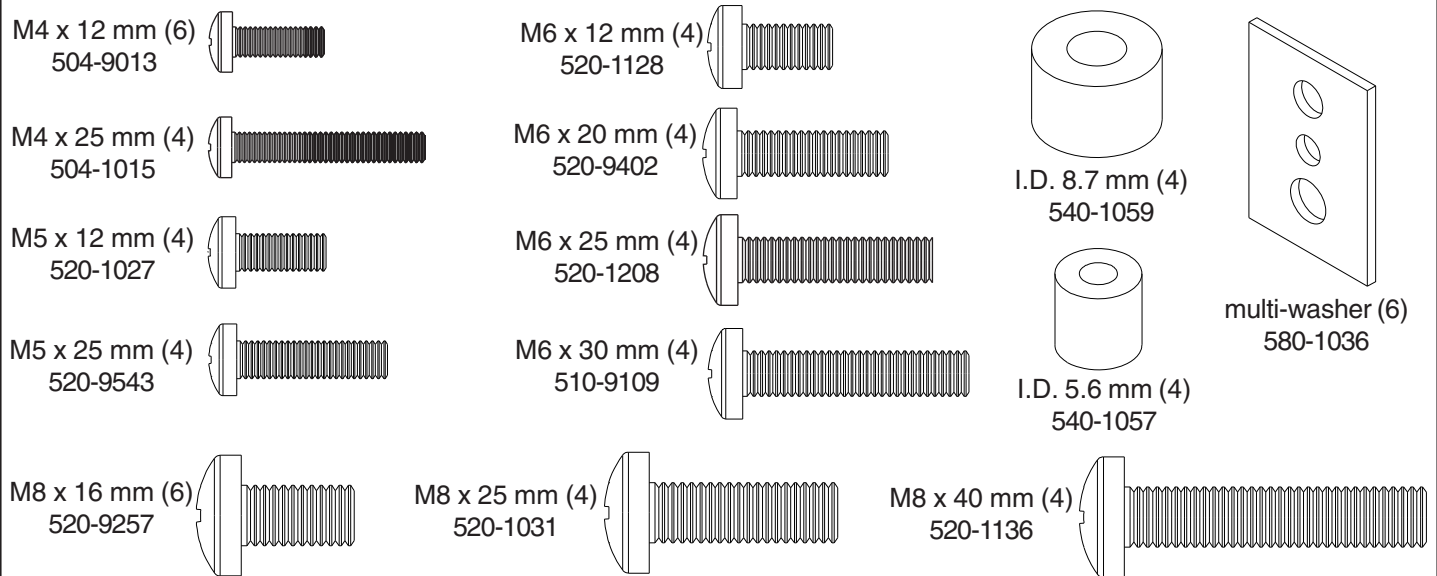

# Part List Continued

Parts may appear slightly different than illustrated.

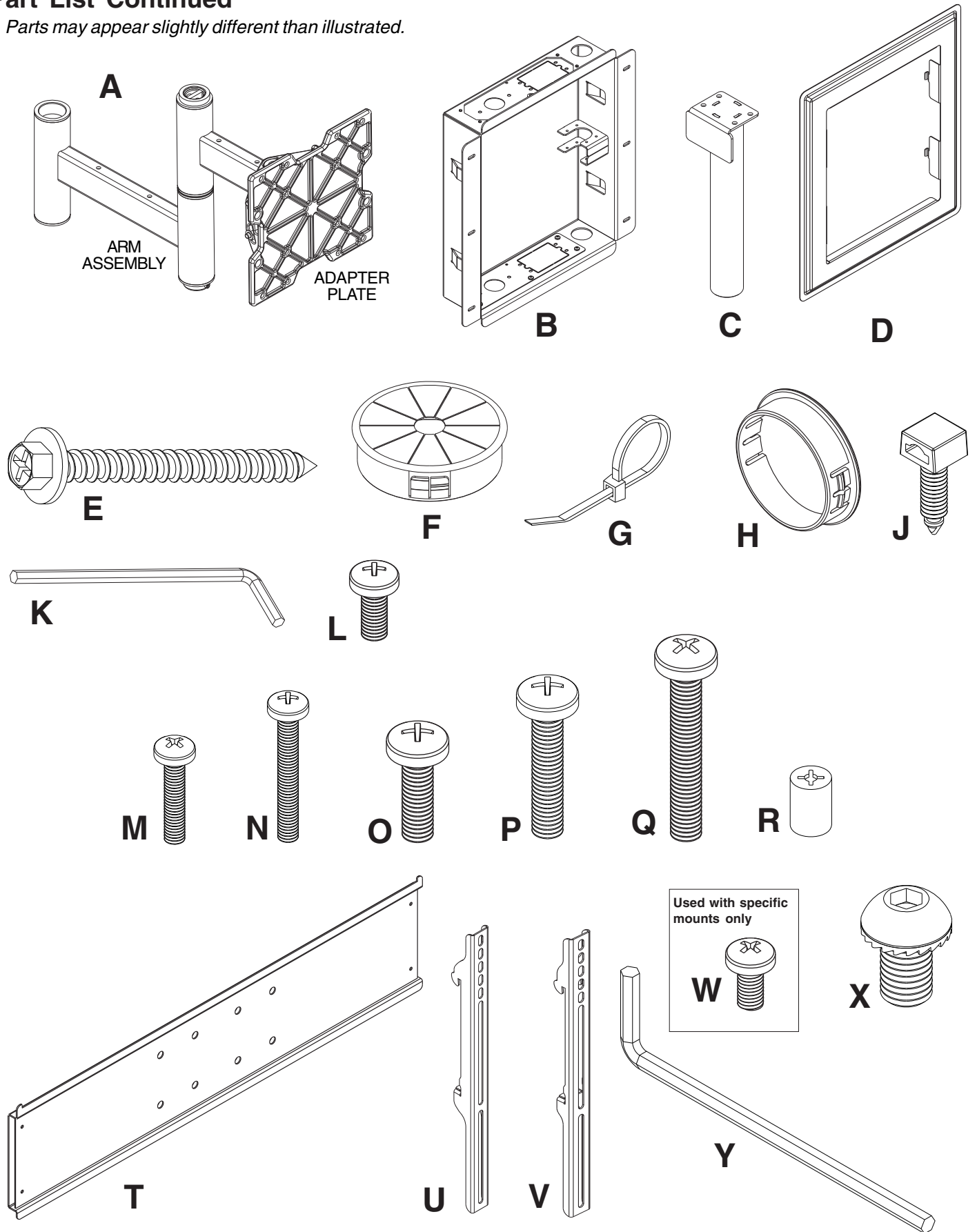

# Installation to Wood Stud Wall

- 1 In-wall box (B) can be installed between two studs 16" off center. Use a stud finder to locate the edges of the stud. Use of an edge-to-edge stud finder is highly recommended. Based on its edges, draw vertical lines down the inside edges of stud's. Mark desired center of screen between studs. Draw a horizontal line above desired center of screen as indicated in figure 1.1 or 1.2. Draw a second horizontal line 16-5/8" (422 mm) below this line to outline wall opening between inside edges of studs. Remove drywall inside cut outline.

## Screen center with models IM760 and IM760P-S:

Center of adapter plate will be located 6" (152 mm) below the top cut line.

**Note:** Center of adapter plate may not represent screen center. Placement of in-wall box will depend on the screen center and location of screen mounting holes in relation to adapter plate.

**Note:** Depending on right or left side mount orientation shown in figure 1.3 in step 1-1, screen center will be 6.39" (162 mm) from the inside edge of stud.

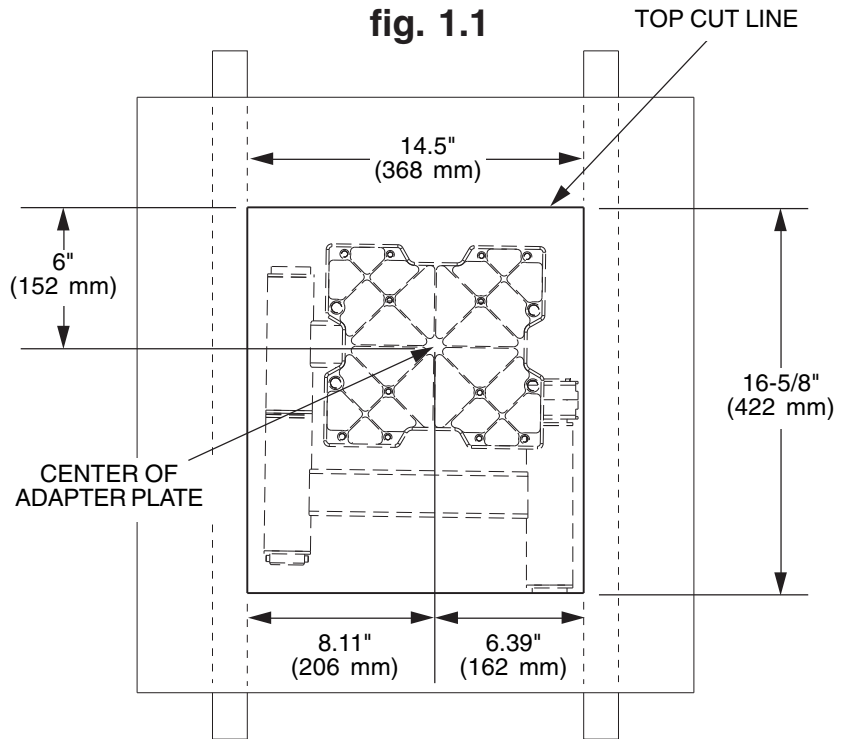

## Screen center with models IM760PU and IM760PU-S:

Center of screen will be located 7-7/8" (200 mm) below the top cut line.

**Note:** Depending on mount orientation shown in figure 1.3 in step 1-1, screen center will be 6.39" (162 mm) from the inside edge of stud.

**Note:** Depending on right or left side mount orientation shown in figure 1.3 in step 1-1, screen center will be 6.39" (162 mm) from the inside edge of stud.

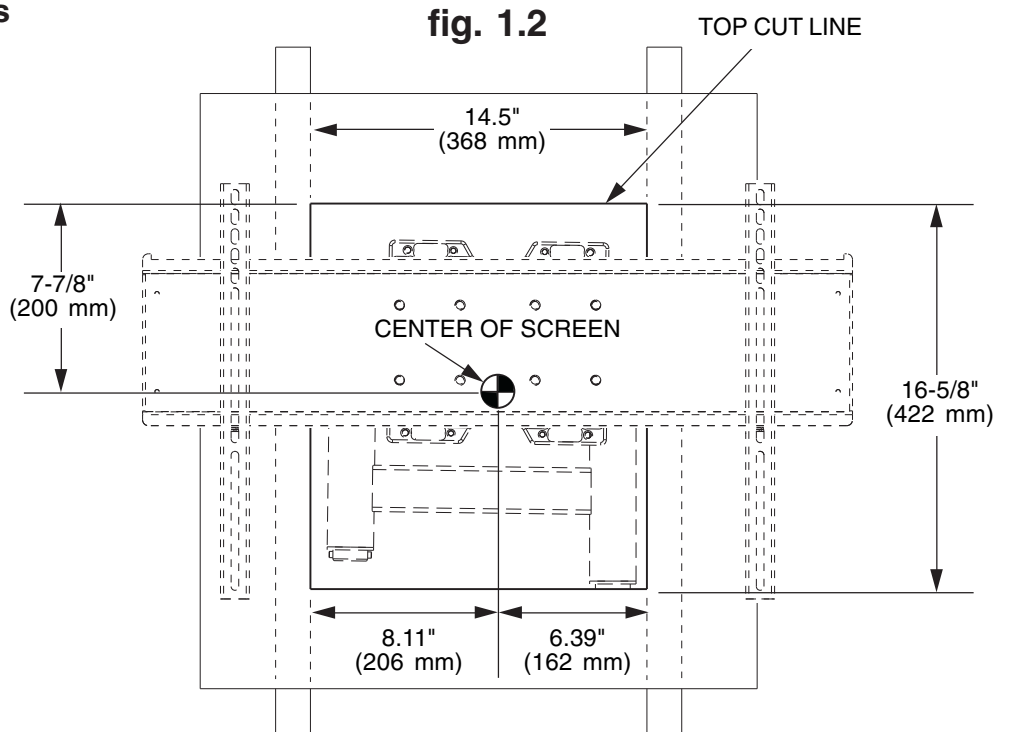

## Installation to Wood Stud Wall (continued)

### ⚠ WARNING

- Installer must verify that the supporting surface will safely support the combined load of the equipment and all attached hardware and components.
- Tighten wood screws so that wall plate is firmly attached, but do not overtighten. Overtightening can damage the screws, greatly reducing their holding power.
- Never tighten in excess of 80 in. • lb (9 N.M.).
- Make sure that mounting screws are anchored into the center of the stud. The use of an "edge to edge" stud finder is highly recommended.
- Hardware provided is for attachment of mount through standard thickness drywall or plaster into wood studs. Installers are responsible to provide hardware for other types of mounting situations.

- 1-1** In-wall box can be flipped for left or right side mount orientation as shown in figure 1.3. Insert in-wall box (**B**) into cut-out. Level in-wall box, and mark the center of the six mounting holes. Drill six 5/32" (4 mm) dia. holes 2-1/2" (65 mm) deep. Make sure in-wall box is level, secure it using six #14 x 2-1/2" wood screws (**E**) as shown in figure 1.4.

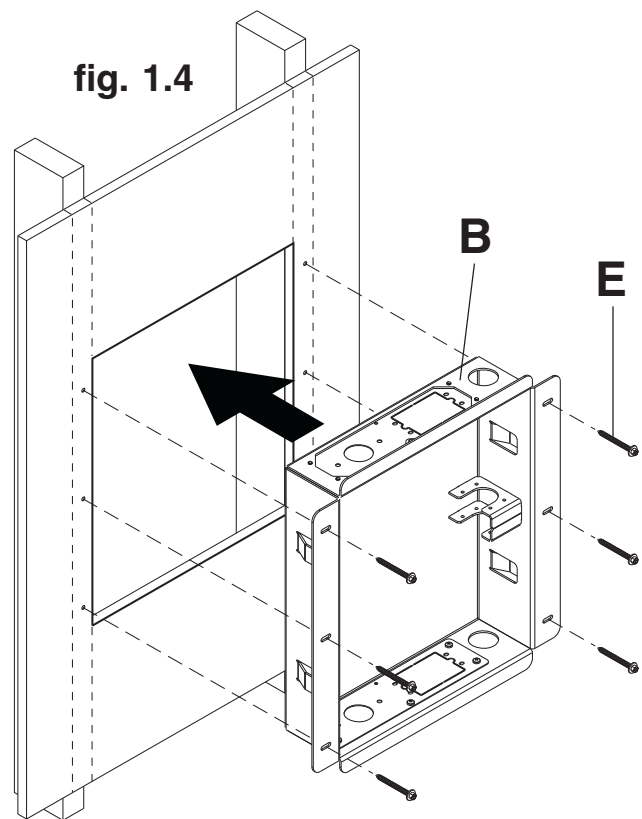
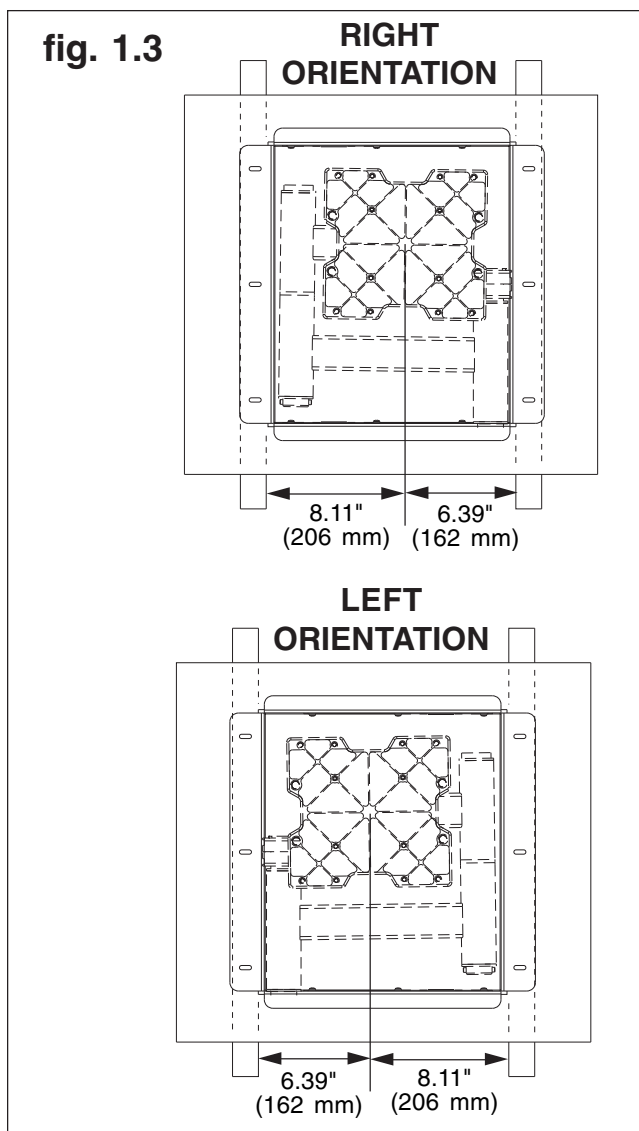

## Installing Arm to In-wall Box

- 2** Insert arm axle (C) through arm assembly (A) as shown in figure 2.1.

Position arm axle (C) and arm assembly (A) into axle support bracket of in-wall box (B) then seat arm axle through bottom hole of in-wall box as shown in figure 2.2.

Secure arm axle to in-wall box using four M5 x 12 mm phillips screws (L) as shown in figure 2.3.

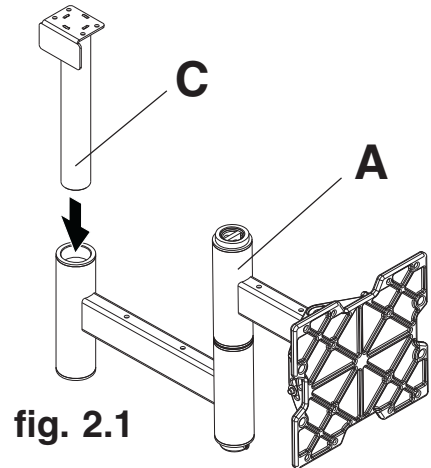

fig. 2.1

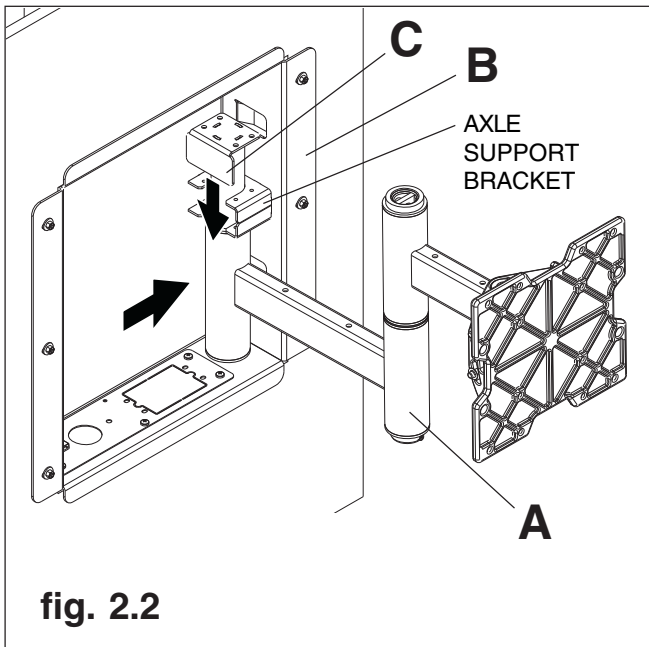

fig. 2.2

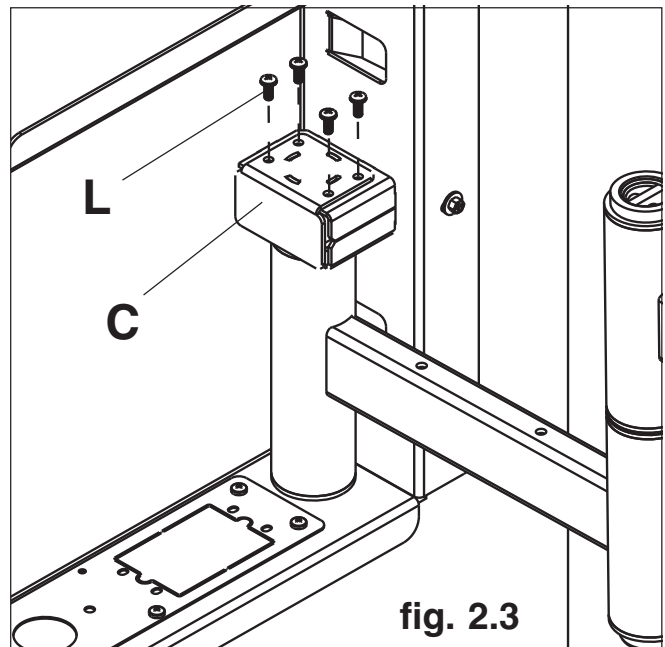

fig. 2.3

## Installing Outer Trim

- 3** Insert tabs of outer trim (D) into notches of in-wall box (B) as shown in figure 3.1.

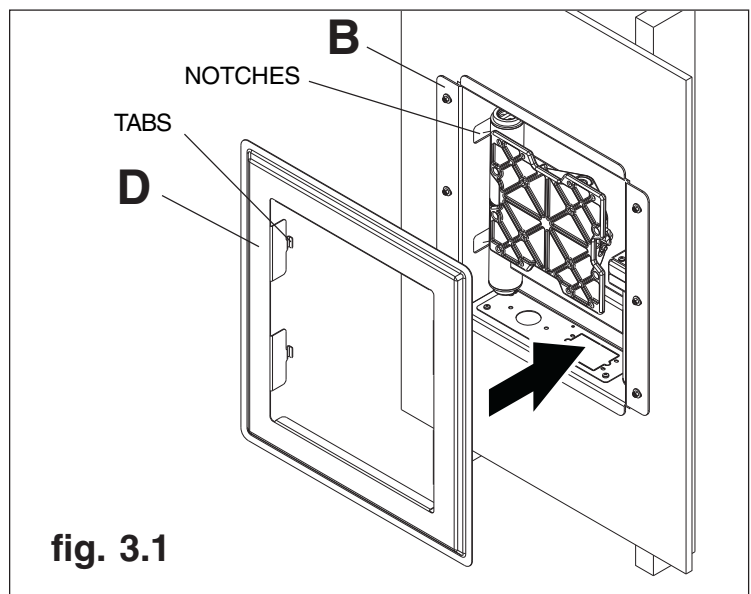
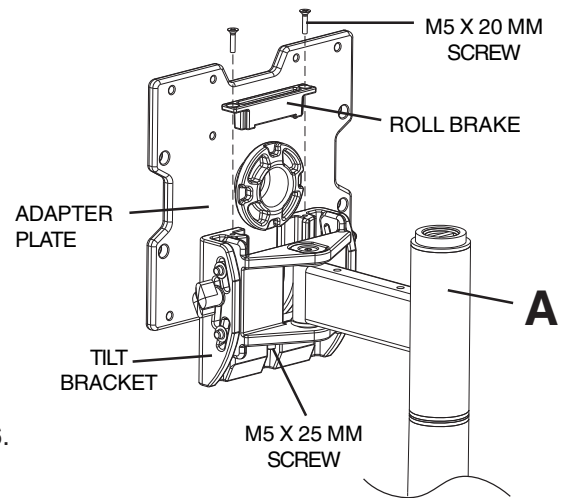

fig. 3.1

## Disassemble Adapter Plate

- 4 Remove two M5 x 20 mm screws from the rollbrake. Lift adapter plate out from tilt bracket as shown.

**NOTE:** M5 X 25 mm screw may need to be loosened a few turns to allow adapter plate to be removed using 4 mm allen wrench (K).



## Attaching Adapter Plate to Screen with VESA® Mounting Pattern

**Note:** For installing screen using universal adapter plate, skip to step 6.

- 5 Identify VESA mounting pattern on back of your screen and choose hole pattern on adapter plate and required fasteners as shown in figure 5.2.

Secure adapter plate to back of screen as shown in figure 5.1 using fasteners indicated in figure 5.2.

**NOTE:** If hole pattern is in a pocket and requires M4 screws, attach adapter plate to back of screen using four M4 x 30 mm screws (N) and four retaining spacers (R) as indicated in figure 5.1.

**NOTE:** Spacers may not be used, depending upon the type of screen.

Skip to step 7

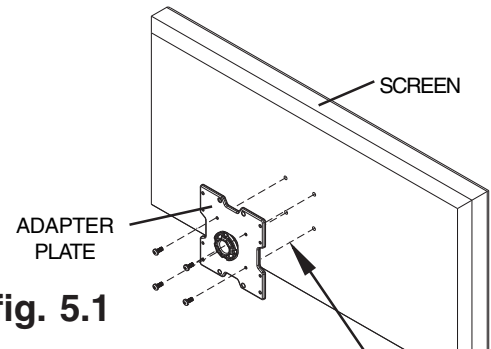

**NOTE:** For screens with a hole pattern in a pocket, spacers go between adapter plate and screen when using M4 x 30 mm screws.

### ⚠ WARNING

- If screws don't get three complete turns in the screen inserts or if screws bottom out and adapter plate is still not tightly secured, damage may occur to screen or product may fail.

## Mounting Patterns

### VESA® 100 x 100

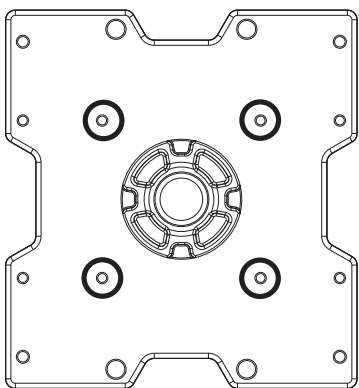

M4 x 20 mm screws (M) or M4 x 30 mm screws (N) with spacer (R)

### VESA® 200 x 100

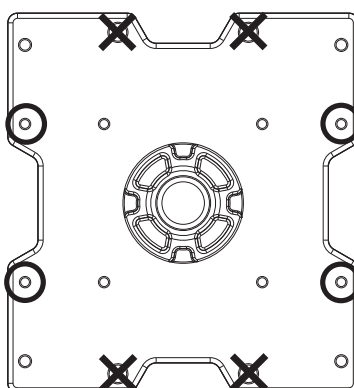

M4 x 20 mm screws (M) or M4 x 30 mm screws (N) with spacer (R)

### VESA® 200 x 200

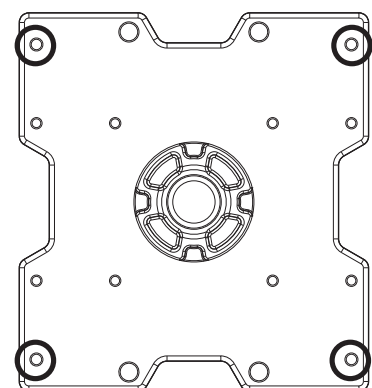

M6 x 20 mm (O), M6 x 30 mm (P) or M6 x 40 mm screws (Q)

fig. 5.2



## Installing Universal Adapter Plate to Screen

- 6** Using the hole pattern shown in detail 1, attach the adapter plate to universal adapter plate (T) with four M10 x 17 mm screws (X) as shown. Tighten screws using 6 mm allen wrench (Y).

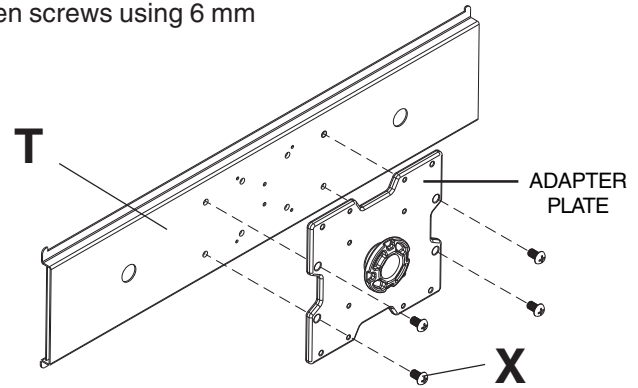
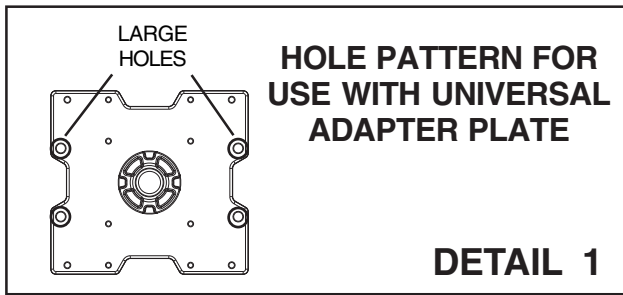

### ⚠ WARNING

- Tighten screws so screen brackets are firmly attached to screen. Do not tighten with excessive force. Overtightening can cause stress damage to screws, greatly reducing their holding power and possibly causing screw heads to become detached. Tighten to 40 in. • lb (4.5 N.M.) maximum torque.
- If screws don't get three complete turns in the screen inserts or if screws bottom out and bracket is still not tightly secured, damage may occur to screen or product may fail.

- 6-1** Visit our website at [www.peerlessmounts.com/2](http://www.peerlessmounts.com/2) to locate your screen compatibility chart to determine the proper fasteners to use.

To prevent scratching the screen, set a cloth on a flat, level surface that will support the weight of the screen. Place screen face side down. If screen has knobs on the back, remove them to allow the adapter brackets to be attached. Place adapter brackets (U or V) on back of screen, align to holes, and center on back of screen as shown in figure 6.1. Attach the adapter brackets to the back of the screen using the appropriate combination of screws, multi-washers, and spacers as shown in figure 6.2 or figure 6.3.

**Note:** Top and bottom holes must always be used.

Verify that all holes are properly aligned, and then tighten screws using a phillips screwdriver.

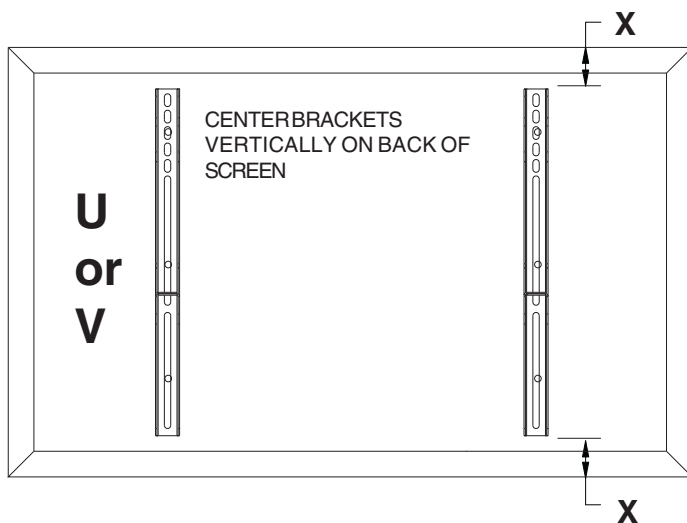
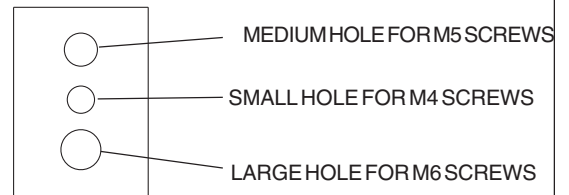

fig 6.1

**Note:** "X" dimensions should be equal.

#### MULTI-WASHER



#### Notes:

- The number of fasteners used will vary, depending upon the type of screen.
- Multi-washers and spacers may not be used, depending upon the type of screen.
- Use the corresponding hole in the multi-washer that matches your screw size.

**NOTE:** For flat back screens proceed to step 6-2. For bump-out or recessed back screen skip to step 6-3

## For Flat Back Screen

**6-2** Begin with the shortest length screw, hand thread through multi-washer and adapter bracket into screen as shown below. Screw must make at least three full turns into the mounting hole and fit snug into place. Do not over tighten. If screw cannot make three full turns into the screen, select a longer length screw from the baffled fastener pack. Repeat for remaining mounting holes, level brackets and tighten screws.

**NOTE:** Spacers may not be used, depending upon the type of screen.

If you have any questions, please call Peerless customer care at **1-800-865-2112** or visit our website at [www.peerlessmounts.com/2](http://www.peerlessmounts.com/2) to locate your screen compatibility chart.

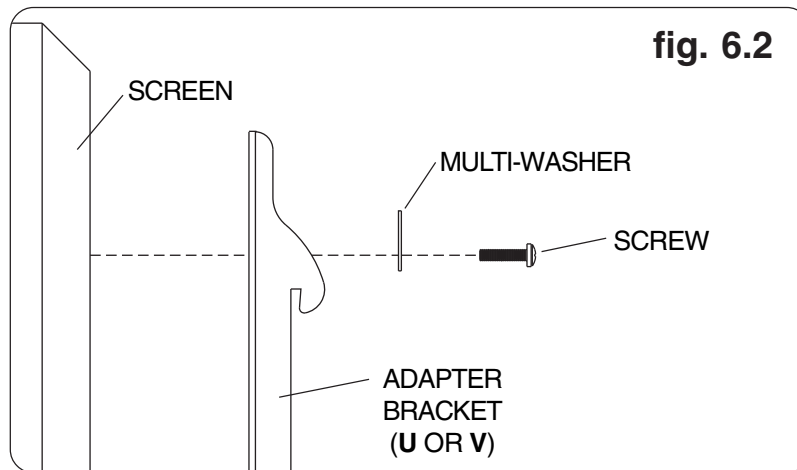

## For Bump-out or Recessed Back Screen

**6-3** Begin with longer length screw, hand thread through multi-washer, adapter bracket and spacer in that order into screen as shown below. Screw must make at least three full turns into the mounting hole and fit snug into place. Do not over tighten. If screw cannot make three full turns into the screen, select a longer length screw from the baffled fastener pack. Repeat for remaining mounting holes, level brackets and tighten screws.

If you have any questions, please call Peerless customer care at **1-800-865-2112** or visit our website at [www.peerlessmounts.com/2](http://www.peerlessmounts.com/2) to locate your screen compatibility chart.

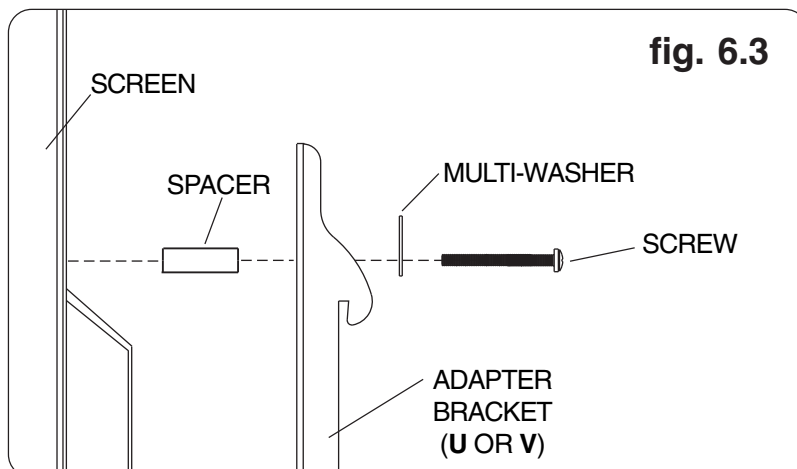

## ⚠ WARNING

- Do not lift more weight than you can handle. Use additional man power or mechanical lifting equipment to safely handle placement of the screen.
- Failure to lock brake pad with two M5 x 20 mm screws and lock tilt bracket with M5 x 25 mm screw can cause screen to come off mount if hit accidentally.

### Installing and Removing Flat Panel Screen

- 7** To attach screen to arm (A), insert the puck of adapter plate into the tilt bracket slot as shown in figure 7.1. Attach brake pad assembly as shown in figure 7.2 so that the brake pad is snug against the puck. Adjust roll position of adapter plate to level screen then lock puck in place by tightening M5 x 25 mm screw on the underside of tilt bracket using 4 mm allen wrench (K). Tighten all (M5 x 20 mm, M5 x 25 mm) screws.

**NOTE:** To remove screen from tilt bracket, remove two M5 x 20 mm screws and brake pad. Lift screen out of tilt bracket.

## CAUTION

- Do not tighten screws with excessive force. Overtightening can cause damage to mount. Tighten M5 x 20 mm screws to 20 in. • lb (2.26 N.M.) maximum torque.

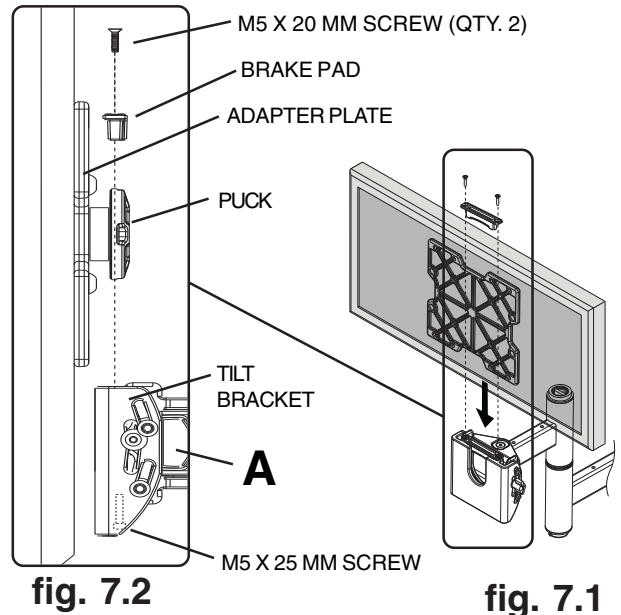

### Adjustment of Flat Panel Screen

- 8 FOR PORTRAIT OR LANDSCAPE SCREEN ORIENTATION:** Remove two M5 x 20 mm screws and brake pad. Lift screen out of tilt bracket. Rotate screen into portrait or landscape position. Insert adapter plate puck into the tilt bracket slot as shown in figure 7.1. Attach brake pad to tilt bracket using two M5 x 20 mm screws as shown in figure 7.2. Tighten all (M5 x 20 mm, M5 x 25 mm) screws.

**TILT Adjustment:** Adjust tension knob on side of mount to desired tension to enable tilt adjustment and balance your screen size and weight. Push or pull from top or bottom of screen to adjust tilt as shown. The tilt can be adjusted to a maximum of 10° forward or 5° backward. Retighten tension knob.

**ROLL Adjustment:** Rotate screen either 5° clockwise or counter-clockwise, level screen then tighten M5 x 25 mm screw using 4 mm allen wrench (K) as shown in bottom view.

## ⚠ CAUTION

- Do not tighten screws with excessive force.
- Be careful not to pinch fingers when opening and closing mount from the wall.

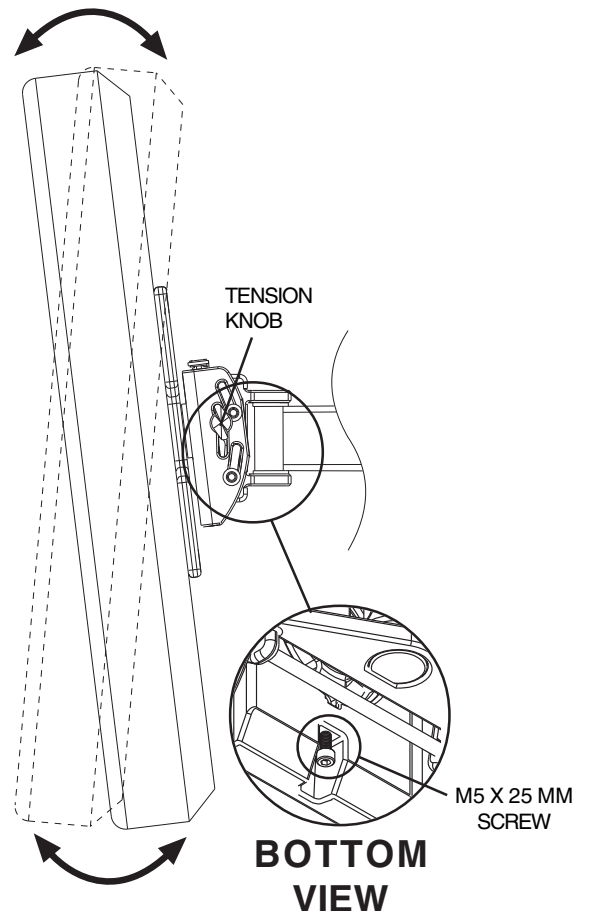

## Cable Management

- 9 For optional installation of electrical gang box, access plates located on the bottom or top of in-wall box can be temporarily removed to install electrical gang box as shown in figure 9.1.

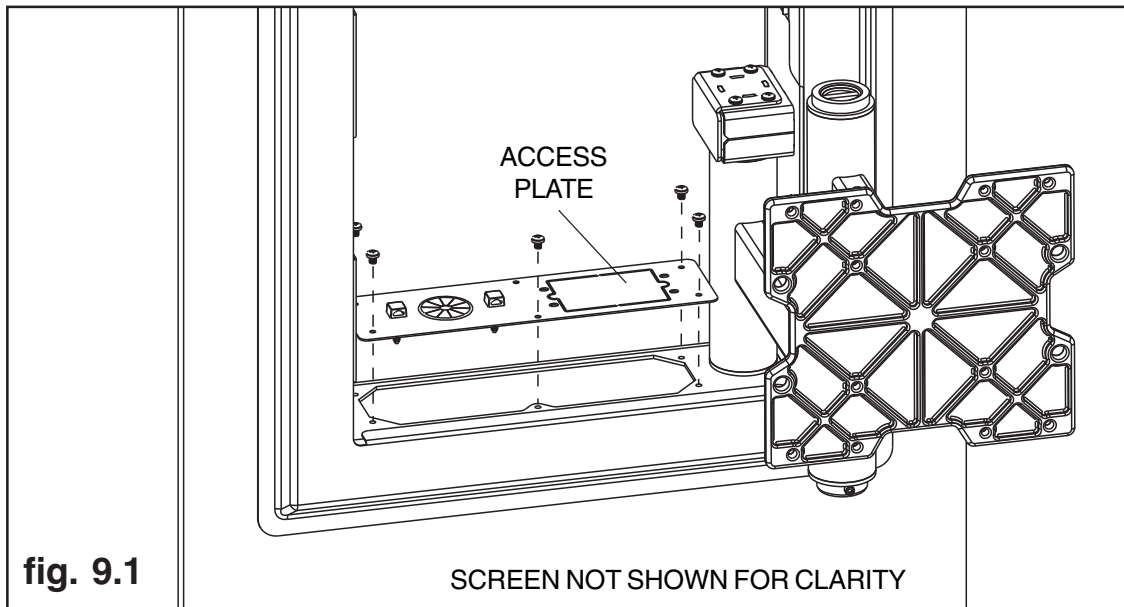

- 9-1 Insert up to eight cable management clips (J) into the desired positions in the arm assembly and in-wall box as shown in figure 9.2 for routing cables.

Insert cable bushing (F) into top or bottom hole of in-wall box for routing cables through in-wall box. Plastic finishing caps (H) can be used in holes where cables are not being routed.

**NOTE:** Make sure cables have enough slack to allow full movement of the arm.

Use cable ties (G) to secure cables to cable management clips as shown in figure 9.3.

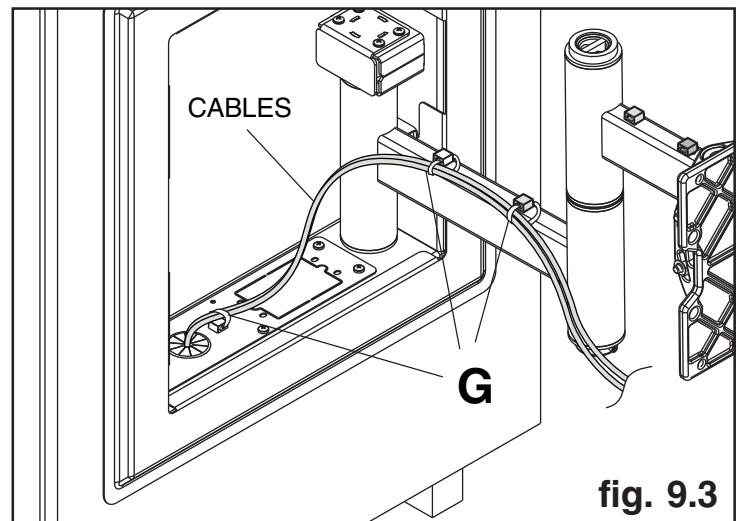
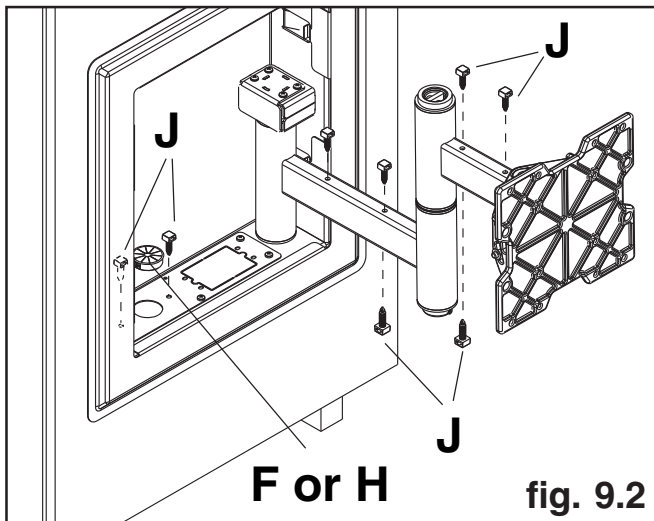

SCREEN NOT SHOWN FOR CLARITY