

TECHNICAL DATA SHEET - Universal 25" to 27" Desktop Swivel Mount

peerless[®]
Solid Solutions - Solid Support™

MODELS: LDS 2527U, LDS 2527U-S

The **Universal 25" to 27" Desktop Swivel Mount** is designed to secure most 25" to 27" TV's to a desktop, countertop, armoire or similar mounting surface.

Features:

- Theft resistant Penta Pin™ Security screws
- Ball bearing race for smooth rotation
- 360° swivel
- Swivel restriction at 0°, 10°, 30°, 60° or 90°
- Mounting hardware included
- Heavy duty steel construction
- Scratch resistant black or silver fused epoxy finish
- Universal tray and swivel base
- Front loading for ease of installation
- Cover plate to conceal Penta Pin™ screws

Dimensions:

All dimensions: in (mm)

Weight:
10.6 lb (4.8 kg)

Shipping weight:
11.4 lb (5.2 kg)

Maximum Load Capacity:
125 lb (57 kg)

Shipping Carton dimensions:
L = 26 in (660 mm)
W = 13 in (330 mm)
H = 1.5 in (38 mm)

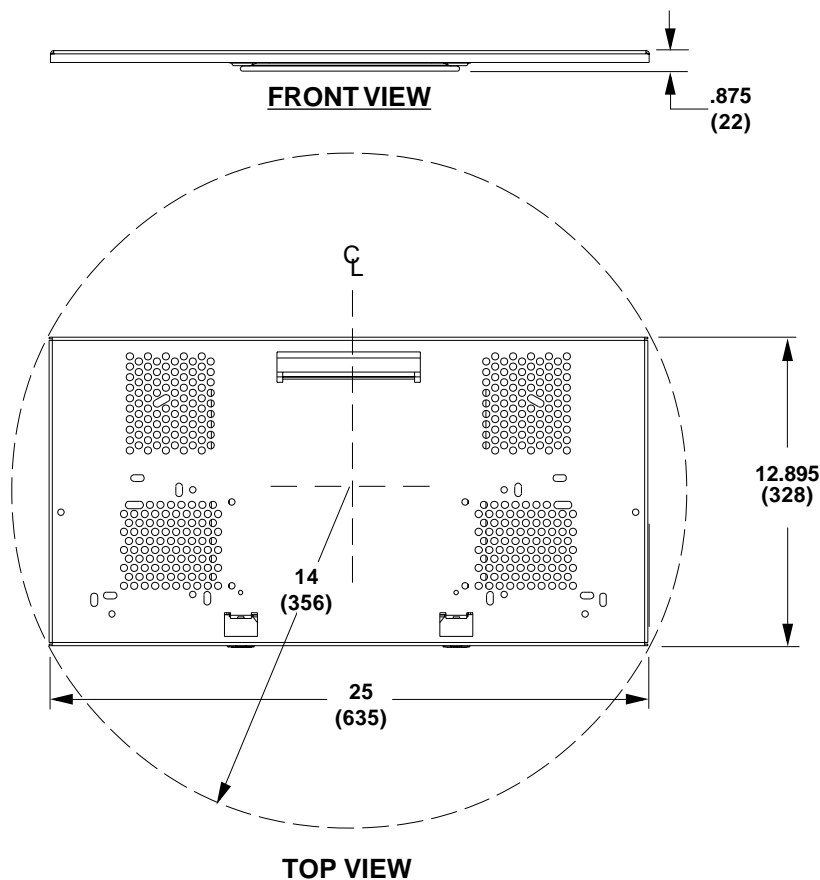

ARCHITECTS SPECIFICATIONS

The Universal 25" to 27" Desktop Mount shall be Peerless models **LDS 2527U** and **LDS 2527U-S** and shall be installed where indicated on the plans. It shall feature theft resistant security screws. It shall feature 0°, 10°, 30°, 60° & 90° swivel restriction. It shall be constructed of cold rolled steel and finished in scratch resistant black or silver fused epoxy. All mounting hardware shall be included. Assembly and installation shall be done according to instructions provided by the manufacturer.

Peerless Industries, Inc.
3215 W. North Ave. Melrose Park, IL 60160
708-865-8870 800-865-2112 Fax 708-865-2941
www.peerlessindustries.com

ISSUED: 11-03-04 SHEET NO: 090-9567-2 12/07/05

©2004 Peerless Industries, Inc. All rights reserved.
Peerless is a registered trademark of Peerless Industries, Inc.
All other brand and product names are trademarks or registered trademarks of their respective owners.