

# TECHNICAL DATA SHEET - Multichannel Speaker Mount

# peerless®

MODEL: MSA-101, MSA-101S

The **MSA-101** mounts a single chassis, multichannel speaker to Peerless mounts. Specifically intended for use with Boston Acoustics model P400 and Polk Audio center channel models. Contact technical support for compatibility with other models.

**IMPORTANT NOTE:** Verify that combined weight of MSA-101, speaker, and screen does not exceed max weight load capacity for wall mount unit.

### Features:

- Allows speaker to extend and swivel with screen when pulled out from the wall
- Mounts to Peerless models FPS-1000, SP850, PLA-50, PLA-60, PLAV-60, PLAV-70, PS-1 and PS-2
- Compatible with Boston Acoustics P400 and Polk Audio center channel speakers
- Height adjustable to bring top of speaker to bottom of screen
- Scratch resistant powder coat finish
- Comes in black or silver
- Max load capacity 25 lb

### Dimensions:

#### Weight:

11.00 lb (5.0 kg)

#### Shipping weight:

12.50 lb (5.7 kg)

#### Maximum Load Capacity:

25.00 lb (11.3 kg)

#### Shipping Carton dimensions:

**L** = 24.12 in (613 mm)

**W** = 24.12 in (613 mm)

**H** = 2.25 in (57 mm)

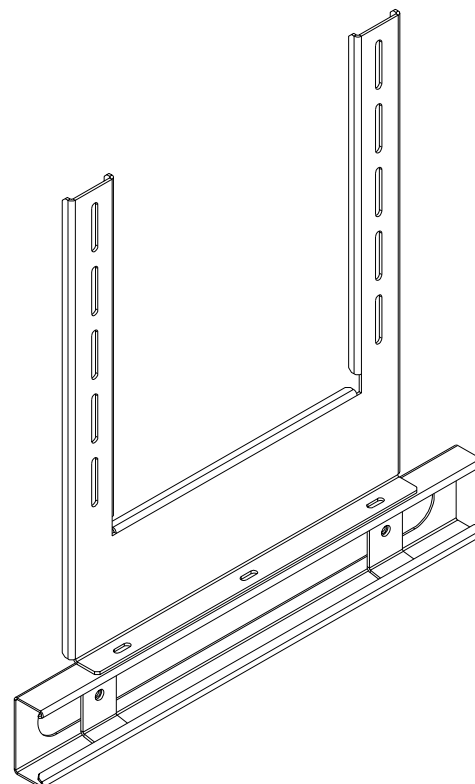

## ARCHITECTS SPECIFICATIONS

The Multichannel Speaker Mount shall be a Peerless model **MSA-101** and shall be located where indicated on the plans. It shall be constructed of heavy gauge cold rolled steel and finished with scratch resistant black or silver fused epoxy finish. Assembly and installation shall be done according to instructions provided by the manufacturer.

### Peerless Industries, Inc.

3215 W. North Ave. Melrose Park, IL 60160  
708-865-8870 800-865-2112 Fax 708-865-2941

[www.peerlessmounts.com](http://www.peerlessmounts.com)

ISSUED: 02-16-06 SHEET NO: 087-9510-3 11-28-06

©2006 Peerless Industries, Inc. All rights reserved.  
Peerless is a registered trademark of Peerless Industries, Inc.

All other brand and product names are trademarks or registered trademarks of their respective owners.

TECHNICAL DATA SHEET

**MODEL: MSA-101, MSA-101S**

All dimensions = inch (mm)

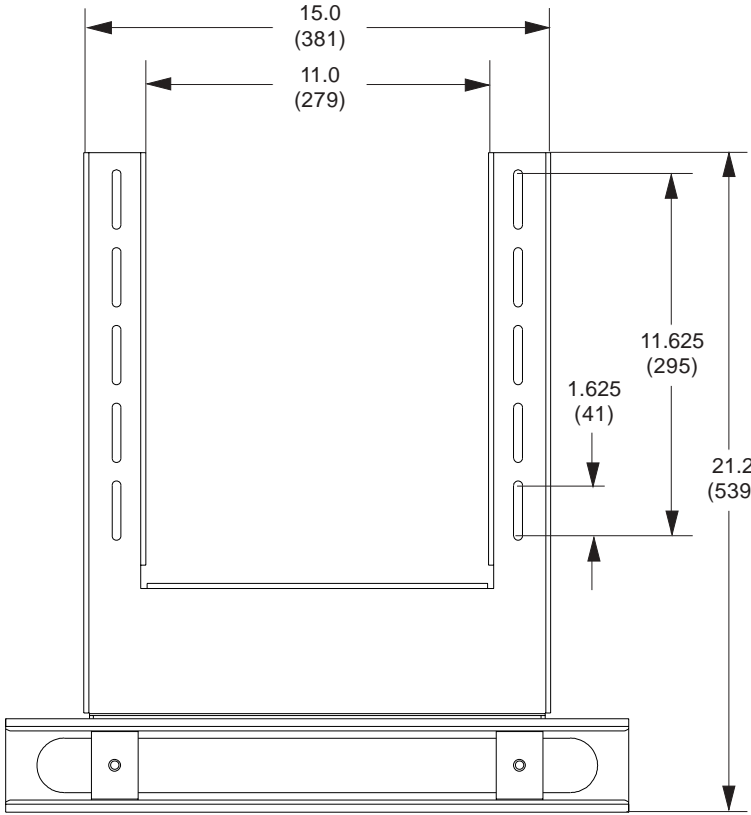
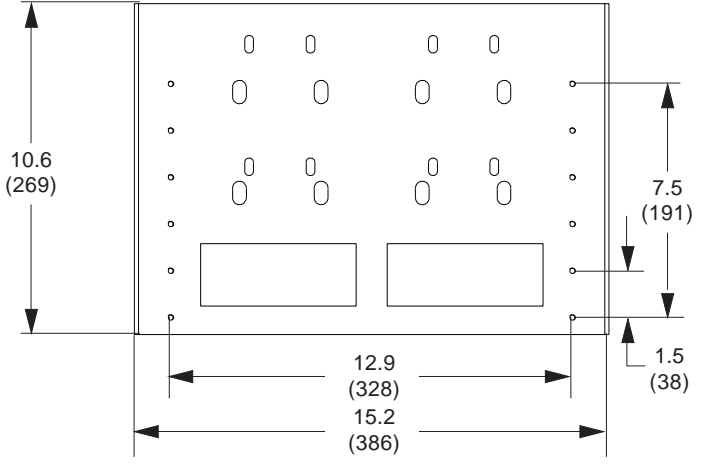
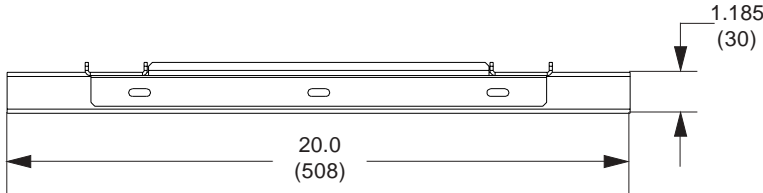

Side View