

**Installation and Assembly - Universal Articulating  
Swivel Double-Arm for 42" - 60" Plasma Screens**

**Models: PLAV70-UNLP-GB, PLAV70-  
UNLP-GS**



This product is UL Listed. It must be  
installed by a qualified professional  
installer.

**Maximum UL Load Capacity: 200 lb (91 kg)**

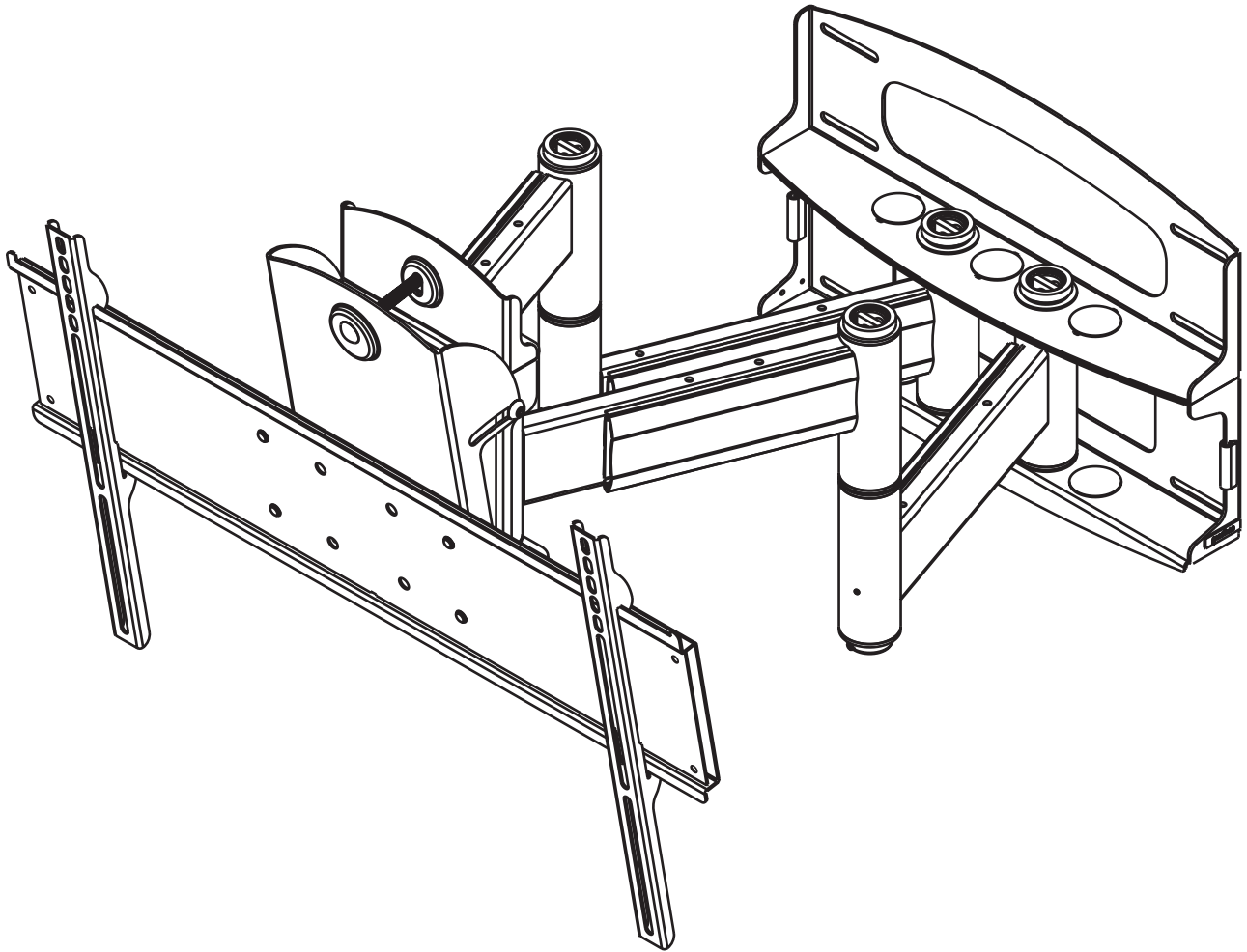

**Read instruction sheet before you start installation and assembly.**

## ⚠ WARNING

- Do not begin to install your Peerless product until you have read and understood the instructions and warnings contained in this Installation Sheet. If you have any questions regarding any of the instructions or warnings, please call Peerless customer care at 1-800-729-0307.
- This product should only be installed by a qualified professional.
- Make sure that the supporting surface will safely support the combined load of the equipment and all attached hardware and components.
- Never exceed the Maximum UL Load Capacity of 200 lb (91 kg).
- Do not attach directly to a metal stud wall. Use of a triple stud WSP wall plate is required for attachment to metal studs (contact customer care). Metal stud installation is not UL evaluated.
- If mounting to wood wall studs, make sure that mounting screws are anchored into the center of the studs. Use of an "edge to edge" stud finder is highly recommended.
- Always use an assistant or mechanical lifting equipment to safely lift and position equipment.
- Tighten screws and nuts firmly, but do not overtighten. Overtightening can damage the items, greatly reducing their holding power.

**IMPORTANT!** Certain types of walls require additional mounting hardware...

WALL CONSTRUCTION	ADDITIONAL HARDWARE REQUIRED
Wood Stud, Wood Beam	none
Concrete	none
Metal stud	WSP716, WSP716-S, WSP724, or WSP724-S
Other or unsure?	Contact Customer Care

**IMPORTANT!** Turn to the appropriate page for your wall installation.

**Installations:**

To Wood Stud Walls .....	page 6
To Concrete Walls .....	page 7

### Tools Needed for Assembly

- stud finder ("edge to edge" stud finder is recommended)
- drill
- 7/32" drill bit for wood studs
- 5/16" masonry drill bit for concrete
- 7/16" socket wrench with extension (recommended)
- level
- phillips screwdriver
- 3/4" open-end wrench

### Accessories

- External Wall Plate (WSP716, WSP716-S, WSP724, WSP724-S)  
(Metal Stud not evaluated by UL)

# Wall Mount Parts List

Before you start make sure all parts listed are included with your product.

DESCRIPTION	QTY.	PLAV70-UNLP-GB PART #	PLAV70-UNLP-GS PART #
A wall plate	1	201-P1040	201-C4040
B tilt-roll assembly	1	201-P1042	201-C4042
C arm assembly	1	201-P1044	201-C4044
D wall support arm axle	2	201-1041	201-1041
E vinyl trim	3	600-1012	600-1012
F M10 x 1.5 x 15 mm screw bolt	8	520-9262	520-9262
G .505 x .75 x .062" nylon washer	1	540-1074	540-1074
H tilt adjustment knob	1	560-0108	560-0108
I carriage bolt 3/8"-16 x 3.25"	1	520-1315	520-1315
J 1.525 x 2 x .062" delrin washer	4	540-1070	540-1070
K #8-32 x .375" socket head cap screw	2	520-1210	520-1210
L plastic finishing cap	6	590-1123	590-1123
M holding pin	2	580-1166	580-1166
N retainer plug	2	590-1007	590-1007
O 5/16 x 3" wood screw	8	520-1243	520-1243
P .250 x 1 x .068" washer	8	540-1063	540-1063
Q 9/64" allen wrench	1	560-9728	560-9728
R cable management clips	8	590-1166	590-1166
S cable tie	8	590-1168	590-1168
T 36" polyester mesh sleeve	2	600-1015	600-1015
U 6 mm allen wrench	1	560-9716	560-9716
V 10 mm allen wrench	1	560-9727	590-0097
W anchor	8	590-1025	590-1025

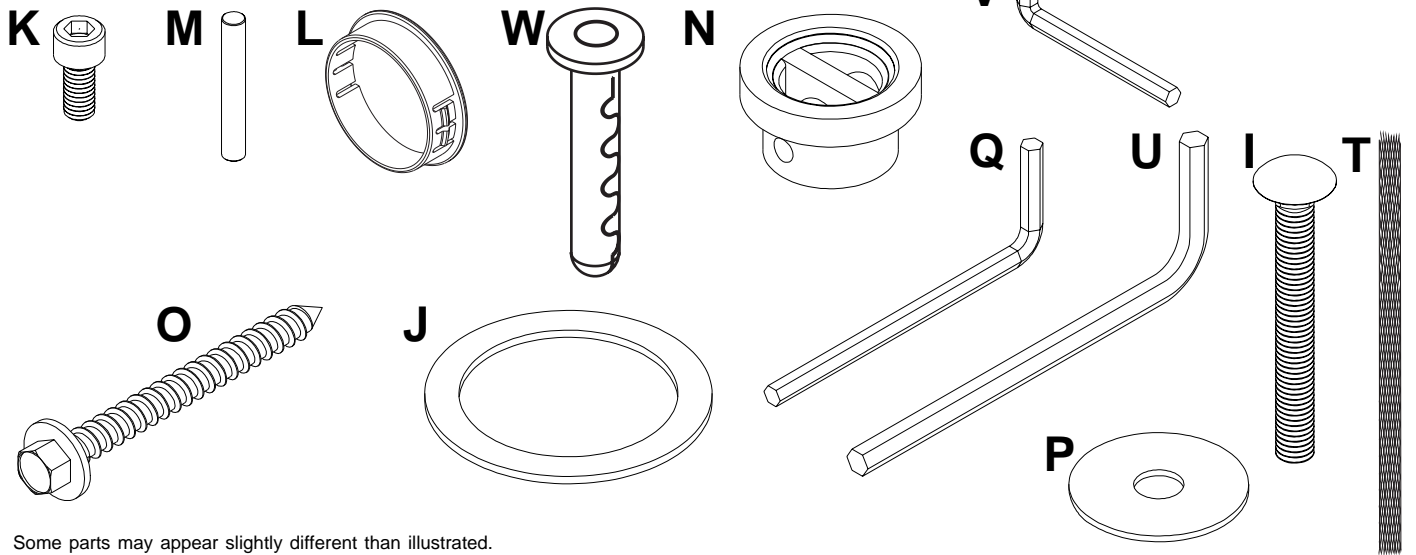
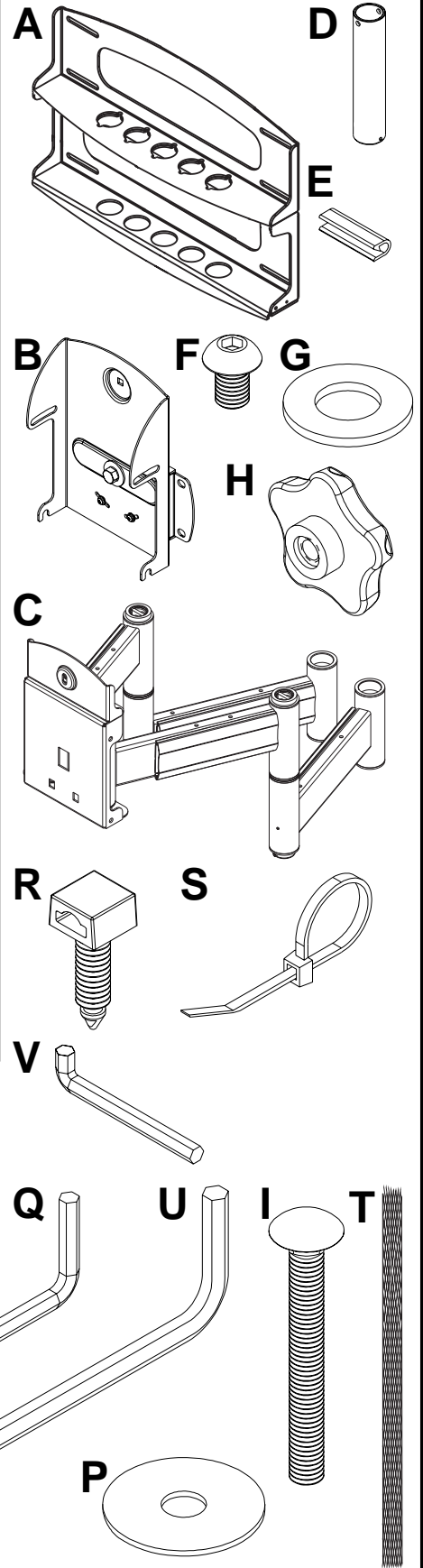

Some parts may appear slightly different than illustrated.

Before you begin, make sure all parts shown are included with your product.

## Adapter Bracket Parts List

Description	Qty	PLAV70-UNLP-GB	PLAV70-UNLP-GS
		Part #	Part #
<b>AA</b> adapter bracket	1	201-P1110	201-C4110
<b>BB</b> shallow adapter bracket	2	200-P1754	200-C4755
<b>CC</b> deep adapter bracket	2	200-P1750	200-C4751
<b>DD</b> allen wrench	1	560-0072	560-0072

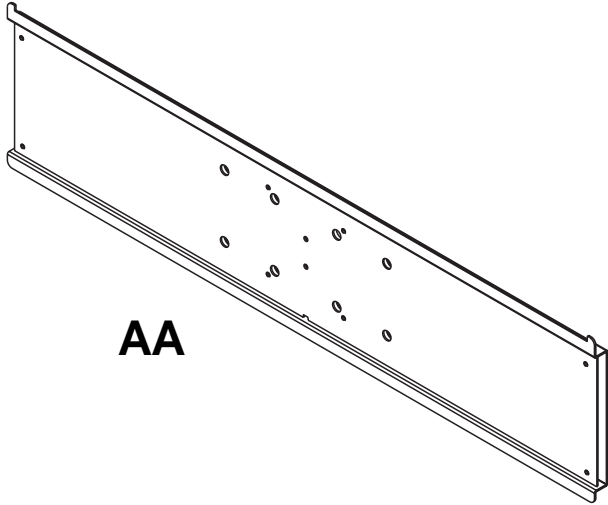

**AA**

**BB**



**CC**

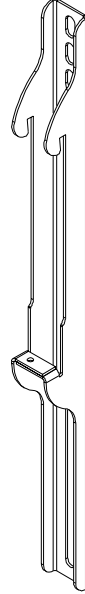

**DD**

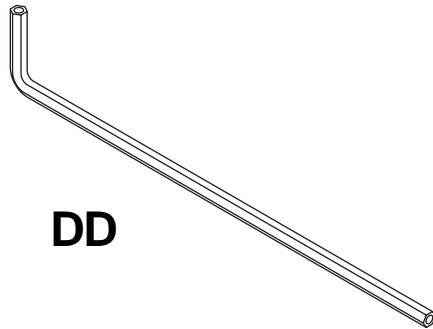

# Phillips Adapter Bracket Fasteners



M4 x 12 mm (6)  
504-9013

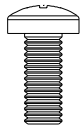

M5 x 12 mm (4)  
520-1027

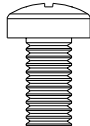

M6 x 12 mm (4)  
520-1128

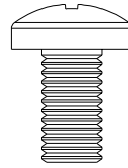

M8 x 16 mm (6)  
520-9257

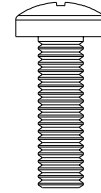

M6 x 20 mm (4)  
520-9402



M5 x 25 mm (4)  
520-9543



M4 x 25 mm (4)  
504-1015

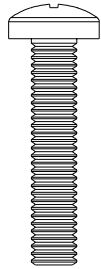

M6 x 30 mm (4)  
510-9109

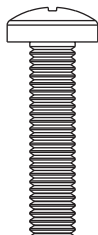

M6 x 25 mm (4)  
520-1208

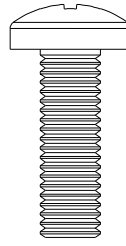

M8 x 25 mm (4)  
520-1031

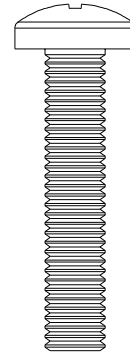

M8 x 40 mm (4)  
520-1136

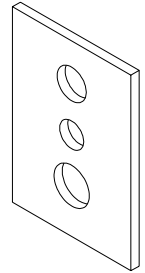

multi-washer (6)  
580-1036

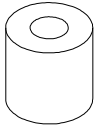

I.D. 5.6 mm (4)  
540-1057

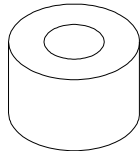

I.D. 8.7 mm (4)  
540-1059

## Installation to Wood Stud Wall

### ⚠ WARNING

- Installer must verify that the supporting surface will safely support the combined load of the equipment and all attached hardware and components.
- Tighten wood screws so that wall plate is firmly attached, but do not overtighten. Overtightening can damage the screws, greatly reducing their holding power.
- Never tighten in excess of 80 in. • lb (9 N.M.).
- Do not attach directly to a metal stud wall. Use of a triple stud WSP wall plate is required for attachment to metal studs (contact customer care). Metal stud installation is not UL evaluated.
- Make sure that mounting screws are anchored into the center of the stud. The use of an "edge to edge" stud finder is highly recommended.
- Hardware provided is for attachment of mount through standard thickness drywall or plaster into wood studs. Installers are responsible to provide hardware for other types of mounting situations.
- Never exceed the Maximum UL Load Capacity of 200 lb (91 kg).

- 1 Wall plate (**A**) can be mounted to two studs that are 16" apart. Use a stud finder to locate the edges of the studs. Use of an edge-to-edge stud finder is highly recommended. Based on their edges, draw a vertical line down each stud's center. Place wall plate on wall as a template. The top mounting slots should be located .43" below the desired screen center. Level plate, and mark the center of the eight mounting holes. Make sure that the mounting holes are on the stud centerlines. Drill eight 7/32" dia. holes 3" deep. Make sure that the wall plate is level, secure it using eight 5/16 x 3" wood screws (**O**) and washers (**P**).

*Skip to step 2 on page 8.*

### ⚠ WARNING

- Never mount this product to metal studs without the required accessory.

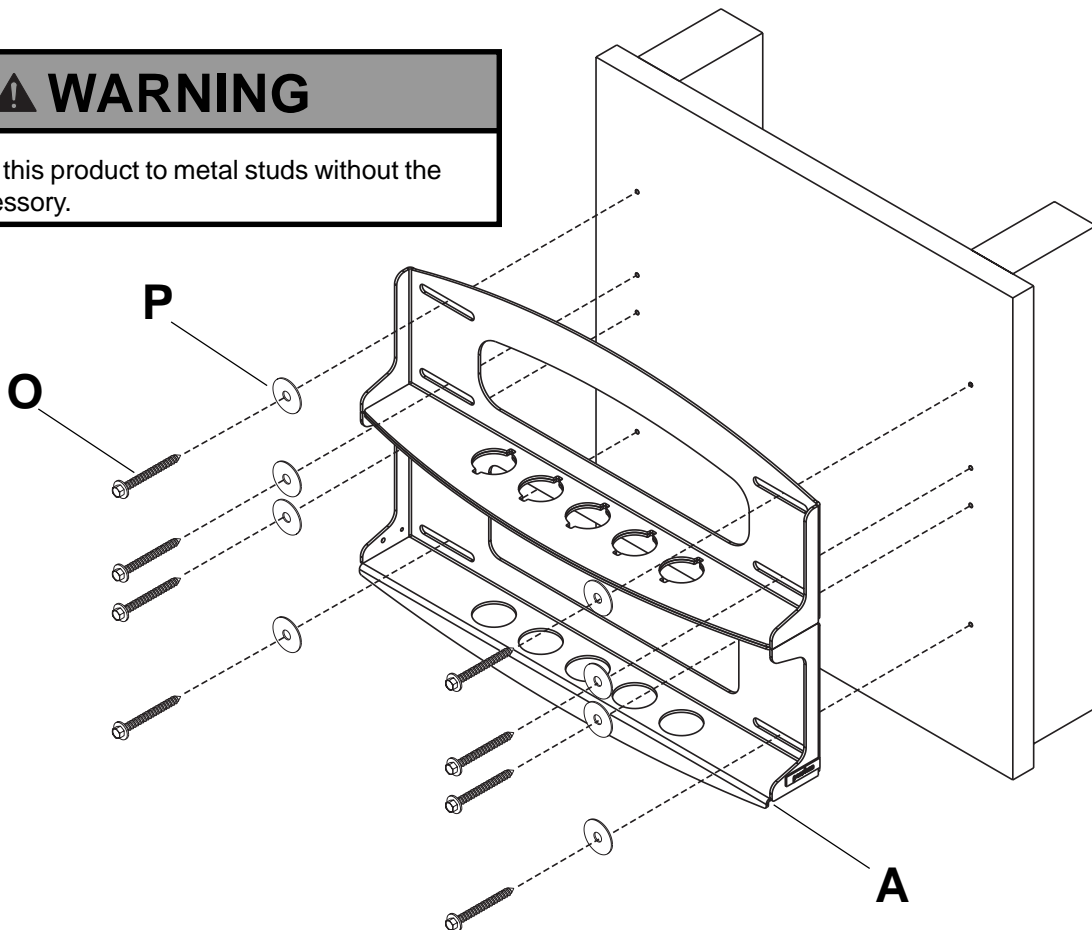

# Installation to Concrete Wall

## ⚠ WARNING

- Concrete must be 2000 psi density minimum. Lighter density concrete may not hold concrete anchor.
- Make sure that the supporting surface will safely support the combined load of the equipment and all attached hardware and components.
- Never exceed the Maximum UL Load Capacity of 200 lb (91 kg).

**IMPORTANT! Concrete must be 2000 psi density minimum.**

- 1** Use wall plate (A), making sure that it is level, as a template to mark holes. The top mounting slots should be located .43" below the desired screen center. Use the masonry bit to drill 5/16" (8 mm) dia. holes to a minimum depth of 3" (76 mm). Insert anchors (W) in holes flush with wall as shown (right). Place wall plate (A) over anchors (W) and secure with 5/16 x 3" wood screws (O) and washers (P).

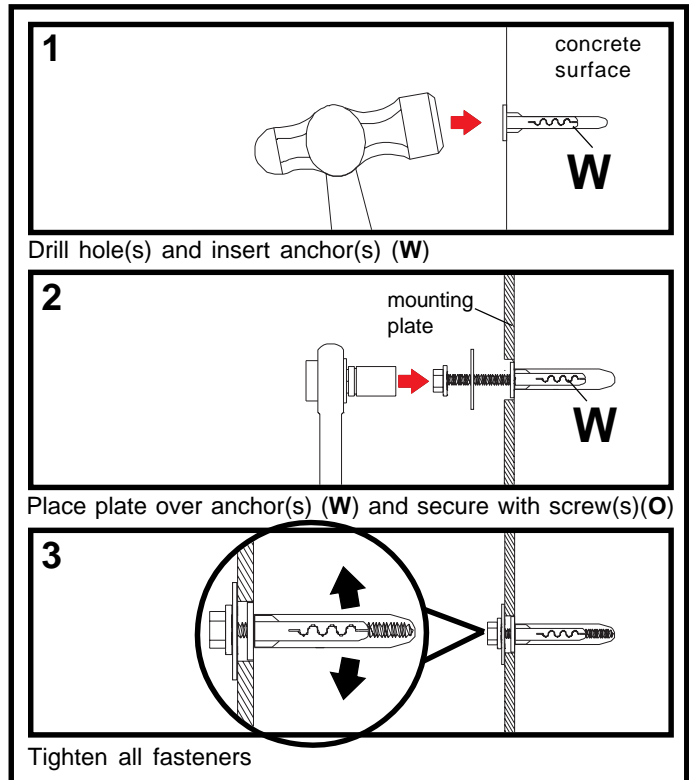

## ⚠ WARNING

- Tighten wood screws so that wall plate is firmly attached, but do not overtighten. Overtightening can damage screws, greatly reducing their holding power.
- Never tighten in excess of 80 in • lb (9 N.M.).

## ⚠ WARNING

- Always attach concrete expansion anchors directly to load-bearing concrete.
- Never attach concrete expansion anchors to concrete covered with plaster, drywall, or other finishing material. If mounting to concrete surfaces covered with a finishing surface is unavoidable, the finishing surface must be counterbored as shown below. If plaster/drywall is thicker than 5/8", custom fasteners must be supplied by installer (not UL evaluated).

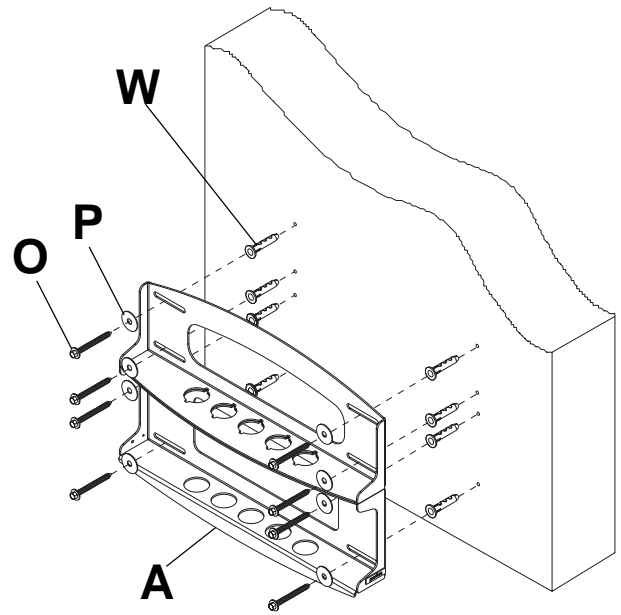

INCORRECT

CORRECT

CUTAWAY VIEW

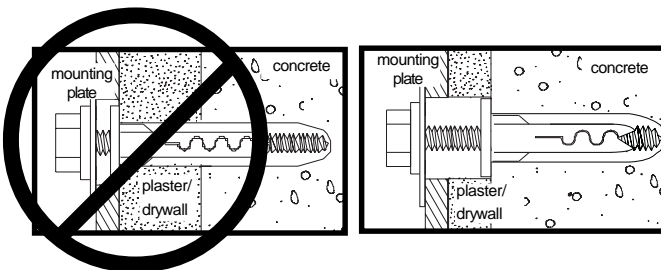

# ⚠ WARNING

- If you are uncertain that product is properly installed, call customer care.

**2** **Note:** There are three mounting positions. The center position is shown right. Arm assemblies must be mounted with one mounting hole separating them. Slide washers (J) over wall support arm axles (D). Next, insert plastic caps (N) into axles. Then, insert holding pins (M) into axles. See detail 1.

**2-1** Place arm assembly (C) with washers (J) into wall plate (A). Insert axle assemblies shown in detail 1 through wall plate (A), arm assembly (C), and washers (J). Lock axles in place by aligning holding pins (M) with notches shown in detail 2.

**2-2** Insert socket cap screws (K) into hole at bottom of wall support arm axles (D) as shown in detail 3. Tighten screw using 9/64" allen wrench (Q).

**Note:** Fit of axles (D) into wall plate (A) and arm assembly (C) will be tight. Gently tap into place with a hammer if necessary.

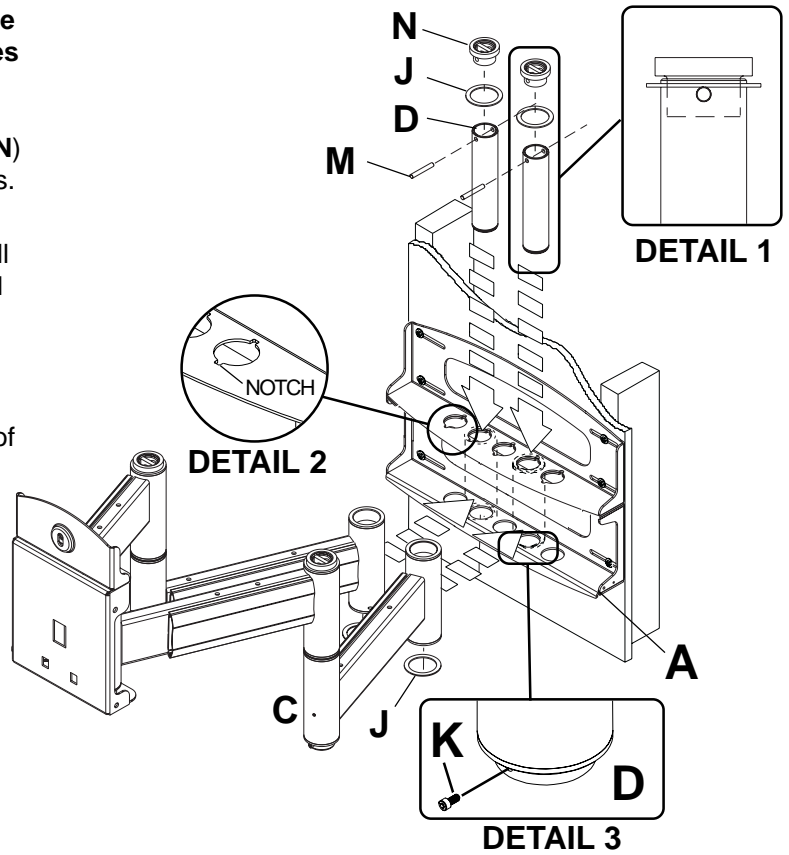

**3** **To route cables through cord management channels:** Slide one mesh sleeve (T) over each cable. Use cable ties (S) to tighten mesh sleeves to cables.

**3** **To route cables using cable management clips:** Snap eight cable management clips (R) into both swing arms (C) as shown in figure 3.2. Cable ties (S) are used with clips for cord management.

**3-1** Pull cords through cord management channels, leaving enough slack to allow full range of movement for swing arm assembly (C) as shown in figure 3.1.

**3-1** Slide one mesh sleeve (T) over each cable. Use cable ties (S) to tighten mesh sleeves to cables.

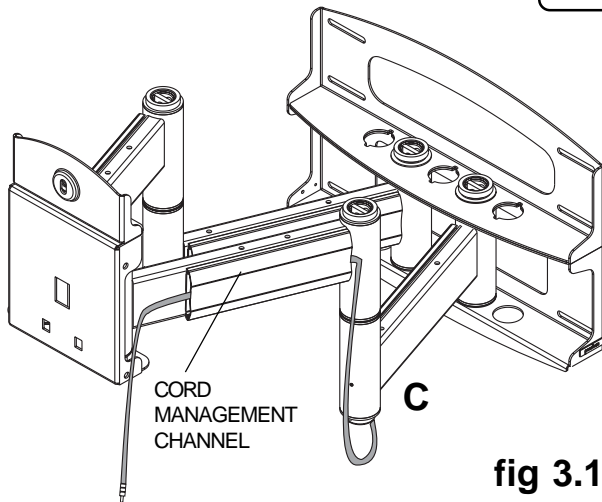
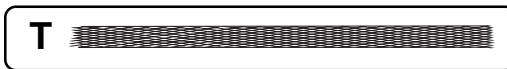

fig 3.1

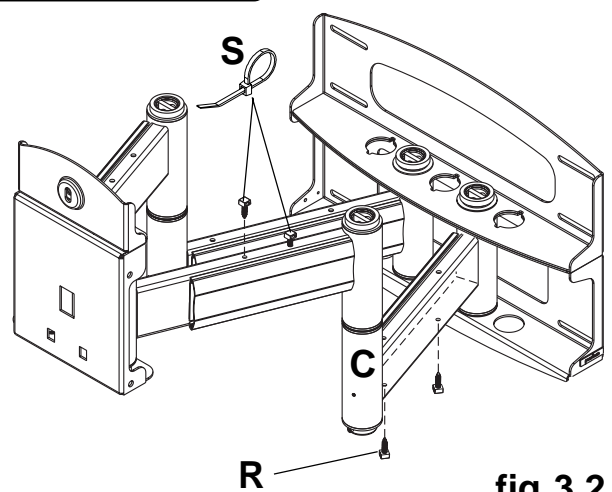
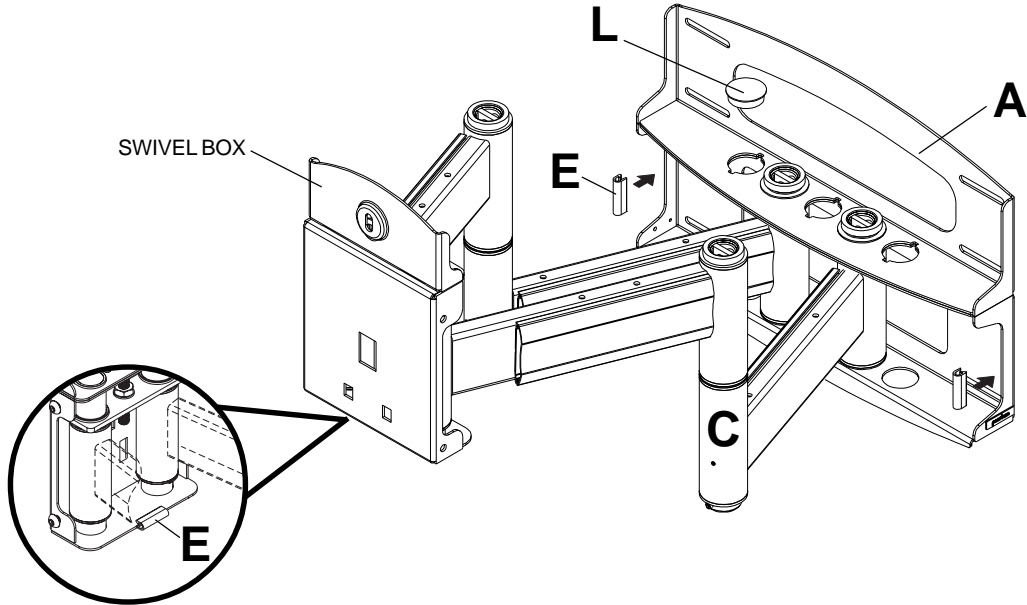

fig 3.2



**4** Attach two pieces of vinyl trim (E) to wall plate (A). Next, attach one piece of vinyl trim to bottom of swivel box on arm assembly (C).

**4-1** Insert one finishing cap (L) into each unused hole of wall plate (A).



**5** Insert and tape carriage bolt (I) into top hole of tilt-roll assembly (B). Attach tilt-roll assembly to adapter bracket (AA) with four M10 socket screws (F). Tighten screws using 6 mm allen wrench (U).

## CAUTION

- Do not overtighten screws! Overtightening may hinder roll option.

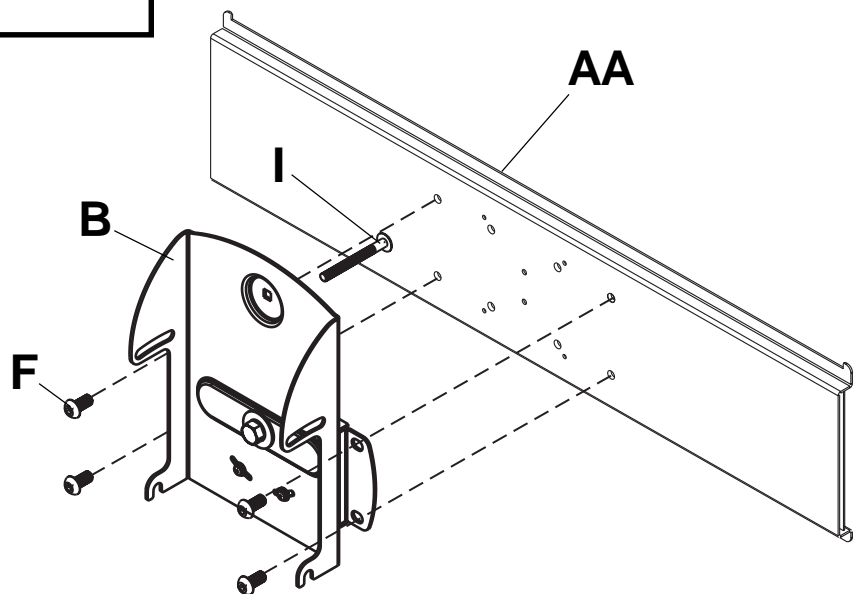

## ⚠ WARNING

- Use an assistant or mechanical lifting equipment to safely lift and position the plasma TV.

**6** Insert two M10 screws (F) into swivel box on arm assembly (C) as shown. Leave approx. 1/4" of exposed thread.

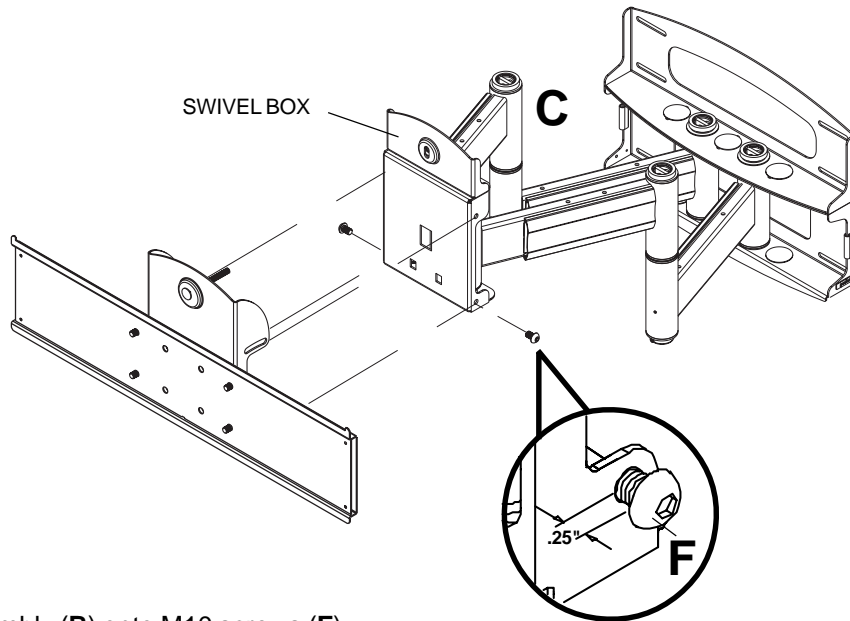

**6-1** Hook tilt-roll assembly (B) onto M10 screws (F). Insert carriage bolt (I) into slot of swivel box as shown in figure 6.1. Install nylon washer (G) and tilt adjustment knob (H).

**6-2** Install remaining two M10 screws (F) as shown in figure 6.2. **HAND TIGHTEN** all four M10 screws to allow for tilt adjustment. Remove tape from carriage bolt (I). For tilt adjustment, gently push back on the top of plasma to relieve pressure on knob. Adjust tilt to desired position and tighten tilt adjustment knob (H), then securely tighten all four M10 screws (F) using 6 mm allen wrench (U).

## CAUTION

- After tilt is adjusted, all fasteners must be tightened. Failure to do so will result in damage to the mount.

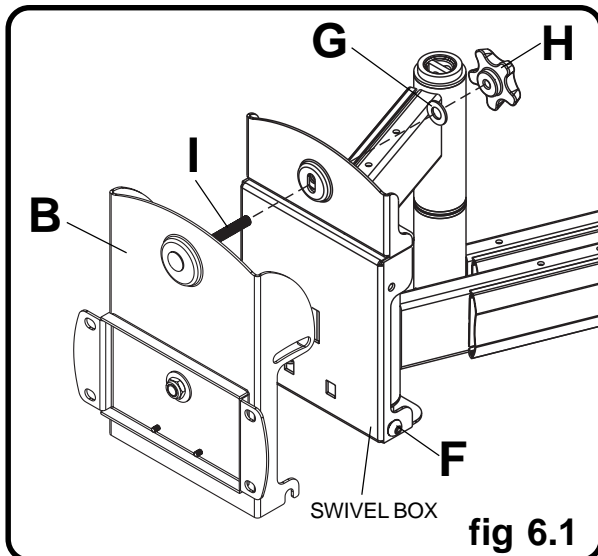

Adapter bracket not shown for clarity.

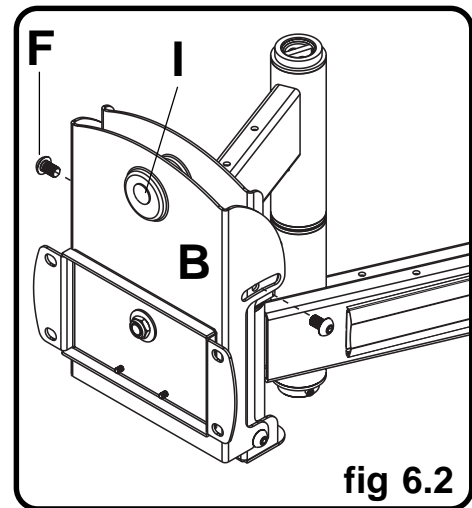

Adapter bracket not shown for clarity.

# Installing Adapter Brackets

Refer to **Screen Compatibility Chart** to determine the proper fasteners to use.

- 7** To prevent scratching the screen, set a cloth on a flat, level surface that will support the weight of the screen. Place screen face side down. If screen has knobs on the back, remove them to allow the adapter brackets to be attached. Place adapter brackets (**BB or CC**) on back of screen, align to holes, and center on back of screen as shown in figure 7.1. Attach the adapter brackets to the back of the screen using the appropriate combination of screws, multi-washers, and spacers as shown in figure 7.3.

**Note:** Top and bottom holes must always be used.

Verify that all holes are properly aligned, and then tighten screws using a phillips screwdriver.

**⚠ WARNING**

- Tighten screws so adapter brackets are firmly attached. Do not tighten with excessive force. Overtightening can cause stress damage to screws, greatly reducing their holding power and possibly causing screw heads to become detached. Tighten to 40 in. • lb (4.5 N.M.) maximum torque.

**Notes:**

- The number of fasteners used will vary, depending upon the type of screen.
- Multi-washers and spacers may not be used, depending upon the type of screen.
- Use the corresponding hole in the multi-washer that matches your screw size as shown in figure 7.2.

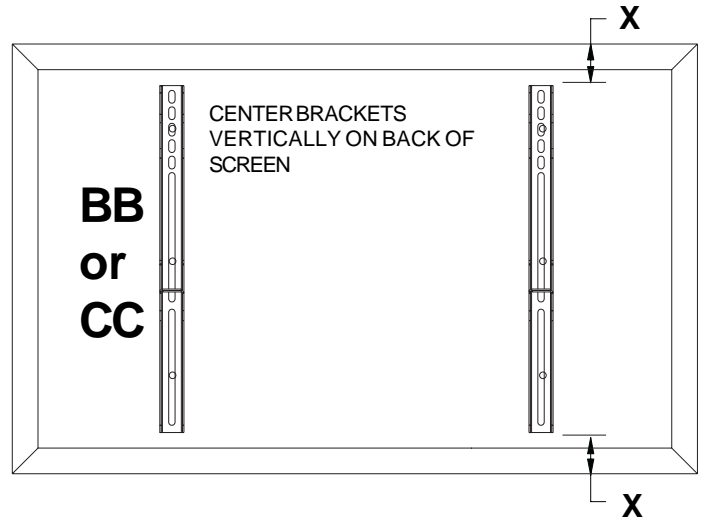
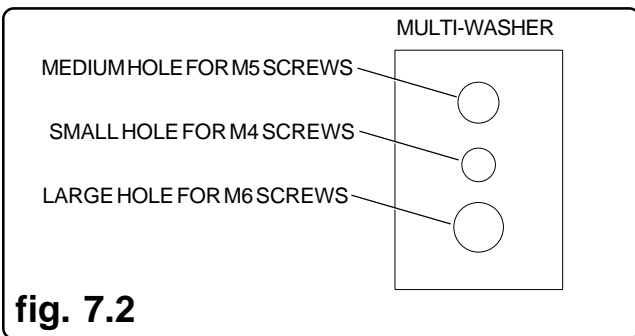

**fig 7.1**

**Note:** "X" dimensions should be equal.

**⚠ WARNING**

- If screws don't get three complete turns in the screen inserts or if screws bottom out and bracket is still not tightly secured, damage may occur to screen or product may fail.



**fig. 7.2**

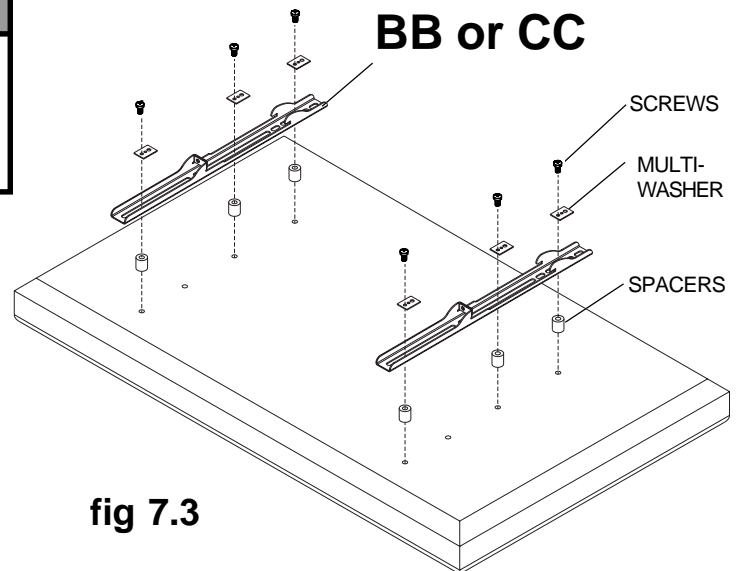

**fig 7.3**

## Mounting and Removing Flat Panel Screen

Refer to mount instruction sheet for attachment of adapter bracket to mount.

- Hook adapter brackets (**BB or CC**) onto adapter bracket (**AA**), then slowly swing screen in as shown. Turn screws clockwise at least six times to prevent screen from being removed as shown in detail 4. Tighten using allen wrench (**DD**). Screen can be adjusted horizontally if desired.

**Note:** To lock the screen down, tighten screws to adapter bracket as shown in detail 4.

To remove screen from mount, loosen screws, swing screen away from mount, and lift screen off of mount.

### ⚠ WARNING

- Always use an assistant or mechanical lifting equipment to safely lift and position the plasma television.

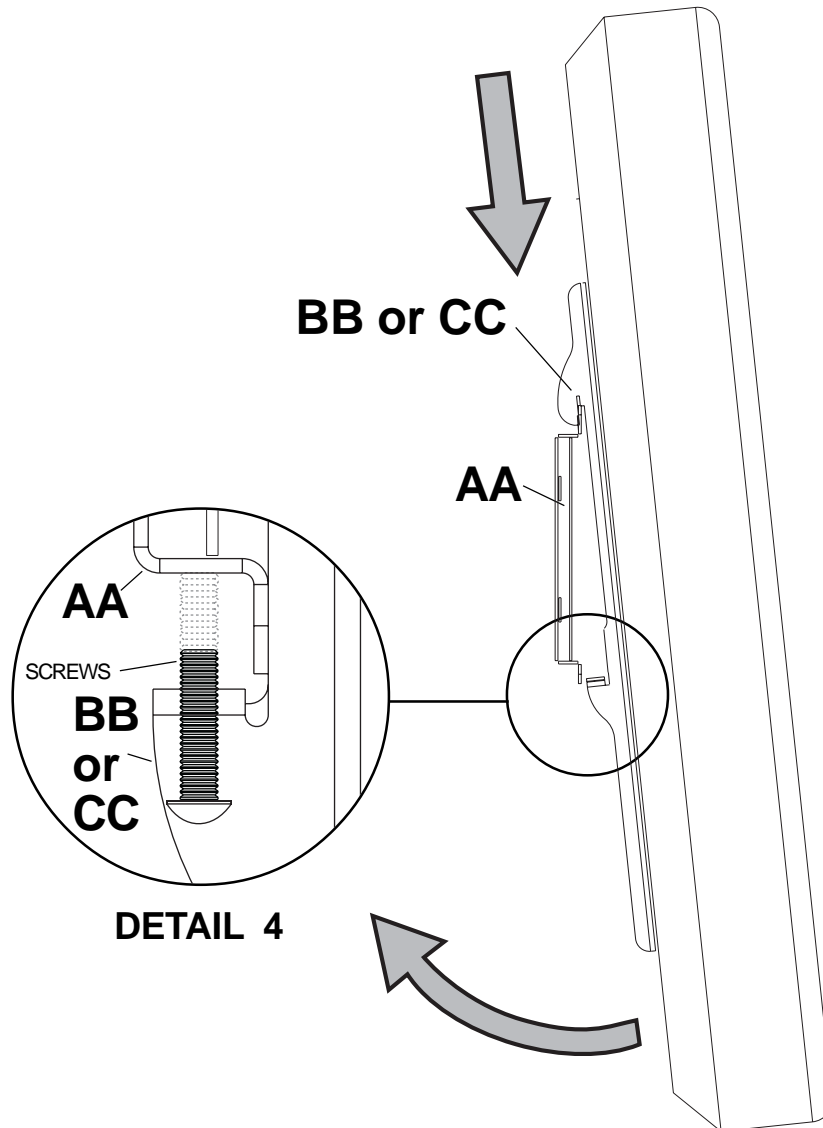

**9** Depending on the specific size & weight of the plasma, articulating swing arm may be angled at different positions, causing plasma to appear to lean sideways at different articulating positions. Tilt-roll assembly (**B**) allows plasma to be manually adjusted, so plasma can be horizontal at all positions. To adjust, gently rotate plasma by hand to desired position.

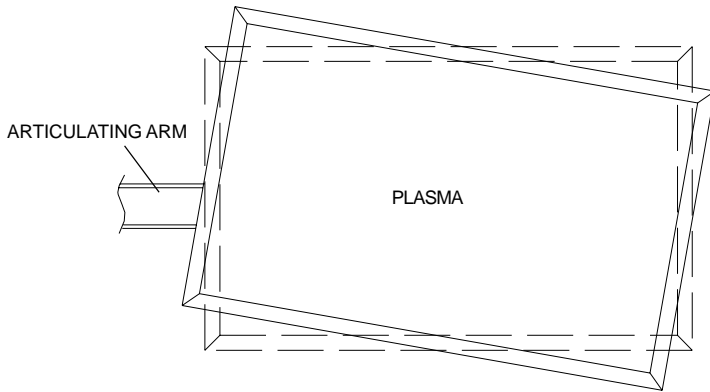

**9-1** If it is too difficult to adjust roll of plasma, loosen screws shown in figure 9.1 using a phillips screwdriver.

**IMPORTANT!** Do not loosen or tighten screws more than 1/8 turn.

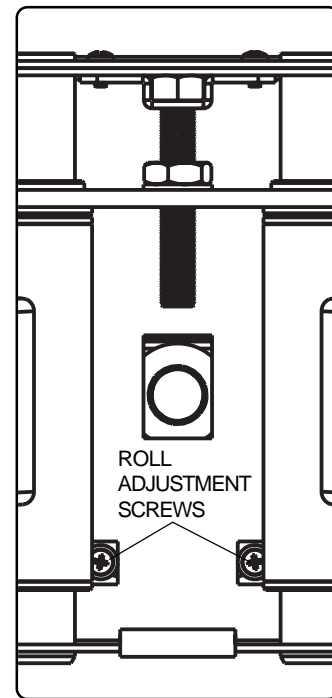

**fig 9.1**

**10** Position of screen may be adjusted vertically up to .79" in each direction by doing the following:

- To raise screen, turn hex nut shown in figure 10.1 clockwise with 3/4" open-end wrench (not provided).
- To lower screen, turn hex nut shown in figure 10.1 counterclockwise with 3/4" open-end wrench (not provided).

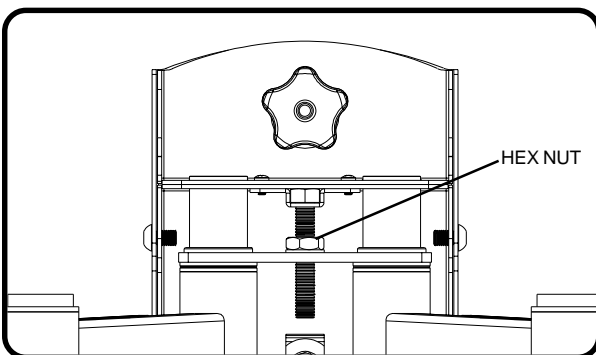

**fig 10.1**