

TECHNICAL DATA SHEET - Articulating Wall Arm for 32" - 50" Plasma and LCD Flat Panel Screens



MODELS: PLA 50, PLA 50-S, PLA 50-UNL, PLA 50-UNL-S, PLA 50-UNLP, PLA 50-UNLP-S, PLA 50-UNLP-GB, PLA 50-UNLP-GS

Offer the best view in the room with ability to swing, tilt or articulate the most popular sizes of plasma and LCD screens. Self-lubricating bushings enable the arms to smoothly extend, while adjustable tilt and pivot position the screen to the optimal viewing angle. The **PLA 50** offers versatility for the most popular sizes of screen in a wide range of installations in lobbies, hotel rooms, boardrooms, public displays or home theaters.

Features:

- For 32" to 50" plasma and LCD screens
- New look and functionality
- Roll feature allows for easy screen leveling
- Folds flat against the wall
- Cord management keeps cords organized and out of sight
- Comes in black, silver, glossy black or glossy silver
- +10°/-5° tilt
- Up to 180° pivot
- +/-7° roll to level screen horizontally at any position
- Extends out to 29.3", retracts to 4.5" (plus thickness of required adapter plate)
- Includes mesh cord sheath and cable ties to neatly manage cords
- Mounts to two wood studs or concrete
- Universal models adapt to screens with up to 28.7" wide x 17" high mounting inserts

Accessories:

- Multi-channel speaker mount (MSA-101)
- Wire management channel (ACC 924/ ACC 926)
- PLP model adapter plates
- External Wall Plate (WSP716, WSP716-S, WSP724, WSP724-S) (Metal Stud not evaluated by UL)

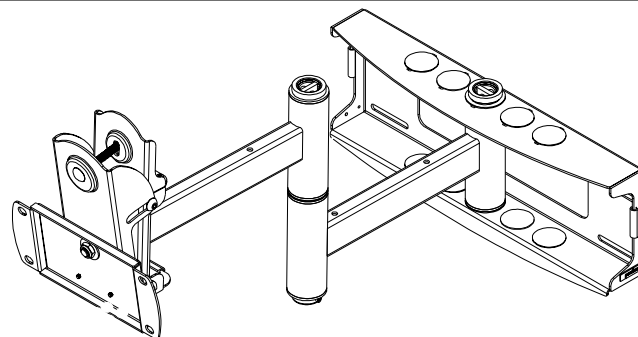

PLA 50, PLA 50-S

Dimensions:

Weight:

24.3 lb (11 kg)

Shipping weight:

28.5 lb (12.9 kg)

Maximum Load Capacity:

150 lb (68 kg)

Shipping Carton dimensions:

L= 23.125 in (587 mm)

W= 17.125 in (435 mm)

H= 7.375 in (187 mm)

PLA 50-UNL, PLA 50-UNL-S PLA 50-UNLP, PLA 50-UNLP-S, PLA 50-UNLP-GB, PLA 50-UNLP-GS

Dimensions:

Weight:

36.8 lb (17 kg)

Shipping weight:

42.9 lb (19.5 kg)

Maximum Load Capacity:

150 lb (68 kg)

Shipping Carton dimensions:

L= 31.5 in (800 mm)

W= 17.125 in (435 mm)

H= 8.625 in (219 mm)

ARCHITECTS SPECIFICATIONS

The Articulating Wall Arm shall be a Peerless model _____ and shall be located where indicated on the plans. It shall be constructed of heavy gauge cold rolled steel with 10° adjustable forward and 5° backward tilt. It shall feature +/-7 degrees of roll. The finish shall be scratch resistant Black, Silver, Glossy Black or Glossy Silver Fused Epoxy. Assembly and installation shall be done according to instructions provided by the manufacturer.

Peerless Industries, Inc.
3215 W. North Ave. Melrose Park, IL 60160
708-865-8870 800-865-2112 Fax 708-865-2941
www.peerlessindustries.com

ISSUED: 06-19-06 SHEET NO: 202-9532-2 12-06-06

©2006 Peerless Industries, Inc. All rights reserved.
Peerless is a registered trademark of Peerless Industries, Inc.
All other brand and product names are trademarks or registered trademarks of their respective owners.

TECHNICAL DATA SHEET

MODELS: PLA 50, PLA 50-S, PLA 50-UNL, PLA 50-UNL-S, PLA 50-UNLP, PLA 50-UNLP-S, PLA 50-UNLP-GB, PLA 50-UNLP-GS

Note: All dimensions are shown as inch (mm).

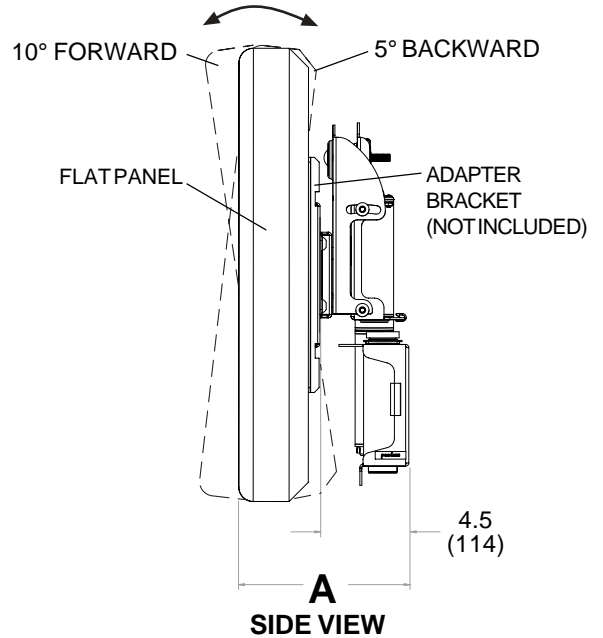
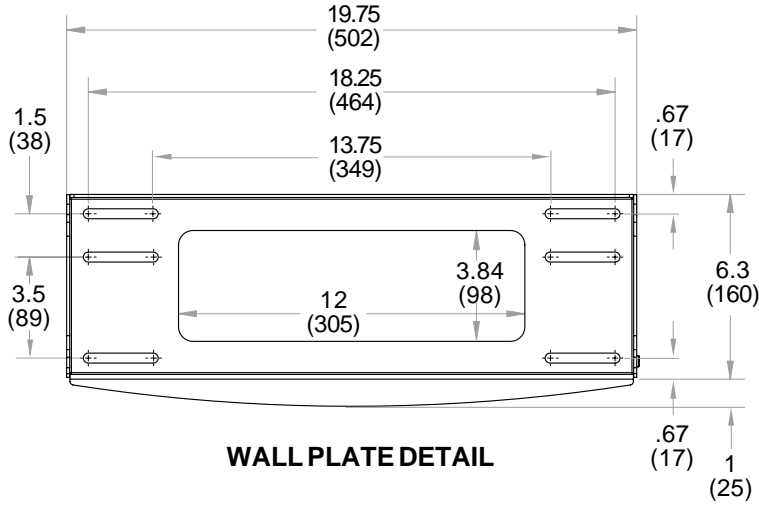

A = DEPTH OF FLAT PANEL + DEPTH OF ADAPTER BRACKET* + 4.5"

*For depth of adapter bracket refer to PLP TD sheet

CF = CENTER OF FLAT PANEL

CA = CENTER OF ADAPTER BRACKET

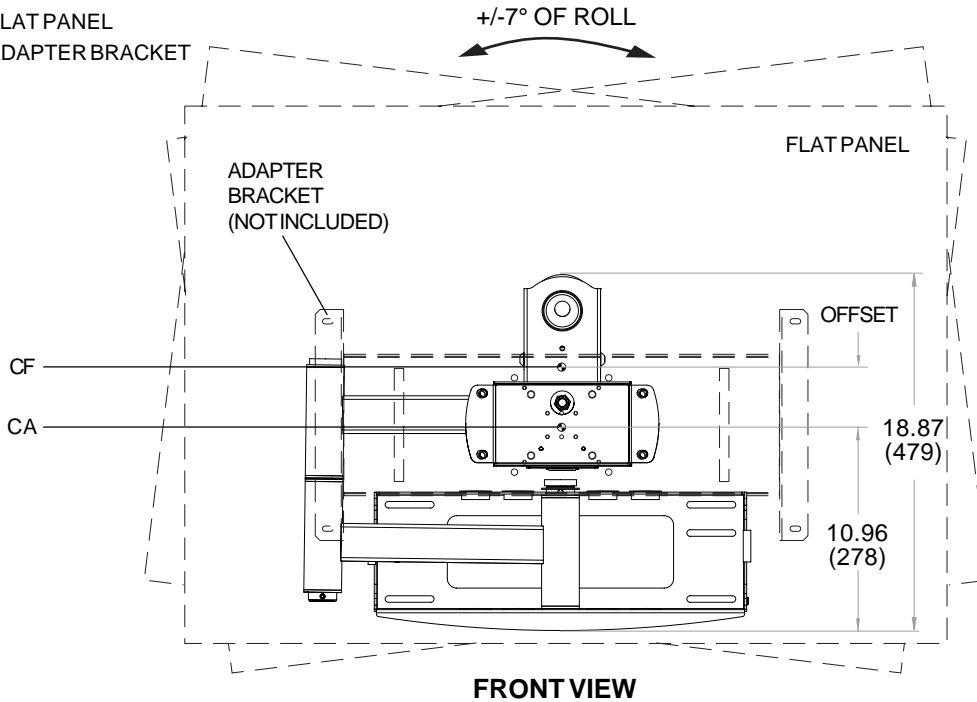

THE MINIMUM FLAT PANEL HEIGHT THAT WOULD FULLY HIDE THE MOUNT IS (10.96"(253MM) + OFFSET*) X 2.

*For offset of adapter bracket refer to PLP TD sheet

TECHNICAL DATA SHEET

MODELS: PLA 50, PLA 50-S, PLA 50-UNL, PLA 50-UNL-S, PLA 50-UNLP, PLA 50-UNLP-S, PLA 50-UNLP-GB, PLA 50-UNLP-GS

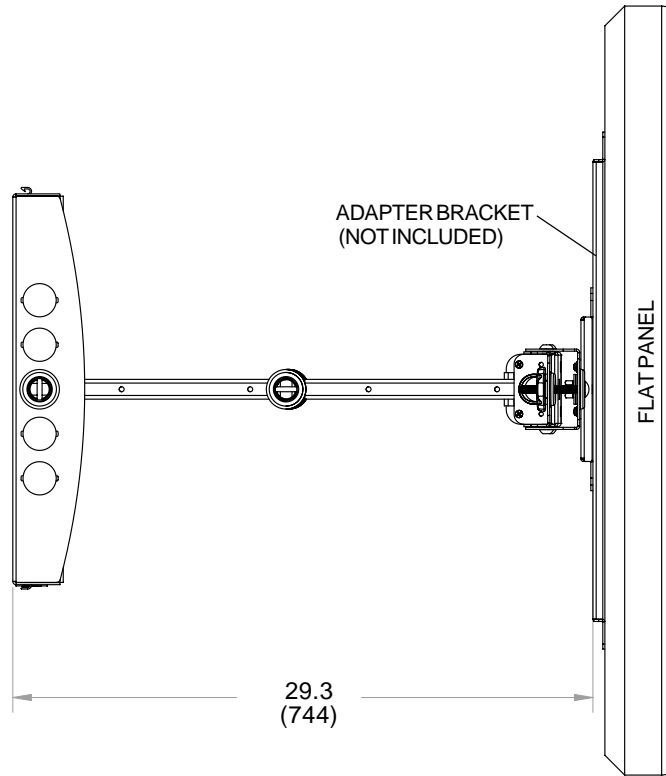

TOP VIEW (A)

THE MAXIMUM FLAT PANEL WIDTH THAT WOULD ALLOW A MOUNTED FLAT PANEL SCREEN A FULL 180 DEGREE SWIVEL IS 46" (1168 mm)

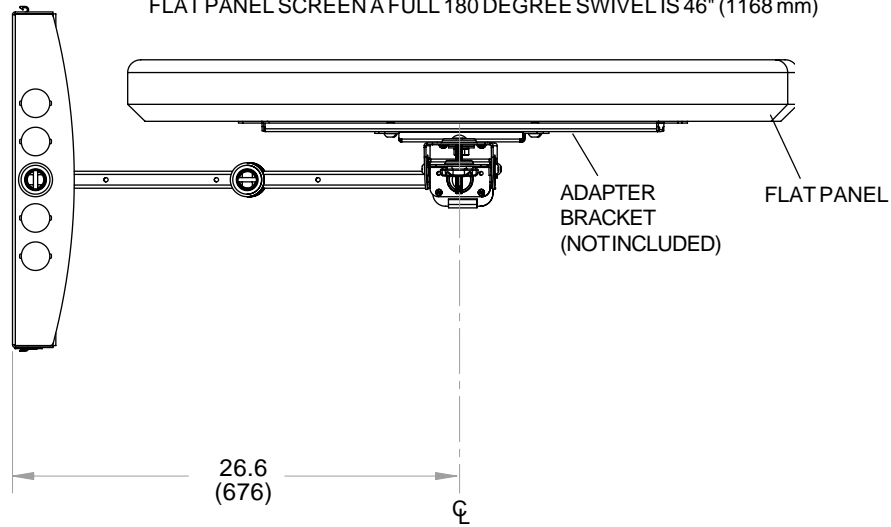

TOP VIEW (B)