

Installation and Assembly - Solid•Point™ Plasma Table Top Stand

Models: PLTBLK-PLNR42,
PLTBLK-UN-1



This product is intended for use with UL Listed products and must be installed by a qualified professional installer.

Protected by U.S. Patent number 478,088.

Maximum Load Capacity:
150 lb (68.2 kg)

Please read this information first

Read through instruction sheet and check to make sure you have all parts before beginning assembly and installation. You will need assistance to complete the final step in assembling the Table Top Stand.

TOOLS REQUIRED: Phillips head screwdriver and open end wrench.

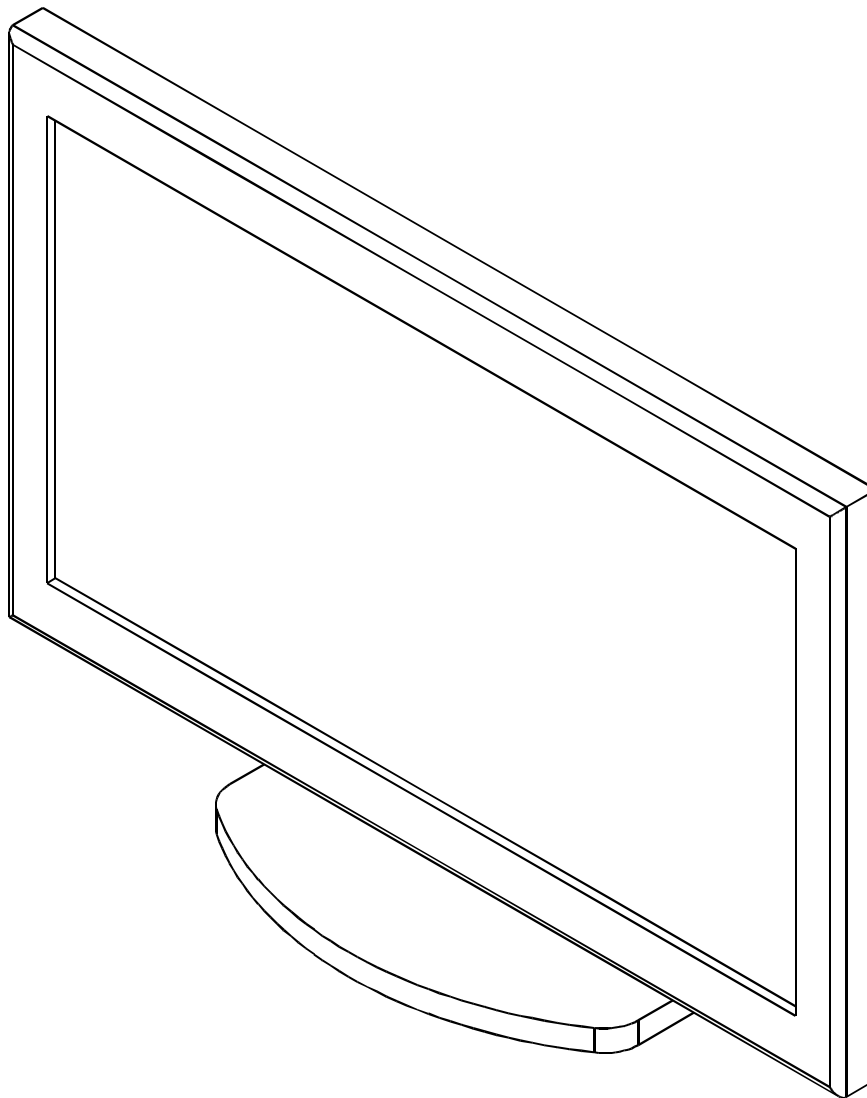

Parts List

Description	Qty.	Part No.
A base	1	600-1000
B support box	1	200-1234
C cover plate	1	200-1236
D tilt plate	1	200-1546
E tilt bracket	1	200-1237
F 5/16-18 x 2" black socket screw	4	520-1116
G .406 x .812 x .06 flat washer	4	540-9407
H 5/16-18 nut	4	530-9306
I M5 x .8 x 6 mm phillips pan head screw	6	520-9504
J M8 x 1.25 x 16 mm socket screw	2	520-9527
K 3/16 allen wrench	1	560-9713
L adhesive felt race	1	570-1035
M 1.5 OD x .403 x .0625 washer	1	540-1009
N race	1	560-0065
O #10 x 3/4 particle board screw	4	500-9006
P rubber grommet	2	530-9401
Q knob	1	560-1143
R adhesive feet	1	570-1034
S finishing cap	2	590-1123
T M10 x 1.5 x 17 mm socket serrated flange bolt	4	520-1105
U allen wrench for M10 socket bolt	1	560-9716

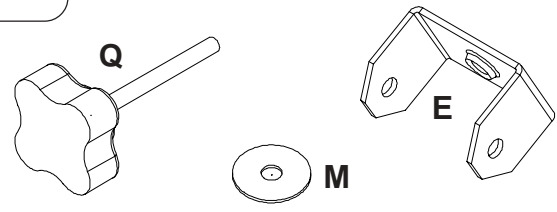
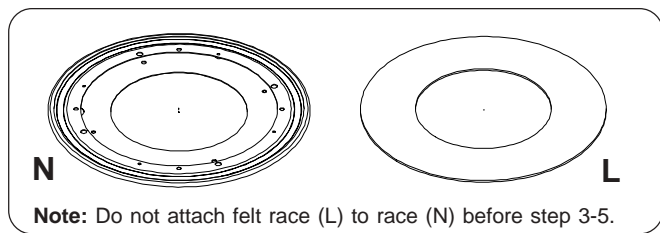
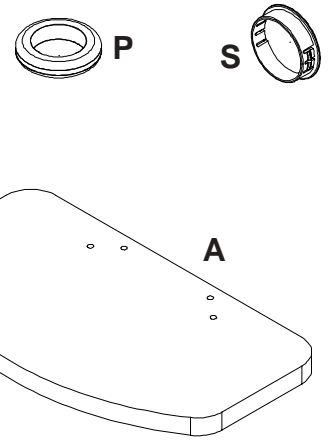
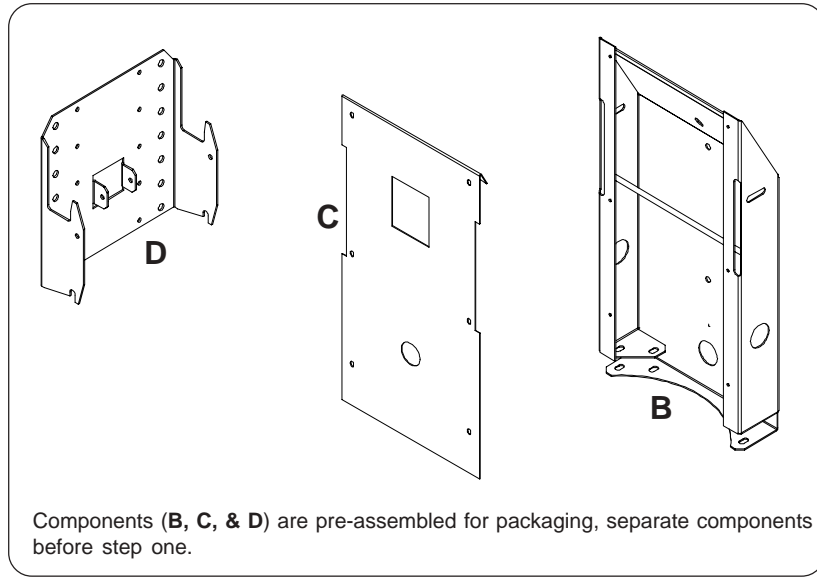
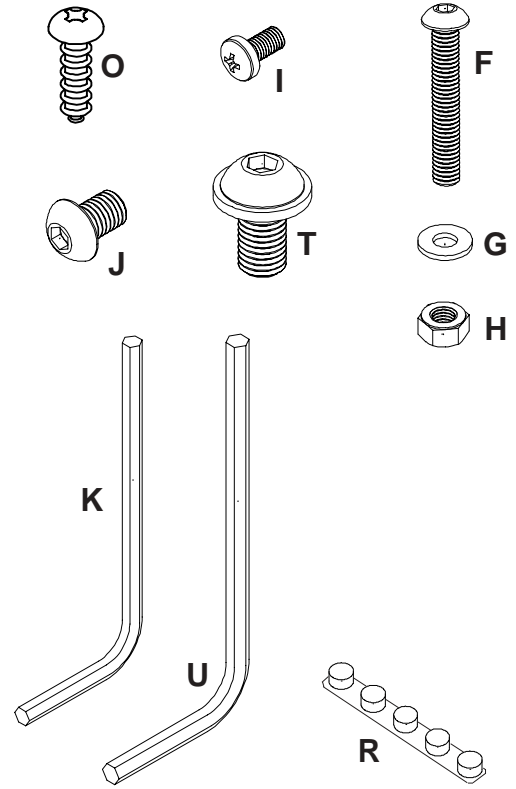

- 1** Lay support box (B) on a flat, non-scratch surface. Insert base (A) into support box (B).

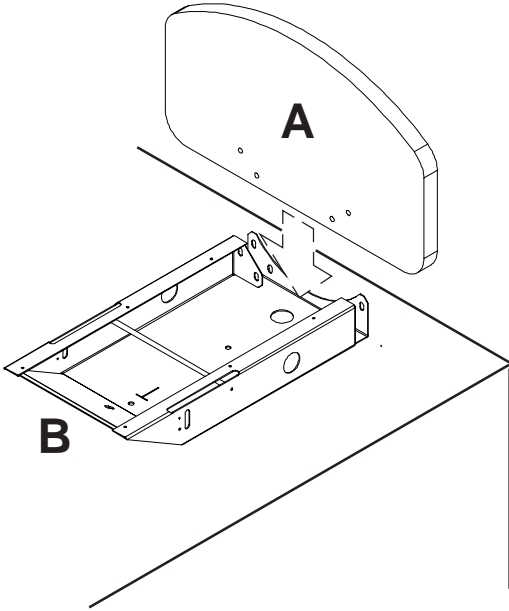

- 1-1** Fasten base (A) with four sets of bolts (F), nuts (H), and washers (G). Hand tighten fasteners. Hang base just over edge of work surface and tighten fasteners with allen wrench while holding nuts with an open end wrench.

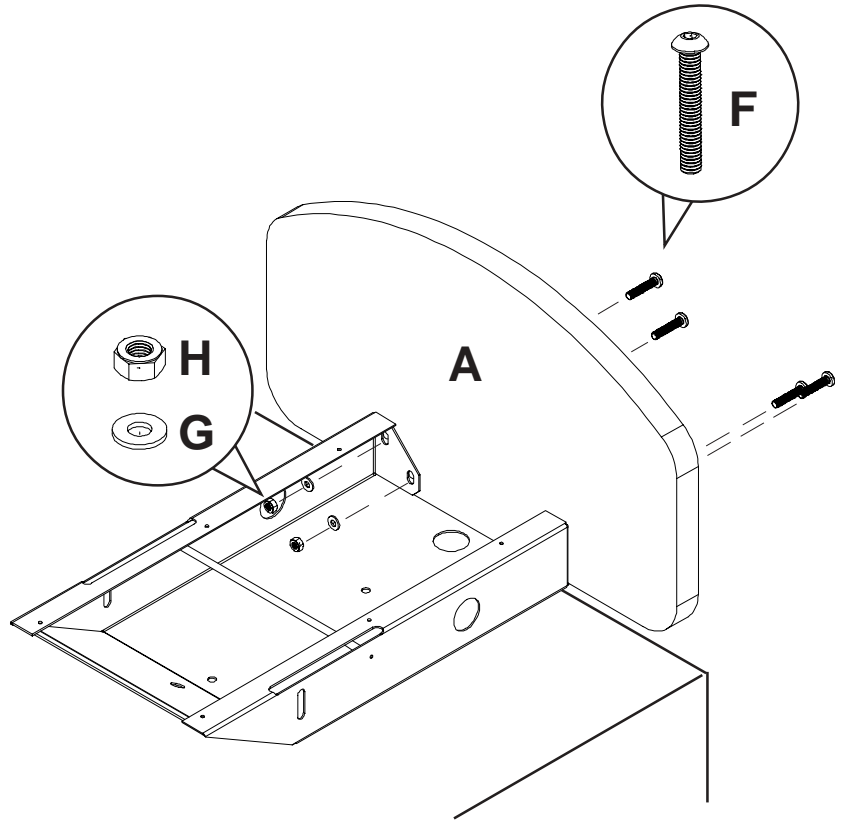

- 2** **Note:** For cord management route cords through support box (B) before attaching cover plate (C) where indicated.

Snap two grommets (P) into holes used for cord management. Snap two finishing caps (S) into unused cord management holes. Hook cover plate (C) over support box (B) and fasten with six phillips screws (I).

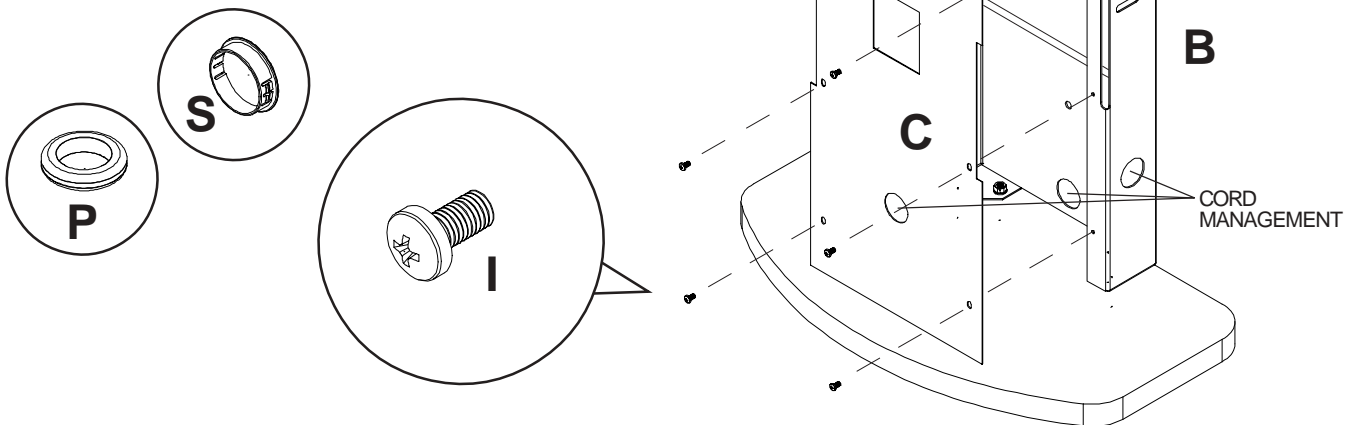

OPTIONAL: For 360° swivel, attach race as shown in step three. For no swivel, skip step three and attach adhesive feet (R) at four corners and front edge of base. Set feet back off edges about 3 inches.

3 Attach race (N) to bottom of base (A). Lay base on flat surface as shown in step 3-3.

3-1 Locate four middle holes on top of race (N) circled in Top View.

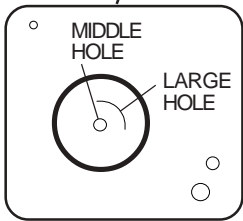
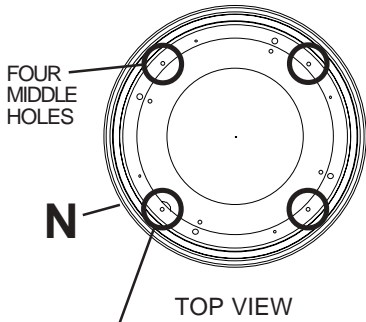

DETAIL 1

3-2 Flip race over and align one of four middle holes from top of race with large hole on bottom of race circled in Bottom View.

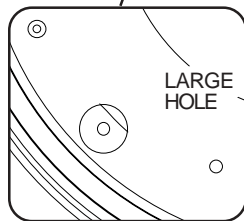
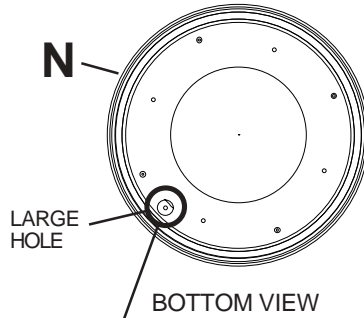

DETAIL 2

3-3 Align one large hole and middle hole with one pilot hole in base (A) and place race (N) on base.

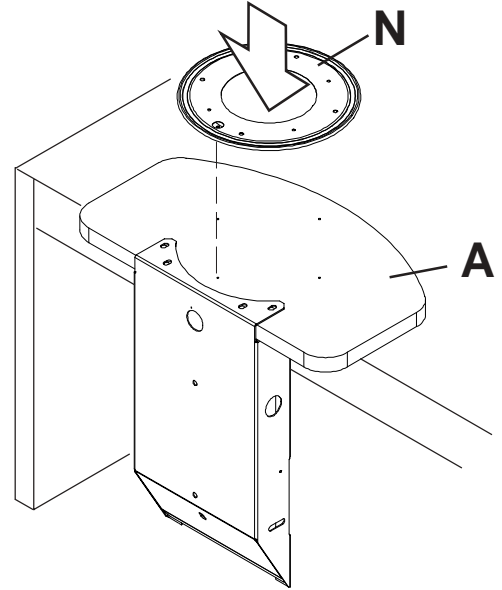

3-4 Thread one screw (O) into pilot hole in base (A) leaving screw slightly loose.

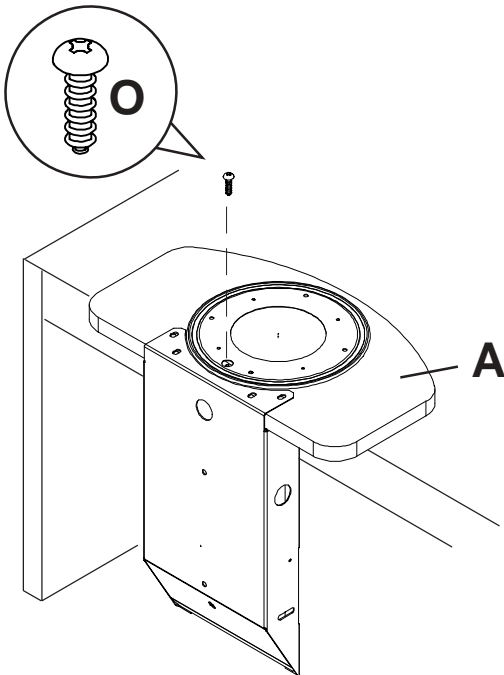

3-5 Rotate bottom of race (N) 180° and align large hole and middle hole with pilot hole. Fasten with one screw (O) leaving slightly loose. Rotate race and fasten two screws (O) at 90° intervals into remaining pilot holes, then tighten all four screws. Finally remove sticky back from adhesive felt race (L) and adhere to race (N).

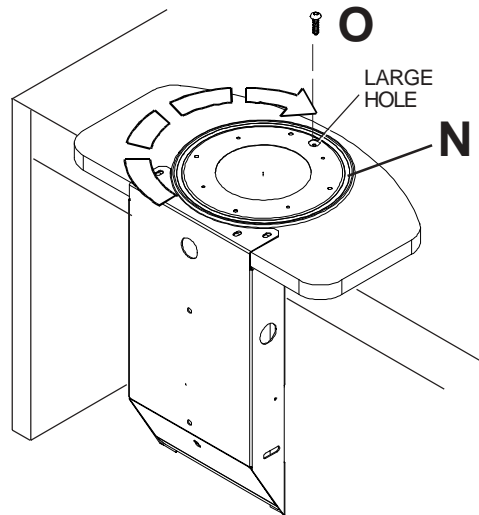

4

Note: Refer to accompanying instruction sheet to attach adapter bracket to screen.

Attach tilt plate (D) to adapter bracket (attached to screen) using four screws (T). Attach tilt bracket (E) to tilt plate (D) using two screws (J).

Notes:

- Choose holes on tilt plate according to size of screen.
- There is a 9" maximum distance between bottom of screen and tilt plate (D) shown in Side & Back View. Exceeding maximum distance may interfere with tilt.

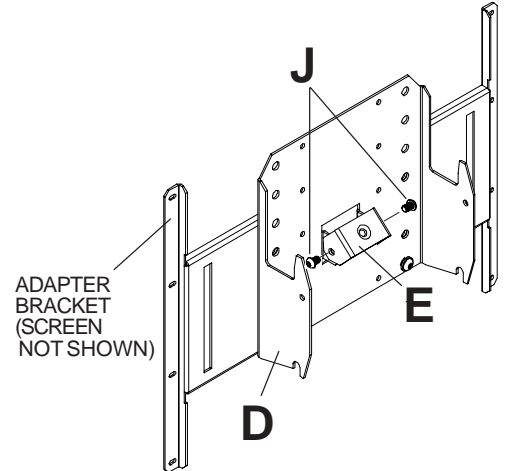
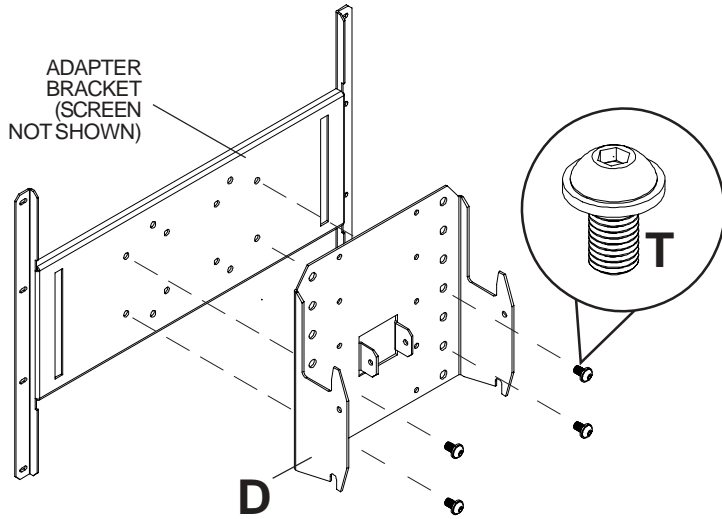

Note: Adapter bracket may appear different than illustrated.

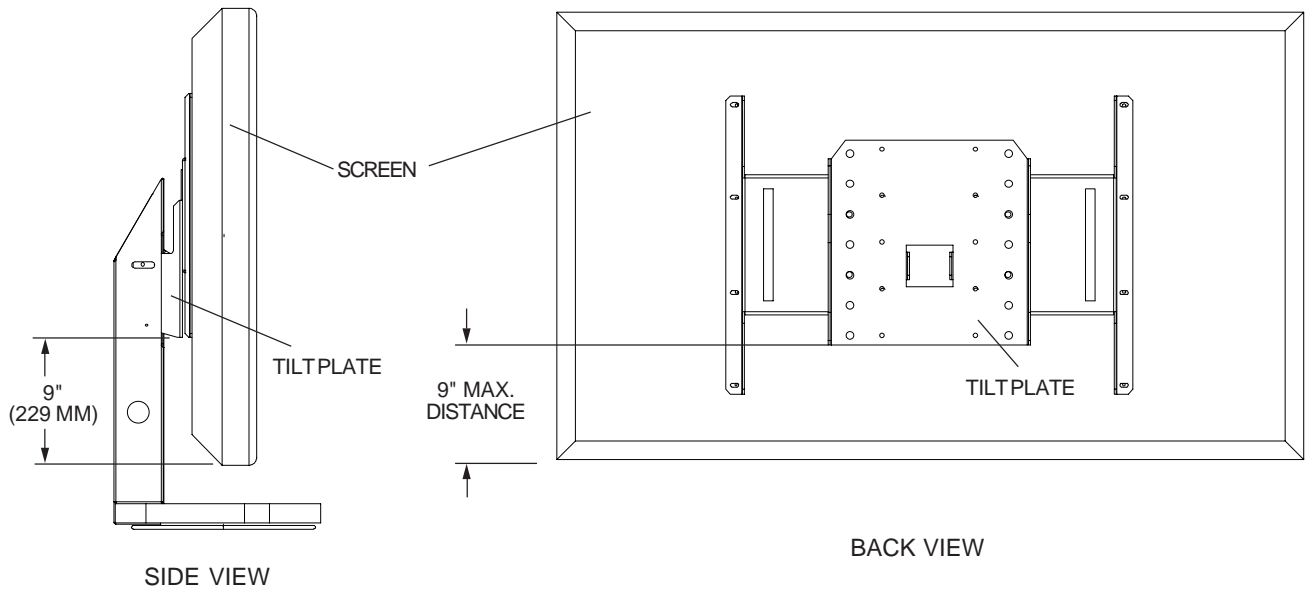

5**⚠ WARNING**

- Do not lift more weight than you can handle. Use additional man power to safely handle placement of the screen.

Attach screen/tilt plate (D) to support box (B).

- 5-1** **Note:** Two people are required for this step, one holding each end of screen.

Tilt screen back, then carefully slide tilt plate (D) into slots and lift up into support box. Level screen engaging notch in tilt plate (D) with steel rod inside support box (B).

- 5-2** Tilt plate is secure on steel rod of support box (B) when hole is visible on indicator as shown in detail 3. To ensure screen is properly placed, screen can be tilted 5° back and 10° forward. Thread knob (Q) with washer (M) into tilt bracket (E) through slot in rear of support box (B).

