

TECHNICAL DATA SHEET - **SmartMount**[®] Articulating Wall Arm for 37" to 71" flat panel screens

peerless[®]

MODELS: RTFPA63U, RTFPA63US, SA760P, SA760P-S, SA760PU, SA760PU-S



The new SmartMount[®] 700 Series Arms are more than just another pretty mount. With a full 1" of internal cable management and color-coded electrical and A/V component knock-outs, the new SA760 models provide the most cable management in the industry for a truly clean installation. Its double stud, double arm design allows for up to 7.75" of horizontal adjustment and smooth extension for perfect screen placement. The SA760 models are UL-listed for strength and reliability.

Features:

- Arm extends up to 27.8" from wall (plus thickness of adapter plate)
- SA760P includes VESA[®] 100/200x100/200/200 adapter plate and is compatible with PLP dedicated adapter plates
- Universal models accommodate 37" to 63" screens mounting holes up to 30.13" W x 17.24" H
- 1" clearance per channel for clean and simple cable management
- Dual-arm construction for extra strength and smooth motion
- Up to 7.75" total horizontal adjustment
- One-touch tilt allows adjustment of +15/-5° without the use of tools
- Three pivot points with up to 180° swivel
- Two knockouts in wall plate for optimal electrical access
- ±2.5° roll to level screen horizontally
- Allows portrait or landscape screen orientation

Accessories:

- SCS222: Double Stud Dual Component Shelf System
- SCS212: Dual Component Shelf System
- SCS221: Double Stud Component Shelf
- SCS211: Component Shelf
- ACC924/926: Cable Management Wall Channel
- ACC925: Security Fasteners
- MSA-101 (S): Center Channel Speaker Mount
- MSA-301 (S): Center and Side Speaker Mount
- ACC615: Metal Stud Toggles (for up to 125 lb flat panels)

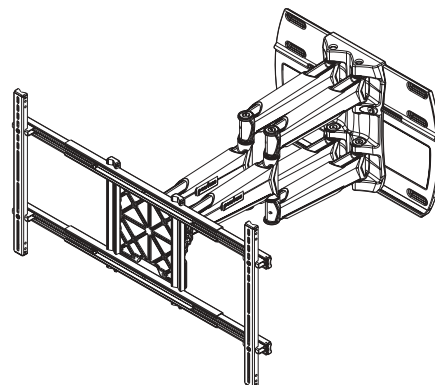
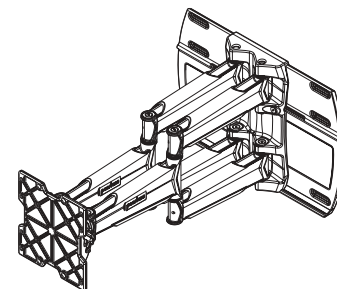

SA760P, SA760P-S

Dimensions:

Weight:

38.5 lb (17.5 kg)

Shipping weight:

45 lb (20.4 kg)

Maximum Load Capacity:

200 lb (91 kg)

Shipping Carton dimensions:

L = 29.25 in (743 mm)

W = 16 in (406 mm)

H = 7.75 in (197 mm)

SA760PU, SA760PU-S

Dimensions:

Weight:

46.6 lb (21.1 kg)

Shipping weight:

53.37 lb (24.3 kg)

Maximum Load Capacity:

200 lb (91 kg)

Shipping Carton dimensions:

L = 29.13 in (740 mm)

W = 16 in (406 mm)

H = 7.4 in (188 mm)

ARCHITECTS SPECIFICATIONS

The SmartMount[®] Articulating Wall Arm shall be Peerless models _____ and shall be located where indicated on the plans. It shall feature adjustable 15° of forward tilt and 5° backward tilt. It shall be constructed of heavy gauge cold rolled steel and finished with scratch resistant Black or Silver Fused Epoxy. Assembly and installation shall be done according to instructions provided by the manufacturer.

Peerless Industries, Inc.

3215 W. North Ave. Melrose Park, IL 60160
708-865-8870 800-865-2112 Fax 708-865-2941

www.peerlessmounts.com

ISSUED: 03-22-07 SHEET NO: 095-9702-1

© 2007, Peerless Industries, Inc. All rights reserved.

All other brand and product names are trademarks or registered trademarks of their respective owners

TECHNICAL DATA SHEET

MODELS: RTFPA63U, RTFPA63US, SA760P, SA760P-S, SA760PU, SA760PU-S

All dimensions = inch (mm)

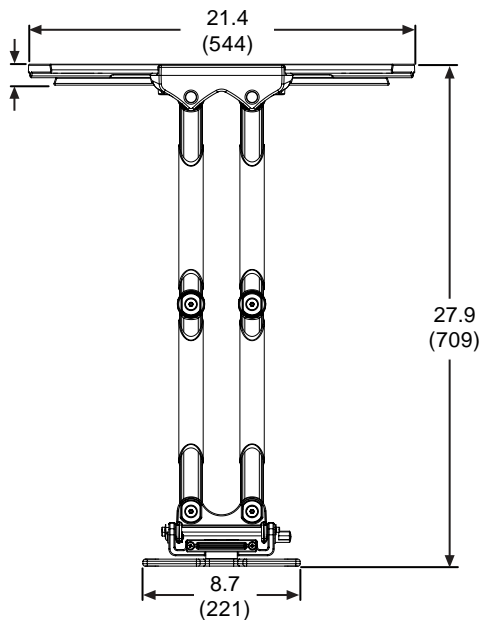

Extended Top View

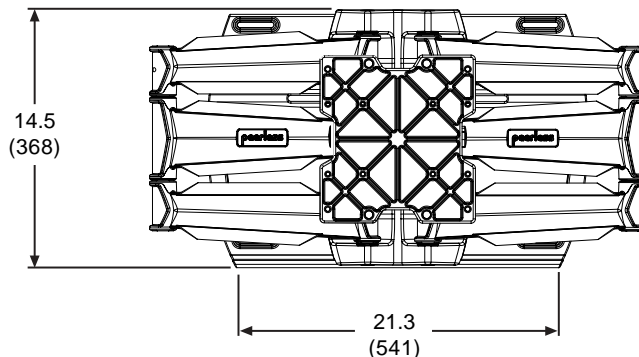

Collapsed Front View

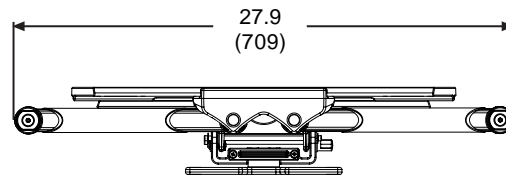

Collapsed Top View

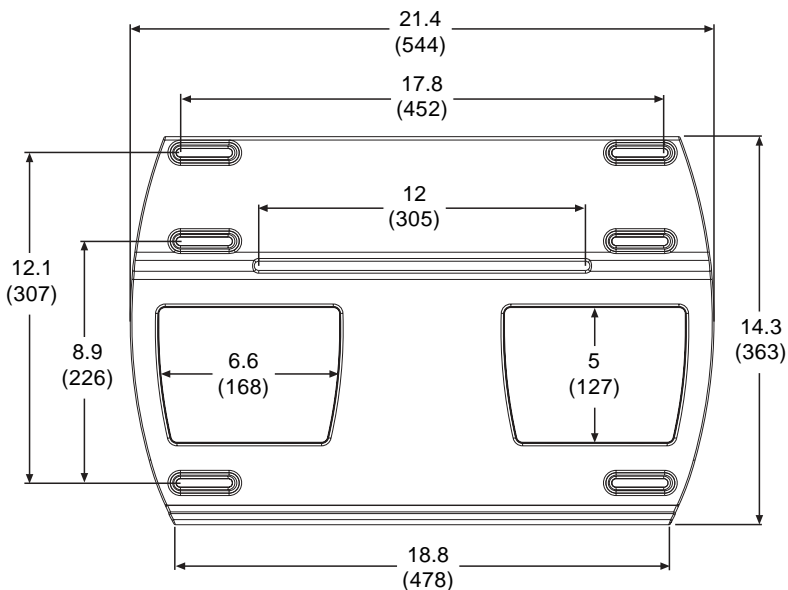

Wall Plate Detail

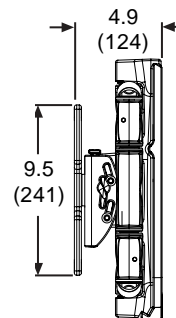

Extended Side View

MODELS: RTFPA63U, RTFPA63US, SA760P, SA760P-S, SA760PU, SA760PU-S

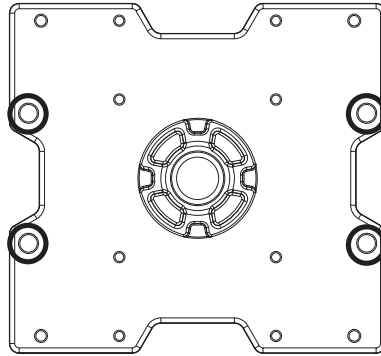

HOLE PATTERN FOR USE WITH UNIVERSAL ADAPTER BRACKET OR DEDICATED ADAPTER PLATE

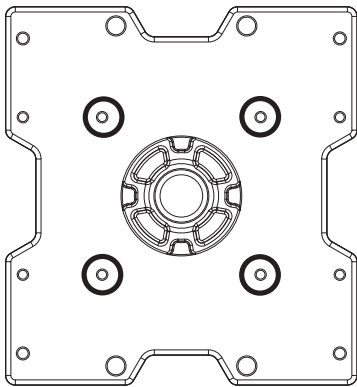

VESA® 100 x 100

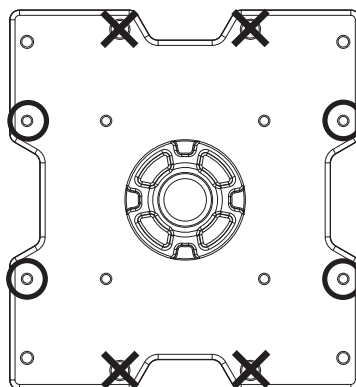

VESA® 200 x 100

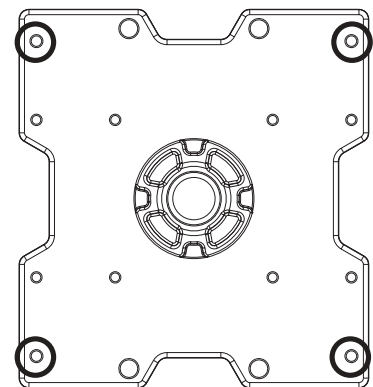

VESA® 200 x 200

Front View Adapter Plate Details

TECHNICAL DATA SHEET

MODELS: RTFPA63U, RTFPA63US, SA760P, SA760P-S, SA760PU, SA760PU-S

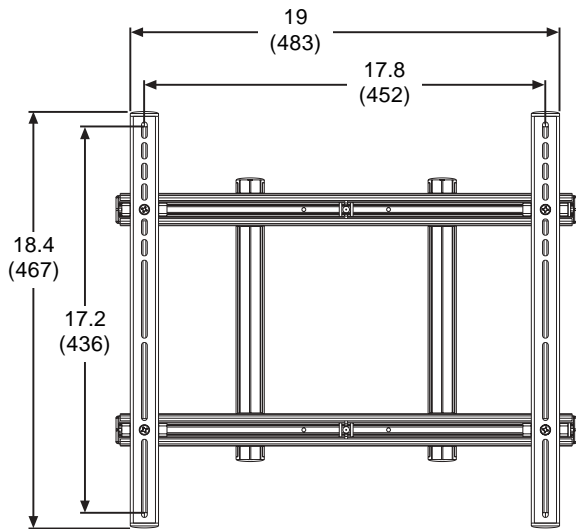

Universal Adapter Bracket Collapsed Front View

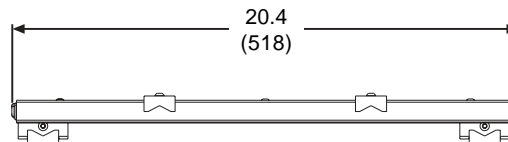

Universal Adapter Bracket Collapsed Top View

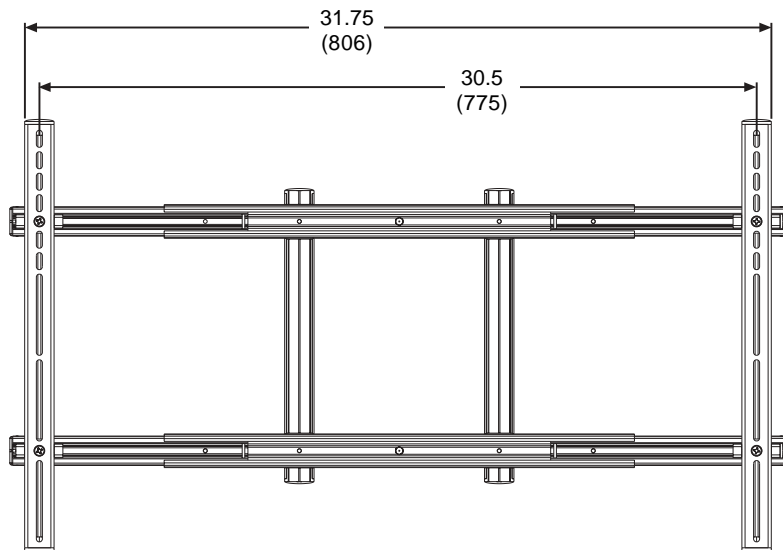

Universal Adapter Bracket Extended Front View

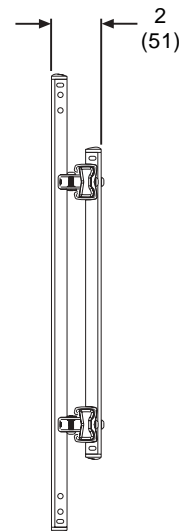

Universal Adapter Bracket Side View