



Solid Solutions - Solid Support™

Installation and Assembly:

SmartMount™

Dedicated Flat Wall Mount for Flat Panel Screens

Models: SF 16D

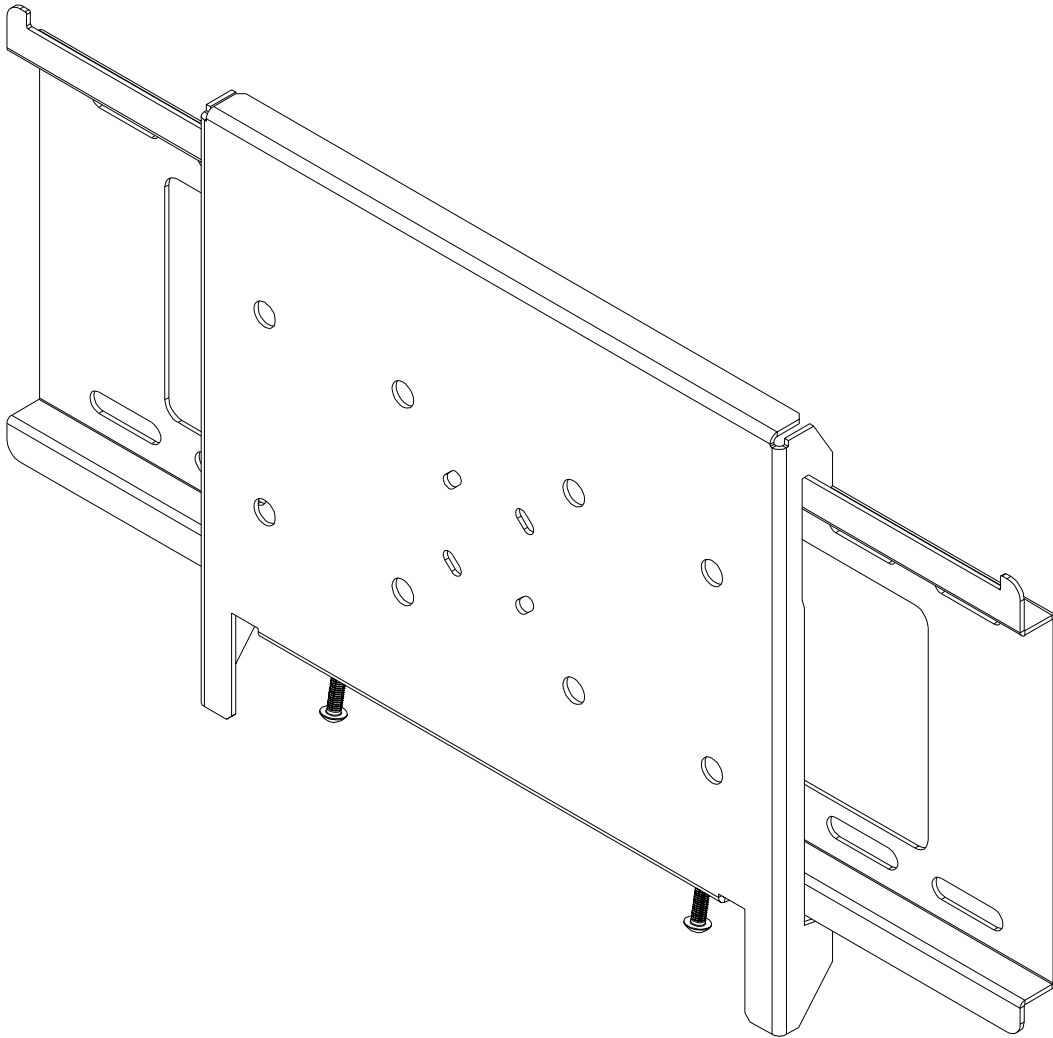

Features:

- Ultra-slim design holds the screen flat against the wall
- Integrated security features provide effective theft deterrence

Max. Load Capacity: 200 lb (90.7 kg)

Note: Read entire instruction sheet before you start installation and assembly.

WARNING

- Do not begin to install your Peerless product until you have read and understood the instructions and warnings contained in this Installation Sheet. If you have any questions regarding any of the instructions or warnings, please call Peerless customer care at 1-800-729-0307.
- This product should only be installed by a qualified professional.
- Make sure that the supporting surface will safely support the combined load of the equipment and all attached hardware and components.
- Never exceed the Maximum Load Capacity of 200 lb (90.7 kg).
- If mounting to wood wall studs, make sure that mounting screws are anchored into the center of the studs. Use of an "edge to edge" stud finder is highly recommended.
- Always use an assistant or mechanical lifting equipment to safely lift and position equipment.
- Tighten screws firmly, but do not overtighten. Overtightening can damage the items, greatly reducing their holding power.

Tools Needed for Assembly

- stud finder ("edge to edge" stud finder is recommended)
- drill
- 1/4" bit for concrete and cinder block wall
- 1/2" bit for metal stud wall
- 5/32" bit for metal or wood stud wall
- 3/8" socket wrench (socket with extended driver recommended)
- level
- 6 mm allen wrench

Accessories

- Metal Stud Fastener Kit (ACC 415)

Table of Contents

Parts List	3
Installation to Single Wood Stud Wall	4
Installation to Double Wood Stud Wall	5
Installation to Solid Concrete or Cinder Block	6
Installing Interface Bracket to PLP Adapter Plate	7
Installing Interface Bracket to LC Adapter Plate	8
Installing Flat Panel Screen to Wall Plate	9

For customer care call (800) 729-0307 or (708) 865-8870.

Parts List

Description	Qty.	Part #
AA wall plate	1	200-1797
BB interface plate	1	200-0860
CC #14 x 2.5" wood screw	4	5S1-015-C03
DD Alligator® anchor	4	590-0097
EE M10 x 1.5 x 15 mm socket head screw	4	520-9262
FF 4 mm security allen wrench	1	560-1146

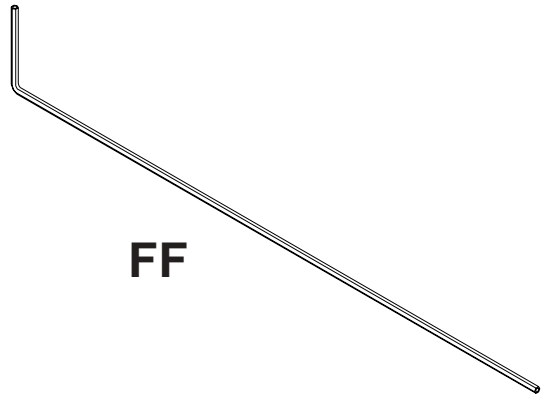
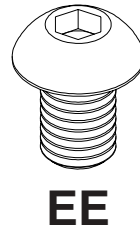
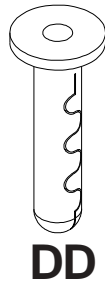
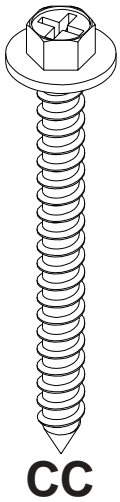
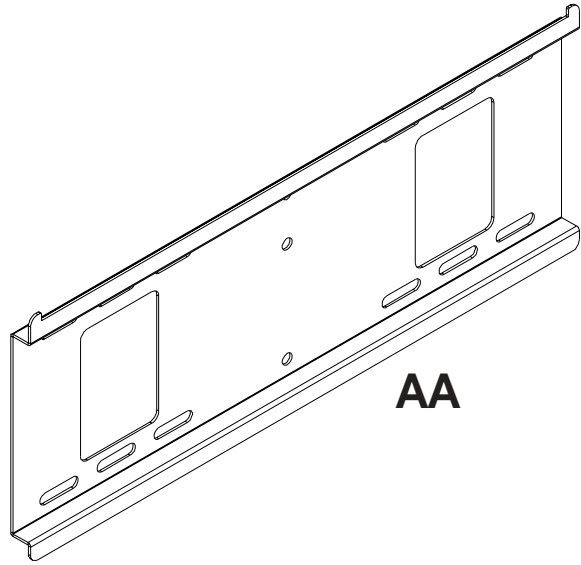
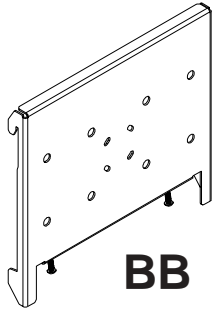

Installation to Single Wood Stud Wall

⚠ WARNING

- Installer must verify that the supporting surface will safely support the combined weight of all attached equipment and hardware.

- 1 Use a stud finder to locate the edges of the stud. Use of an edge-to-edge stud finder is highly recommended. Based on its edges, draw a vertical line down the stud's center. Place wall plate (**AA**) on wall as a template, making sure that the three mounting holes are over the stud centerline. The top mounting hole should be 2.5" above the desired screen center as shown in figure 1.1. Level plate, and mark the center of the three holes. Drill three 5/32" (4 mm) dia. holes 2-1/2" (65 mm) deep. Make sure that the wall plate is level, secure it using three #14 x 2.5" wood screws (**CC**) as shown in figure 1.2.

Skip to step 2 on page 7.

⚠ WARNING

- Tighten wood screws so that wall plate is firmly attached, but do not overtighten. Overtightening can damage the screws, greatly reducing their holding power.
- Never tighten in excess of 80 in. • lb (9 N.M.).
- Make sure that mounting screws are anchored into the center of the stud. The use of an "edge to edge" stud finder is highly recommended.
- Hardware provided is for attachment of mount through standard thickness drywall or plaster into wood studs. Installers are responsible to provide hardware for other types of mounting situations.

CS = center of screen

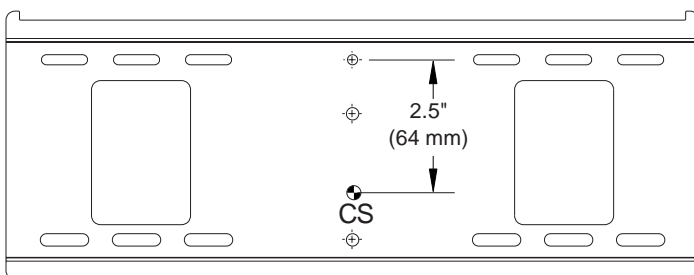

fig. 1.1

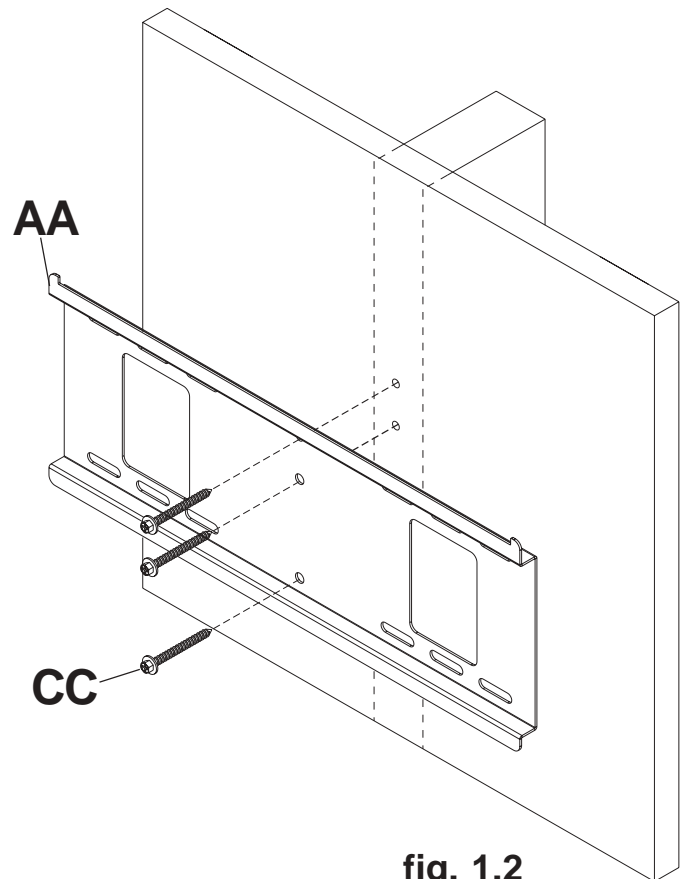

fig. 1.2

Installation to Double Wood Stud Wall

⚠ WARNING

- Installer must verify that the supporting surface will safely support the combined weight of all attached equipment and hardware.

- 1 Wall plate (**AA**) can be mounted to two studs that are 16" apart. Use a stud finder to locate the edges of the studs. Use of an edge-to-edge stud finder is highly recommended. Based on their edges, draw a vertical line down each stud's center. Place wall plate on wall as a template. The top mounting slots should be 2.5" above the desired screen center as shown in figure 1.3. Level plate, and mark the center of the four mounting holes. Make sure that the mounting holes are on the stud centerlines. Drill four 5/32" (4 mm) dia. holes 2-1/2" (65 mm) deep. Make sure that the wall plate is level, secure it using four #14 x 2.5" wood screws (**CC**) as shown in figure 1.4.

Skip to step 2 on page 7.

⚠ WARNING

- Tighten wood screws so that wall plate is firmly attached, but do not overtighten. Overtightening can damage the screws, greatly reducing their holding power.
- Never tighten in excess of 80 in. • lb (9 N.M.).
- Make sure that mounting screws are anchored into the center of the stud. The use of an "edge to edge" stud finder is highly recommended.
- Hardware provided is for attachment of mount through standard thickness drywall or plaster into wood studs. Installers are responsible to provide hardware for other types of mounting situations.

CS = center of screen

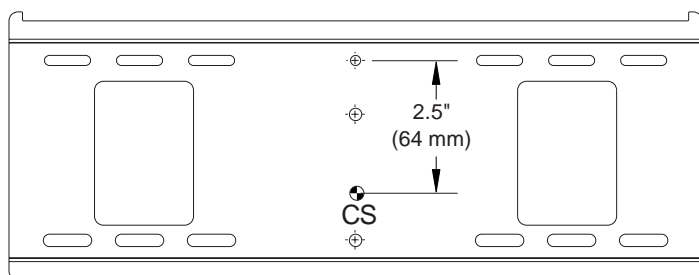

fig. 1.3

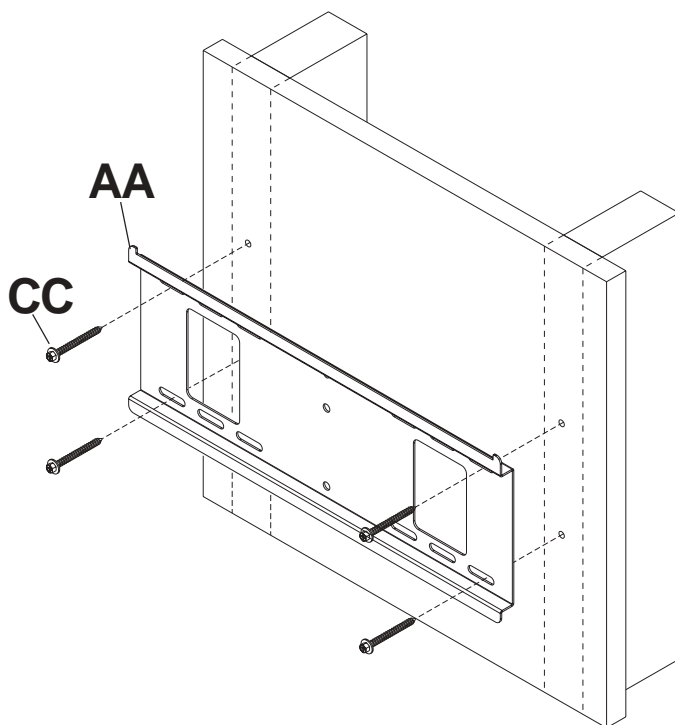

fig. 1.4

Installation to Solid Concrete or Cinder Block

⚠ WARNING

- When installing Peerless wall mounts on cinder block, verify that you have a minimum of 1-3/8" of actual concrete thickness in the hole to be used for the concrete anchors. Do not drill into mortar joints! Be sure to mount in a solid part of the block, generally 1" minimum from the side of the block. Cinder block must meet ASTM C-90 specifications. It is suggested that a standard electric drill on slow setting is used to drill the hole instead of a hammer drill to avoid breaking out the back of the hole when entering a void or cavity.
- Concrete must be 2000 psi density minimum. Lighter density concrete may not hold concrete anchor.
- Make sure that the supporting surface will safely support the combined load of the equipment and all attached hardware and components.

- 1** Make sure that wall plate (AA) is level, use it as a template to mark four mounting holes. The top mounting hole should be 2.5" above the desired screen center as shown in figure 1.1 on page 4. Drill four 1/4" (6 mm) dia. holes to a minimum depth of 2.5" (64 mm). Insert anchors (DD) in holes flush with wall as shown (right). Place wall plate over anchors and secure with #14 x 2.5" screws (CC). Level, then tighten all fasteners.

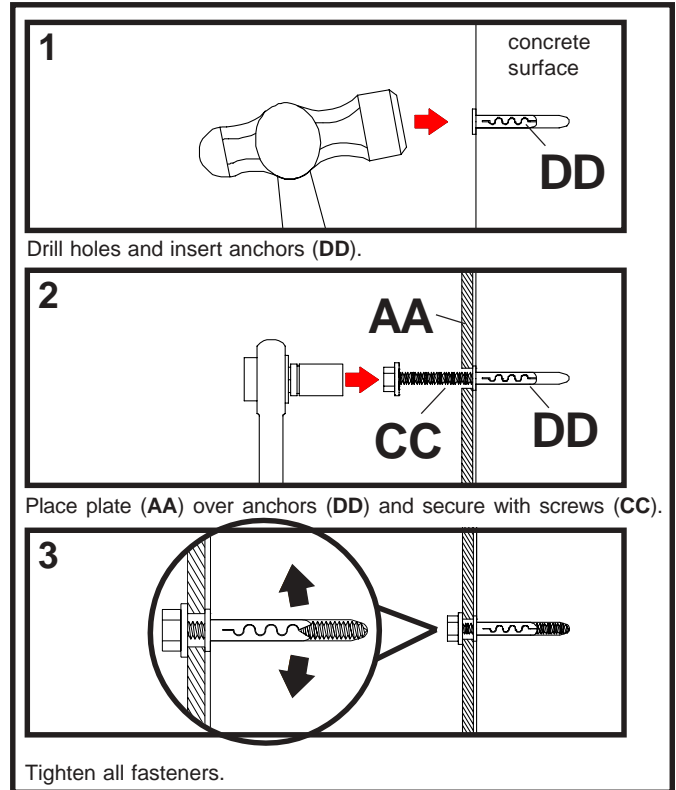

⚠ WARNING

- Tighten screws so that wall plate is firmly attached, but do not overtighten. Overtightening can damage screws, greatly reducing their holding power.
- Never tighten in excess of 80 in. • lb (9 N.M.).

⚠ WARNING

- Always attach concrete expansion anchors directly to load-bearing concrete.
- Never attach concrete expansion anchors to concrete covered with plaster, drywall, or other finishing material. If mounting to concrete surfaces covered with a finishing surface is unavoidable, the finishing surface must be counterbored as shown below. Be sure concrete anchors do not pull away from concrete when tightening screws. If plaster/drywall is thicker than 5/8", custom fasteners must be supplied by installer.

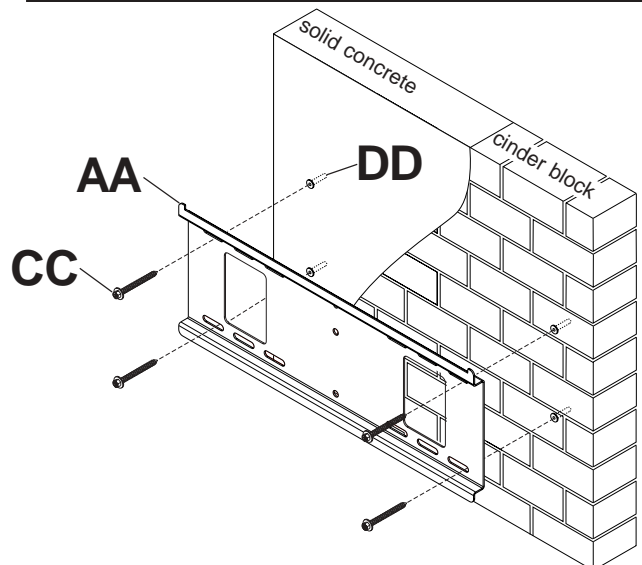
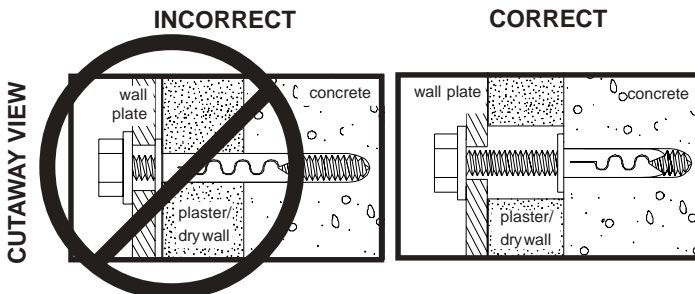

Installing Interface Bracket to PLP Adapter Plate

- 2 To prevent scratching the screen, set a cloth on a flat, level surface that will support the weight of the screen. Place screen face side down. Attach the interface bracket (**BB**) to the PLP adapter plate (sold separately) using four M10 x 15 mm socket head screws (**EE**) as shown in figures 2.1 (portrait) or 2.2 (landscape).

⚠ WARNING

- Tighten screws so adapter brackets are firmly attached. Do not tighten with excessive force. Overtightening can cause stress damage to screws, greatly reducing their holding power and possibly causing screw heads to become detached. Tighten to 40 in. • lb (4.5 N.M.) maximum torque.

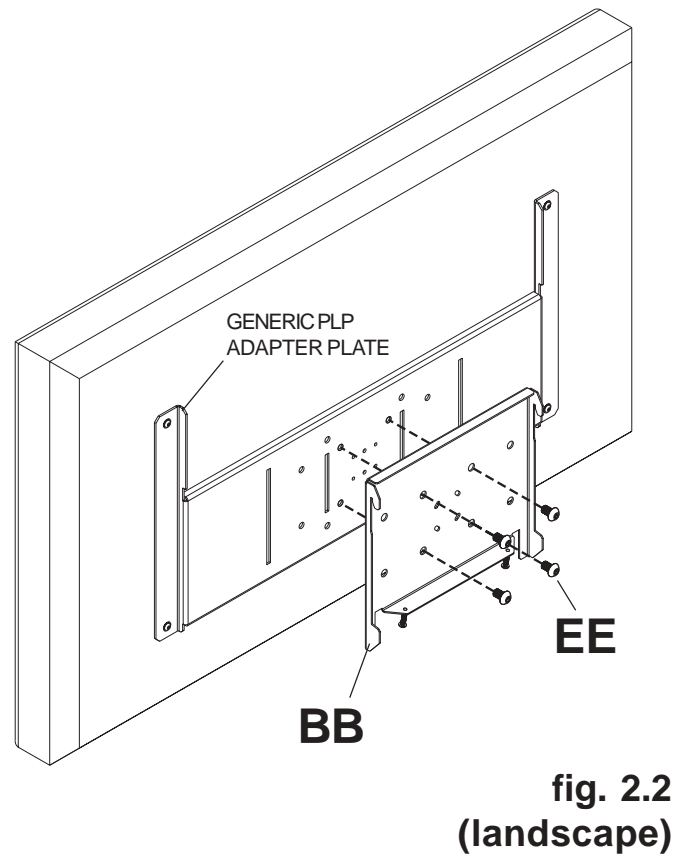
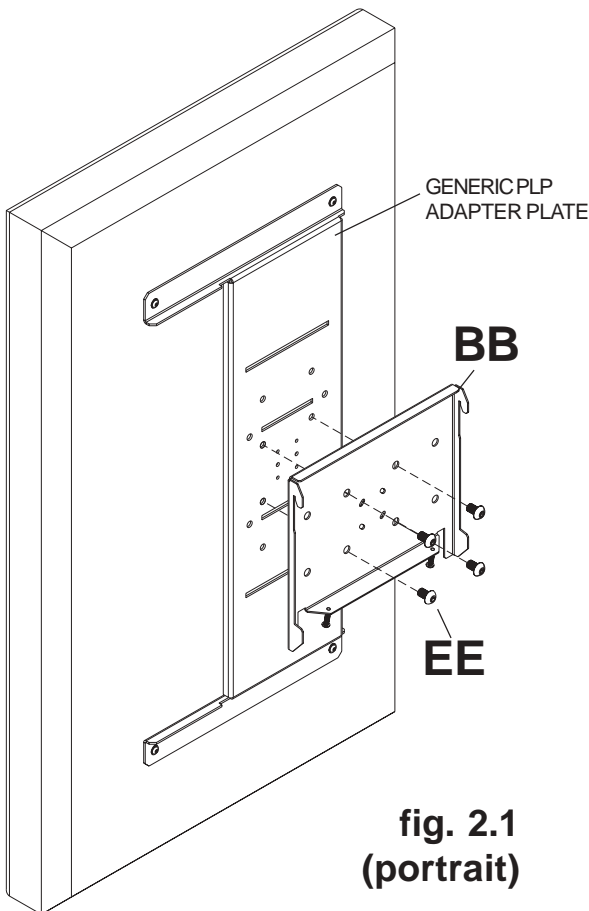

Installing Interface Bracket to LC Adapter Plate

- 2 To prevent scratching the screen, set a cloth on a flat, level surface that will support the weight of the screen. Place screen face side down. Attach the interface bracket (BB) to the LC adapter plate (sold separately) using four M5 screws provided with plate as shown in figures 2.3 (portrait) or 2.4 (landscape).

⚠ WARNING

- Tighten screws so adapter brackets are firmly attached. Do not tighten with excessive force. Overtightening can cause stress damage to screws, greatly reducing their holding power and possibly causing screw heads to become detached. Tighten to 40 in. • lb (4.5 N.M.) maximum torque.

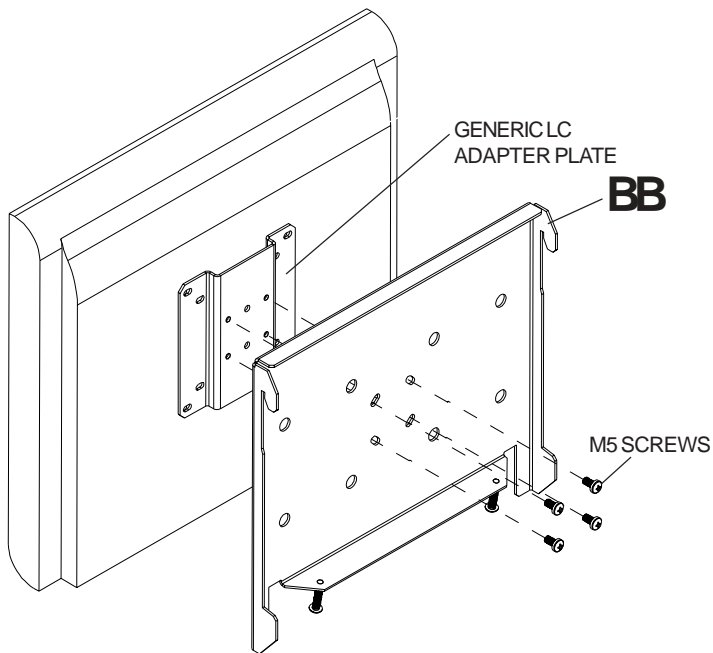

fig. 2.3
(portrait)

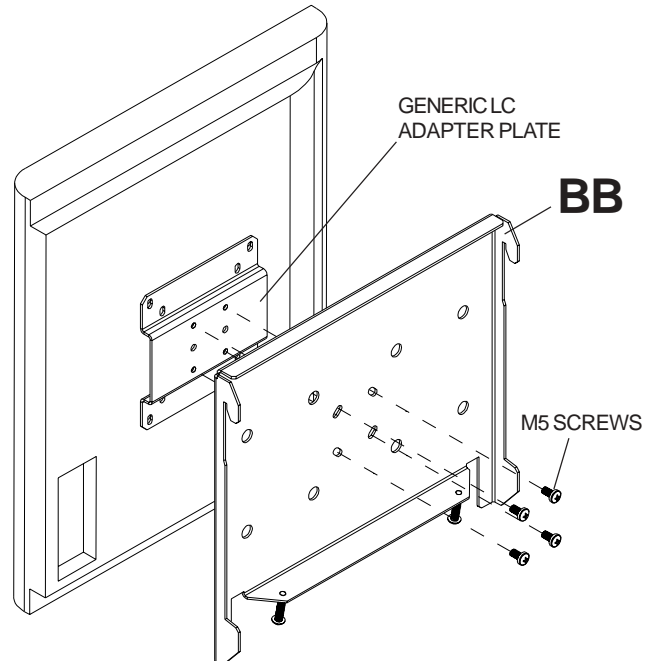

fig. 2.4
(landscape)

Mounting and Removing Flat Panel Screen

3 **Note:** Security screw may need to be loosened to avoid interference with wall plate.

Hook interface bracket (**BB**) onto wall plate (**AA**). Then slowly swing screen in as shown. Turn security screw, using security allen wrench (**FF**), clockwise at least six times to prevent screen from being removed as shown in detail 1. Screen can be adjusted horizontally if desired.

Note: To lock the screen down, tighten security screw to wall plate using security allen wrench as shown in detail 1.

To remove screen from mount, loosen security screw, swing screen away from mount, and lift screen off of mount.

⚠ WARNING

- Always use an assistant or mechanical lifting equipment to safely lift and position the plasma television.

