

## Installation and Assembly: Dedicated Flat Wall Mount for Flat Panel Screens

---

**Model:** SF 24D

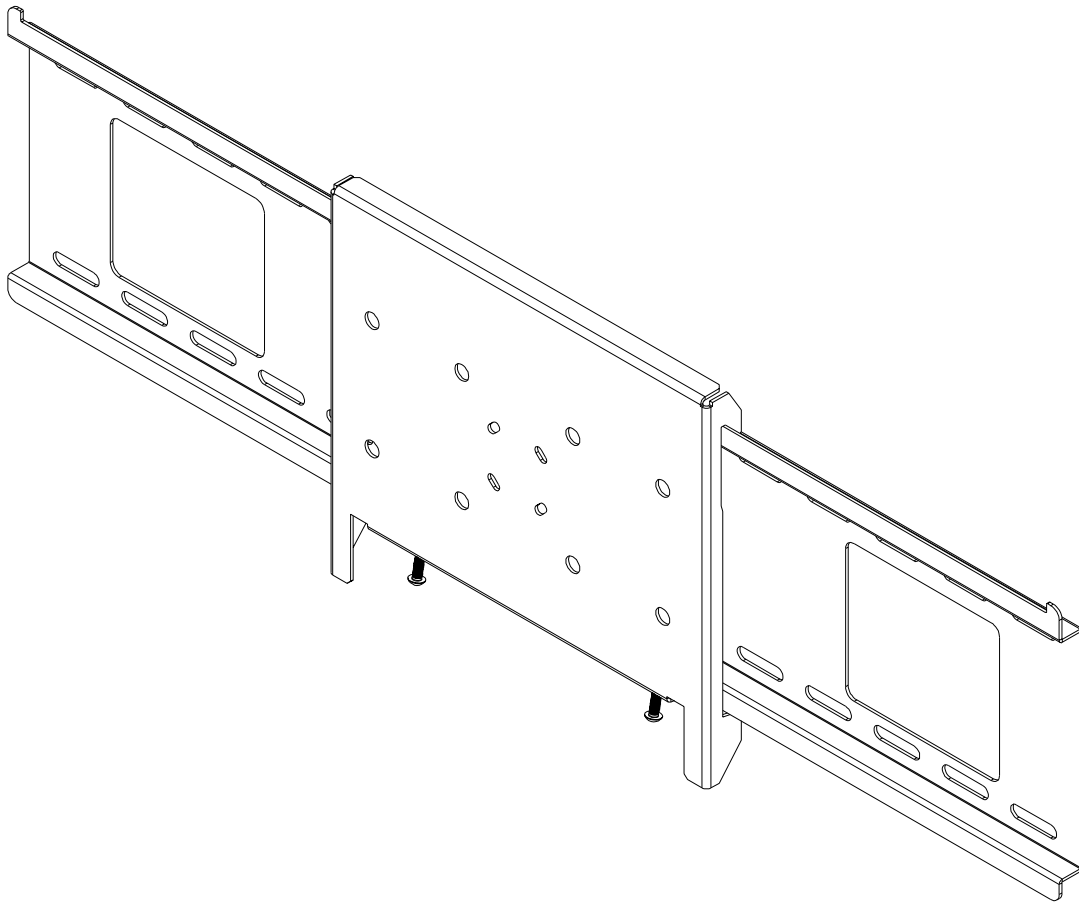

### Features:

- Ultra-slim design holds the screen flat against the wall
- Integrated security features provide effective theft deterrence

Max. Load Capacity: 200 lb (90.7 kg)

**Note:** Read entire instruction sheet before you start installation and assembly.

## **WARNING**

- Do not begin to install your Peerless product until you have read and understood the instructions and warnings contained in this Installation Sheet. If you have any questions regarding any of the instructions or warnings, please call Peerless customer care at 1-800-729-0307.
- This product should only be installed by a qualified professional.
- Make sure that the supporting surface will safely support the combined load of the equipment and all attached hardware and components.
- Never exceed the Maximum Load Capacity of 200 lb (90.7 kg).
- If mounting to wood wall studs, make sure that mounting screws are anchored into the center of the studs. Use of an "edge to edge" stud finder is highly recommended.
- Always use an assistant or mechanical lifting equipment to safely lift and position equipment.
- Tighten screws firmly, but do not overtighten. Overtightening can damage the items, greatly reducing their holding power.

### **Tools Needed for Assembly**

- stud finder ("edge to edge" stud finder is recommended)
- drill
- 1/4" bit for concrete and cinder block wall
- 1/2" bit for metal stud wall
- 5/32" bit for metal or wood stud wall
- 3/8" socket wrench (socket with extended driver recommended)
- level
- 6 mm allen wrench

### **Accessories**

- Metal Stud Fastener Kit (ACC 415)

### **Table of Contents**

Parts List .....	3
Installation to Wood Stud Wall .....	4
Installation to Solid Concrete and Cinder Block Wall .....	5
Installing Interface Bracket to PLP Adapter Plate .....	6
Installing Interface Bracket to LC Adapter Plate .....	7
Attaching Flat Panel Screen to Wall Mount .....	8

*For customer care call (800) 729-0307 or (708) 865-8870.*

# Parts List

Description	Qty	Part
AA wall plate	1	200-1796
BB interface plate	1	200-0860
CC #14 x 2.5" wood screw	4	5S1-015-C03
DD Alligator® anchor	4	590-0097
EE M10 x 1.5 x 15 mm socket head screw	4	520-9262
FF 4 mm security allen wrench	1	560-1146

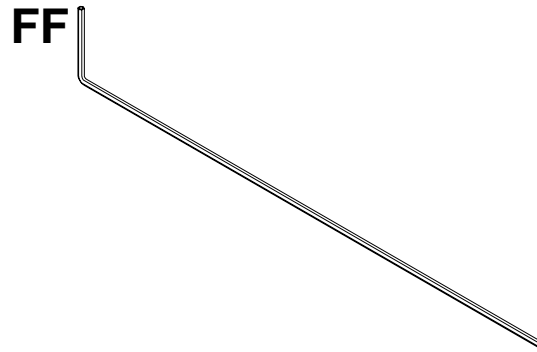
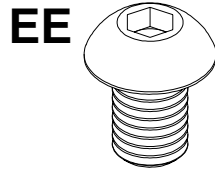
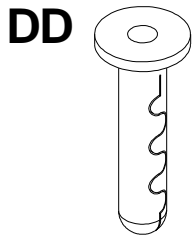
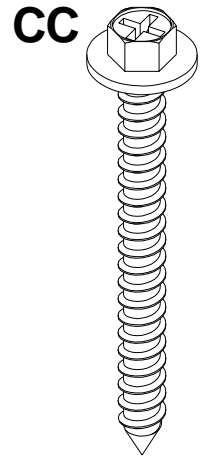
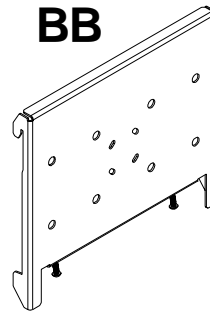
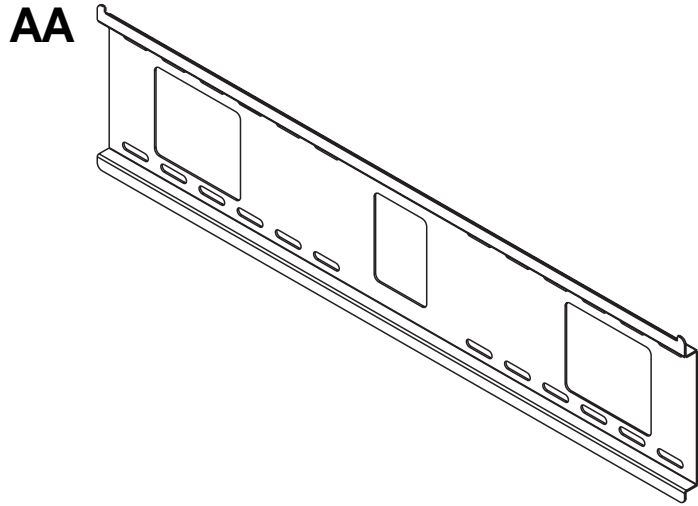

# Installation to Wood Stud Wall

## ⚠ WARNING

- Make sure that the supporting surface will safely support the combined load of the equipment and all attached hardware and components.

**1** Using a stud finder, locate the edges of the wood studs used in mounting this product. Use of an edge-to-edge stud finder is highly recommended. Based on its edges and using a level, draw a vertical line down the center of each stud. Mark a point (**point 1**) on the right stud centerline 4-5/8" above the center of screen as shown in figure 1.1. Hold wall plate (**AA**) over point 1. Using a level to ensure plate is horizontal, mark three more points (**points 2, 3, and 4**) as shown in figure 1.2.

Drill 5/32" diameter holes 2-1/2" deep through studs at the four points.

Loosely fasten wall plate (**AA**) to wall using four #14 x 2-1/2" wood screws (**CC**) as shown in figure 1.3.

**Note:** For ease of installation, start with the top right wood screw first and work counterclockwise.

Level, hold, and then tighten all screws.

*Skip to step 2 on page 6.*

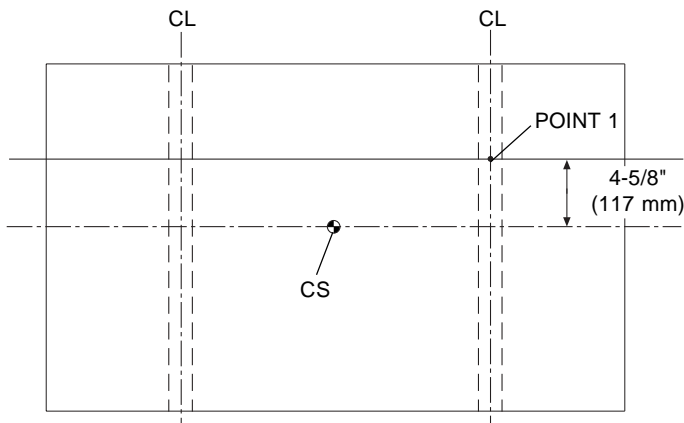

**fig 1.1**

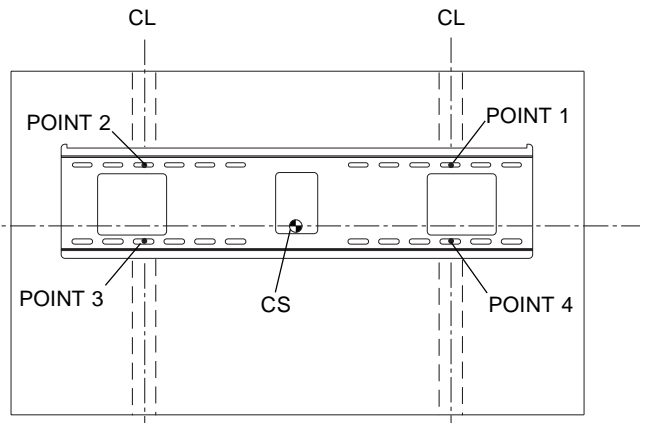
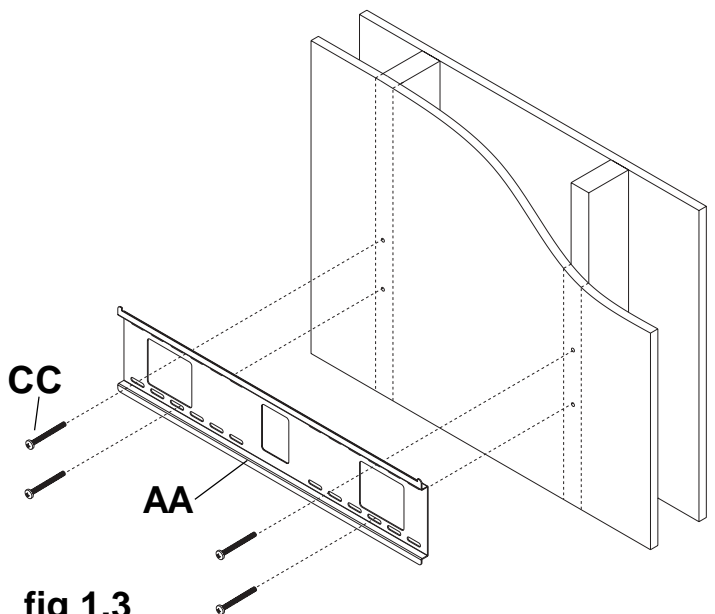

**fig 1.2**

CS = center of screen  
CL = stud centerline

## ⚠ WARNING

- Tighten wood screws so that wall plate is firmly attached, but do not overtighten. Overtightening can damage the screws, greatly reducing their holding power.
- Never tighten in excess of 80 in. • lb (9 N.M.).
- Make sure that mounting screws are anchored into the center of the stud. The use of an "edge to edge" stud finder is highly recommended.



**fig 1.3**

# Installation to Solid Concrete and Cinder Block Wall

## ⚠ WARNING

- When installing Peerless wall mounts on cinder block, verify that you have a minimum of 1-3/8" of actual concrete thickness in the hole to be used for the concrete anchors. Do not drill into mortar joints! Be sure to mount in a solid part of the block, generally 1" minimum from the side of the block. Cinder block must meet ASTM C-90 specifications. It is suggested that a standard electric drill on slow setting is used to drill the hole instead of a hammer drill to avoid breaking out the back of the hole when entering a void or cavity.
- Concrete must be 2000 psi density minimum. Lighter density concrete may not hold concrete anchor.
- Make sure that the supporting surface will safely support the combined load of the equipment and all attached hardware and components.

**1** Position wall plate (AA) on wall so that upper slots are 4-5/8" above desired center of screen. Use wall plate (AA), making sure that it is level, as a template to mark holes. Drill four 1/4" (6 mm) dia. holes to a minimum depth of 2-1/2" (64 mm). Concrete must be 2000 psi density minimum. Insert anchors (DD) in holes flush with wall as shown in figure 1.4. Place wall plate (AA) over anchors and secure with #14 x 2-1/2" (6 mm x 65 mm) wood screws (CC) as shown in figure 1.5. Make sure wall plate is level and tighten all fasteners.

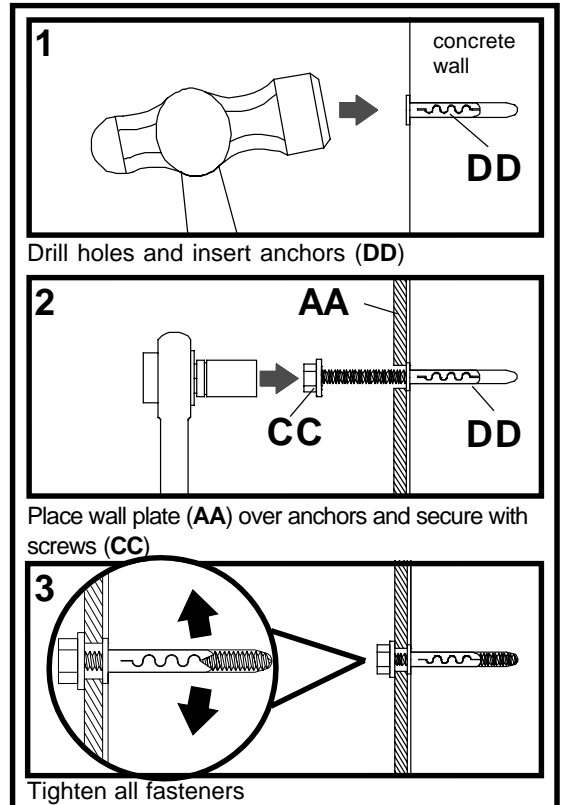

fig 1.4

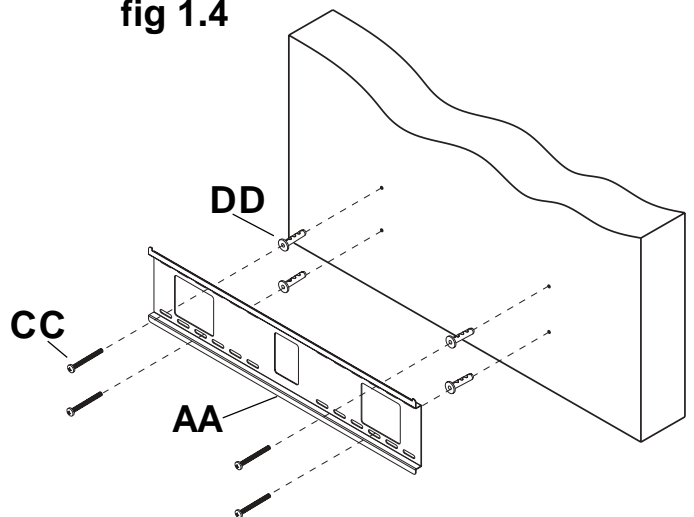

fig 1.5

## ⚠ WARNING

- Tighten wood screws firmly, but do not overtighten. Overtightening can damage the screws, greatly reducing their holding power.
- Never tighten in excess of 80 in. • lb (9 N.M.).

## ⚠ WARNING

- Concrete anchors are **not** intended for attachment to concrete wall covered with a layer of plaster, drywall, or other finishing material as shown below. If mounting to concrete wall covered with plaster/drywall is unavoidable, plaster/drywall (up to 5/8" thick) must be counterbored as shown below. Be sure concrete anchors do not pull away from concrete when tightening screws. If plaster/drywall is thicker than 5/8", custom fasteners must be supplied by installer.

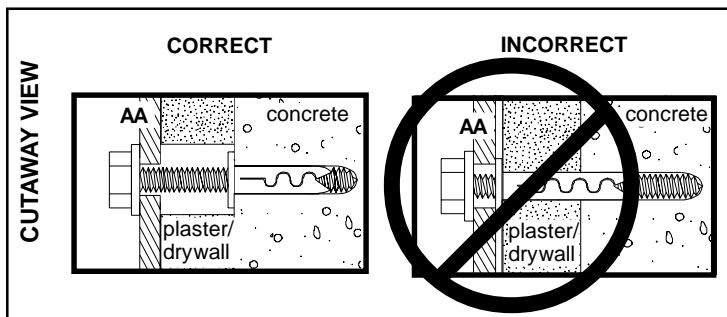

## Installing Interface Bracket

- 2** To prevent scratching the screen, set a cloth on a flat, level surface that will support the weight of the screen. Place screen face side down. Attach the interface bracket (**BB**) to the PLP adapter plate (sold separately) using four M10 x 15 mm socket head screws (**EE**) as shown in figures 2.1 (portrait) or 2.2 (landscape).

### **⚠ WARNING**

- Tighten screws so adapter brackets are firmly attached. Do not tighten with excessive force. Overtightening can cause stress damage to screws, greatly reducing their holding power and possibly causing screw heads to become detached. Tighten to 40 in. • lb (4.5 N.M.) maximum torque.

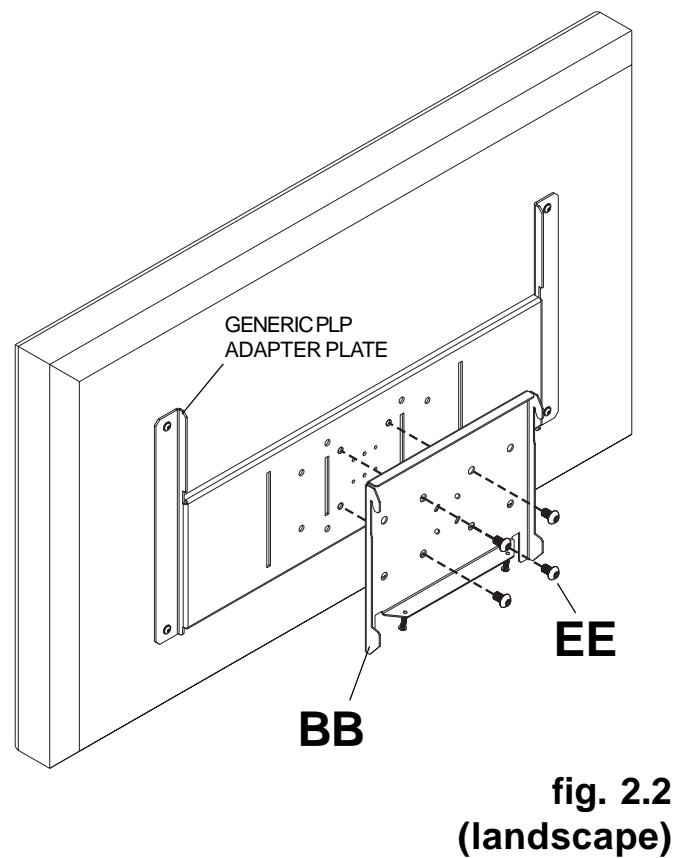
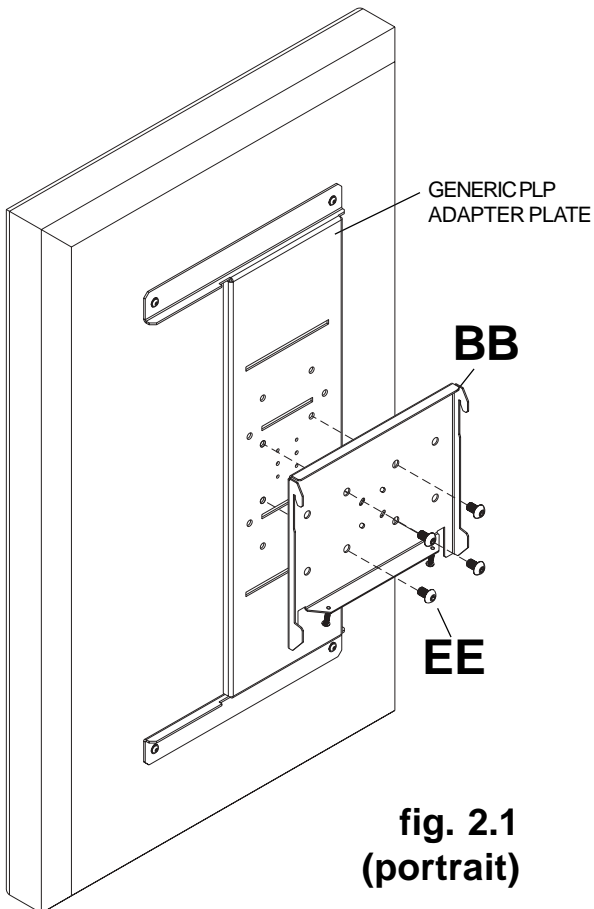

## Installing Interface Bracket to LC Adapter Plate

- 2** To prevent scratching the screen, set a cloth on a flat, level surface that will support the weight of the screen. Place screen face side down. Attach the interface bracket (**BB**) to the LC adapter plate (sold separately) using four M5 screws provided with plate as shown in figures 2.3 (portrait) or 2.4 (landscape).

### **⚠ WARNING**

- Tighten screws so adapter brackets are firmly attached. Do not tighten with excessive force. Overtightening can cause stress damage to screws, greatly reducing their holding power and possibly causing screw heads to become detached. Tighten to 40 in. • lb (4.5 N.M.) maximum torque.

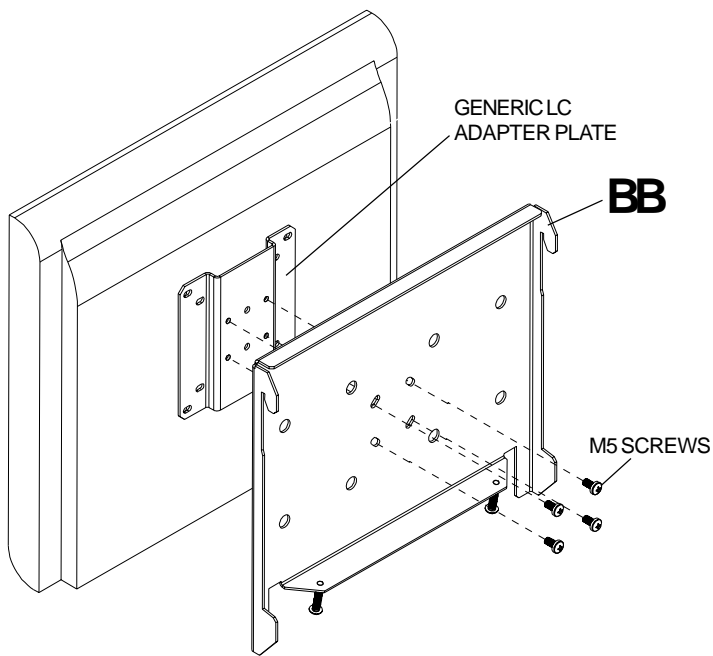

**fig. 2.3  
(portrait)**

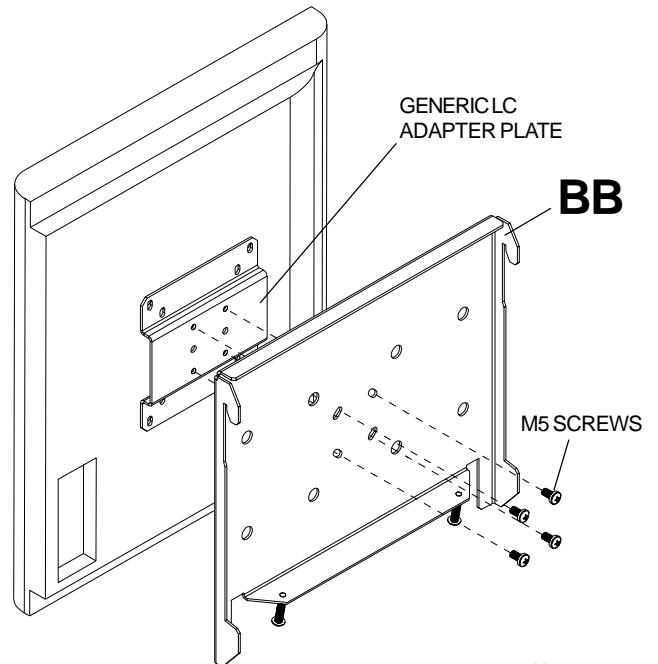

**fig. 2.4  
(landscape)**

## Mounting and Removing Flat Panel Screen

- 3** **Note:** Security screw may need to be loosened to avoid interference with wall plate.
- Hook interface bracket (**BB**) onto wall plate (**AA**). Then slowly swing screen in as shown. Turn security screw, using security allen wrench (**FF**), clockwise at least six times to prevent screen from being removed as shown in detail 1. Screen can be adjusted horizontally if desired.

**Note:** To lock the screen down, tighten security screw to wall plate using security allen wrench as shown in detail 1.

To remove screen from mount, loosen security screw, swing screen away from mount, and lift screen off of mount.

### **⚠ WARNING**

- Always use an assistant or mechanical lifting equipment to safely lift and position the plasma television.

