

TECHNICAL DATA SHEET - Flat Panel Pull-out Swivel Wall Mount With Universal Adapter Bracket



MODELS: SP850-UNL, SP850-UNLP, SP850-UNL-S,
SP850-UNLP-S, SP850-UNLP-GB, SP850-UNLP-GS

The 2" ultra-thin design keeps the screen close to the wall and enables the profile of the mount to look like a component of the screen. With a boxed-in wall plate that eliminates the view of the mount hardware from a side view, the pull-out swivel mount is the perfect installation product for in room hospitality, public and digital signage, POS stations and office applications. Featuring up to +/- 45° of swivel depending on the screen size and up to 10" of pull out, the pull-out swivel mount provides a user with many viewing angles. Installation and screen mounting are enhanced with the LockKey™ installation brace. Designed to mount on 16" wood studs, the wall plate accommodates up to 4" of horizontal shift. Offers unparalleled compatibility with medium to large sized plasma and LCD flat panel screens 26" to 50". Includes all necessary screen attachment hardware and both shallow and deep brackets to attach to screens with a bump-out on the back.

Features:

- For virtually any 26" to 50" screen (150 lbs max)
- Easy pull-out swivel provides quick maintenance access
- Built in adapter plate supports VESA 100 and 200 x 100 compatibility
- Works with Peerless dedicated and universal PLP adapter plates
- Ideal for wall mount applications and attachment to false backslashes
- 3.4" deep when closed, swivel arms extend to 11.8"
- When extended, screen can swivel up to 45° left and right depending on screen size
- Screen can tilt 5° or 10° forward
- Roll can be adjusted 1° clockwise or counterclockwise
- Mounts on 16" studs
- Clean profile design hides wiring and mount within enclosed wall plate
- Includes security screws for attachment at the screen (SP850-UNLP, SP850-UNLP-S, SP850-UNLP-GB, SP850-UNLP-GS)
- Includes security lock out screw to eliminate pull out ability
- LockKey™ installation brace included
- Available in black or silver

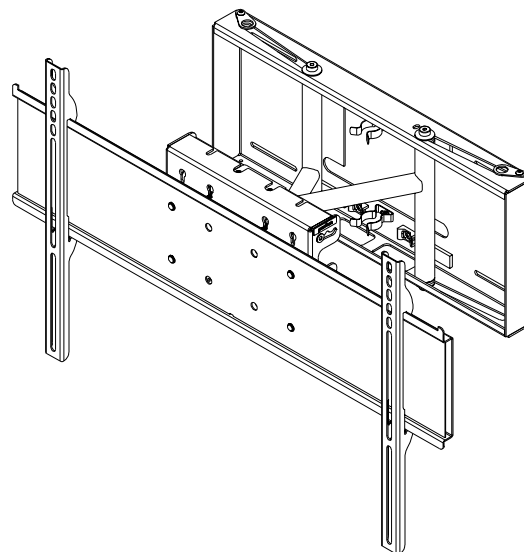

Dimensions:

Weight:
31.5 lb (14.3 kg)

Shipping weight:
39 lb (17.69 kg)

Maximum Load Capacity:
150 lb (68 kg)

Shipping Carton dimensions:
L= 32 in (813 mm)
W= 9.75 in (248 mm)
H= 12 in (305 mm)

ARCHITECTS SPECIFICATIONS

The Flat Panel Pull-out Swivel Wall Mount with Universal Adapter Bracket shall be a Peerless model _____ and shall be located where indicated on the plans. It shall be constructed of heavy gauge steel. It shall feature up to 45° of swivel left and right depending on screen size. It shall feature 5° or 10° of forward tilt. It shall feature +/- 1° of roll. The finish shall be scratch resistant black or silver fused epoxy. Assembly and installation shall be done according to instructions provided by the manufacturer.

TECHNICAL DATA SHEET

MODELS: SP850-UNL, SP850-UNLP, SP850-UNL-S, SP850-UNLP-S, SP850-UNLP-GB, SP850-UNLP-GS

ALL DIMENSION = INCH
(MM)

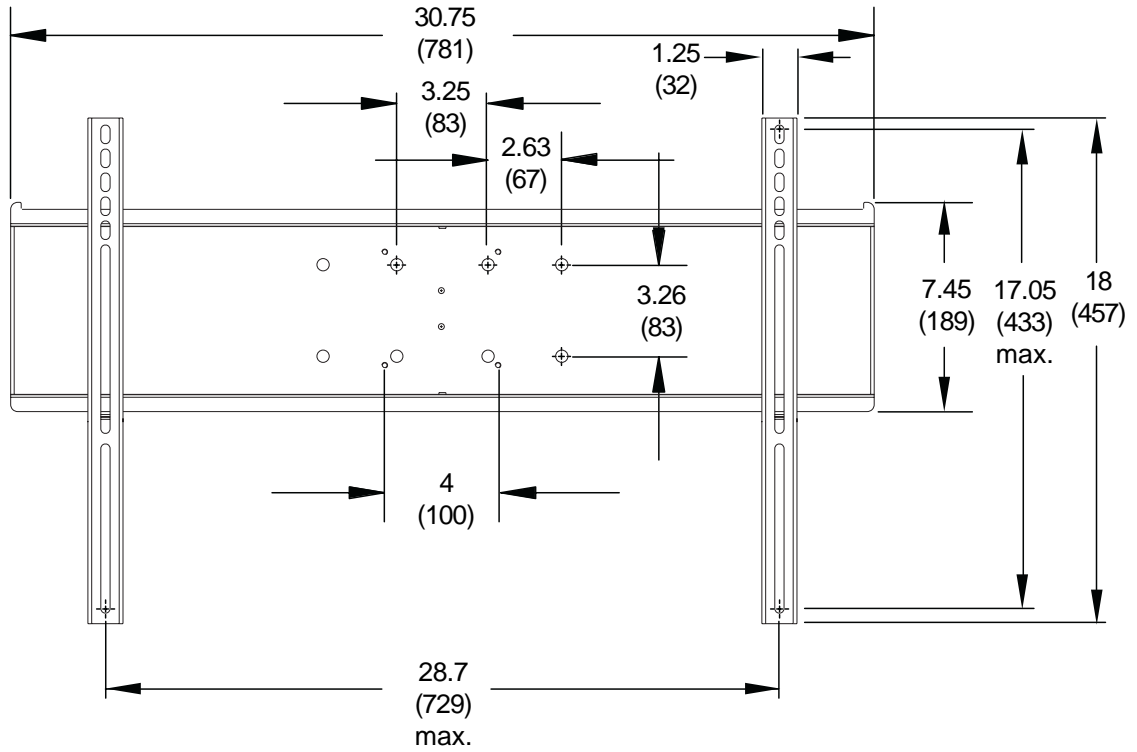

ADAPTER PLATE DETAIL

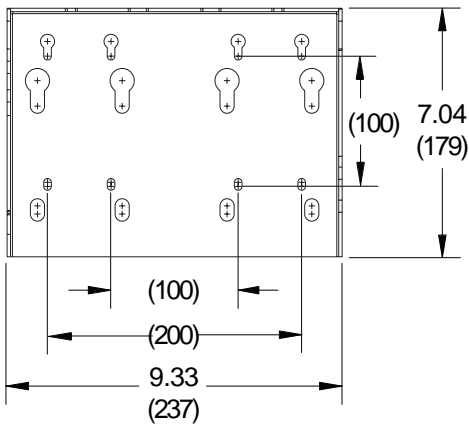

BRACKET DETAIL

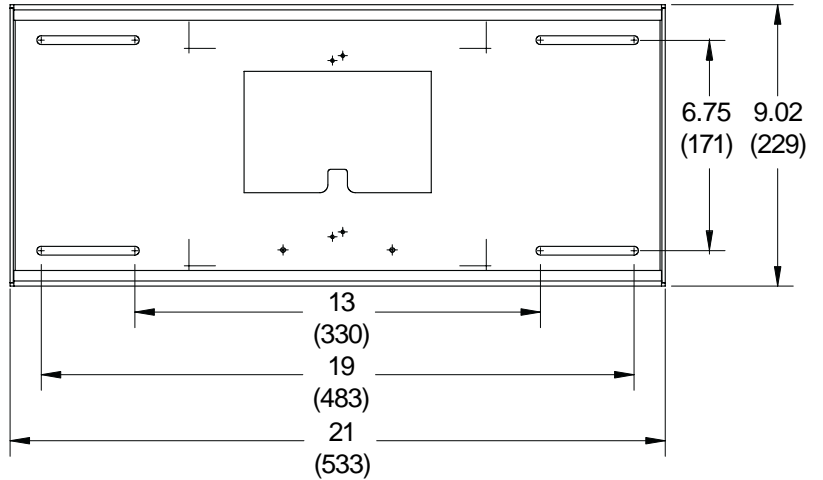

WALL BRACKET DETAIL

TECHNICAL DATA SHEET

MODELS: SP850-UNL, SP850-UNLP, SP850-UNL-S, SP850-UNLP-S, SP850-UNLP-GB, SP850-UNLP-GS

ALL DIMENSION = INCH (MM)

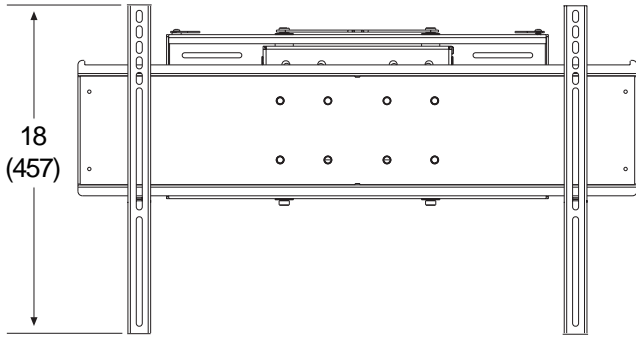

FRONT VIEW

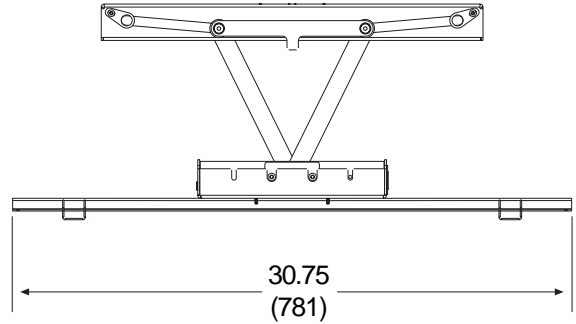

TOP VIEW

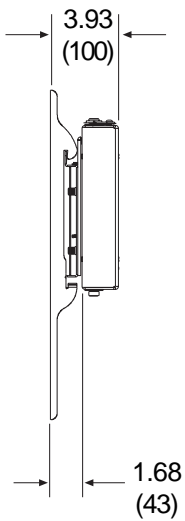

SIDE VIEW WITH DEEP BRACKET (collapsed)

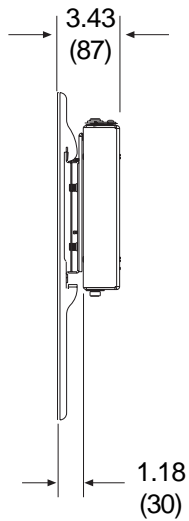

SIDE VIEW WITH SHALLOW BRACKET (collapsed)

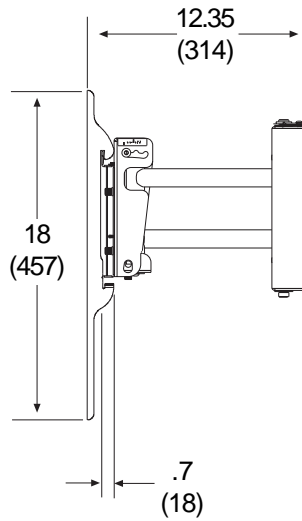

SIDE VIEW WITH DEEP BRACKET (extended)

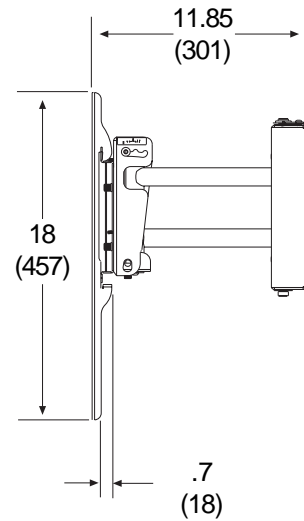

SIDE VIEW WITH SHALLOW BRACKET (extended)

TECHNICAL DATA SHEET

MODELS: SP850-UNL, SP850-UNLP, SP850-UNL-S, SP850-UNLP-S, SP850-UNLP-GB, SP850-UNLP-GS

ALL DIMENSION = INCH
(MM)

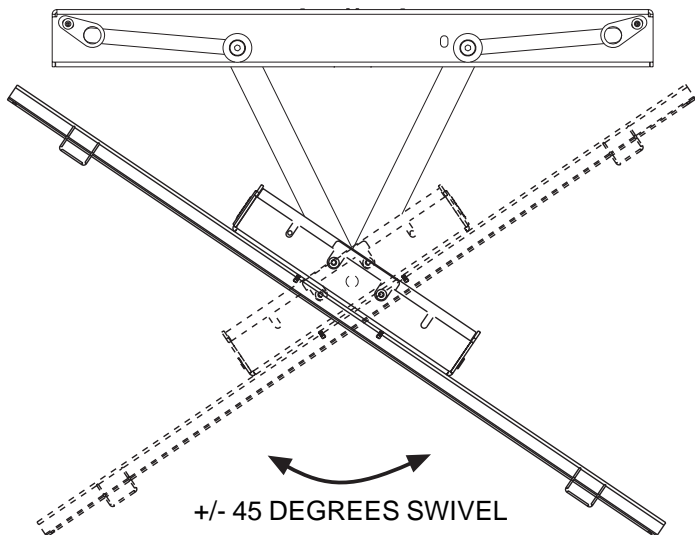

TOP VIEW

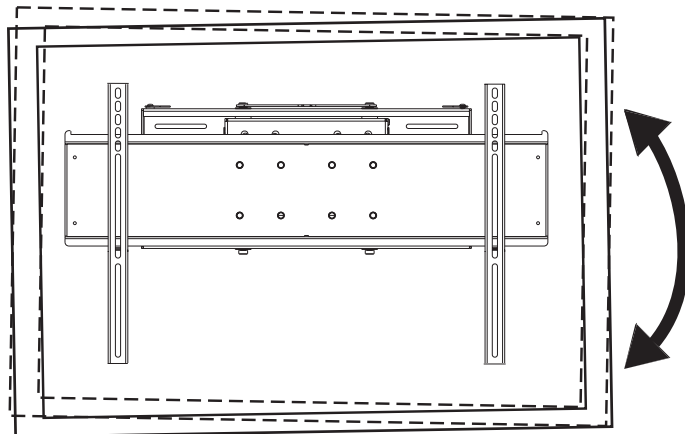

+/- 1 DEGREE ROLL

FRONT VIEW

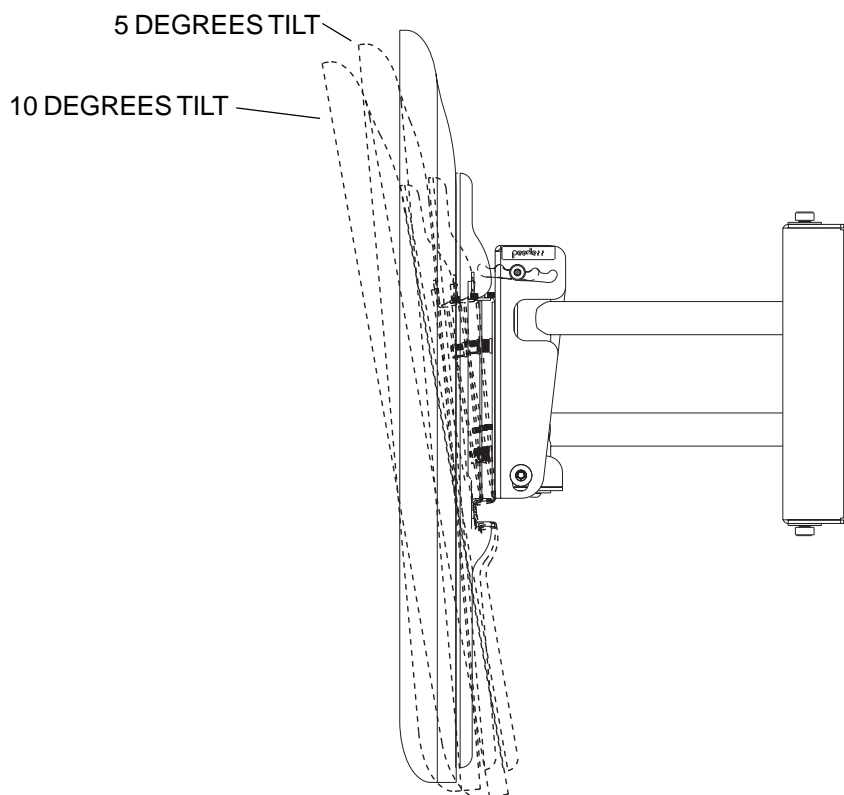

SIDE VIEW